

SRAM

SRAM[®]

technical manual
gear hub systems

(english)

SRAM® LLC WARRANTY

EXTENT OF LIMITED WARRANTY

SRAM warrants its products to be free from defects in materials or workmanship for a period of two years after original purchase. This warranty only applies to the original owner and is not transferable. Claims under this warranty must be made through the retailer where the bicycle or the SRAM component was purchased. Original proof of purchase is required.

LOCAL LAW

This warranty statement gives the customer specific legal rights. The customer may also have other rights which vary from state to state (USA), from province to province (Canada), and from country to country elsewhere in the world.

To the extent that this warranty statement is inconsistent with the local law, this warranty shall be deemed modified to be consistent with such law, under such local law, certain disclaimers and limitations of this warranty statement may apply to the customer. For example, some states in the United States of America, as well as some governments outside of the United States (including provinces in Canada) may:

- a. Preclude the disclaimers and limitations of this warranty statement from limiting the statutory rights of the consumer (e.g. United Kingdom).
- b. Otherwise restrict the ability of a manufacturer to enforce such disclaimers or limitations.

LIMITATIONS OF LIABILITY

To the extent allowed by local law, except for the obligations specifically set forth in this warranty statement, in no event shall SRAM or its third party suppliers be liable for direct, indirect, special, incidental, or consequential damages.

LIMITATIONS OF WARRANTY

This warranty does not apply to products that have been incorrectly installed and/or adjusted according to the respective SRAM technical installation manual. The SRAM installation manuals can be found online at www.sram.com, www.RockShox.com, or www.avidbike.com.

This warranty does not apply to damage to the product caused by a crash, impact, abuse of the product, non-compliance with manufacturers specifications of usage or any other circumstances in which the product has been subjected to forces or loads beyond its design.

This warranty does not apply when the product has been modified.

This warranty does not apply when the serial number or production code has been deliberately altered, defaced or removed.

This warranty does not apply to normal wear and tear. Wear and tear parts are subject to damage as a result of normal use, failure to service according to SRAM recommendations and/or riding or installation in conditions or applications other than recommended.

Wear and tear parts are identified as:

- Dust seals
- Bushings
- Air sealing o-rings
- Glide rings
- Rubber moving parts
- Foam rings
- Rear shock mounting hardware and main seals
- Upper tubes (stanchions)
- Stripped threads/bolts (aluminium, titanium, magnesium or steel)
- Brake sleeves
- Brake pads
- Chains
- Sprockets
- Cassettes
- Shifter and brake cables (inner and outer)
- Handlebar grips
- Shifter grips
- Jockey wheels
- Disc brake rotors
- Wheel braking surfaces
- Bottomout pads
- Bearings
- Bearing races
- Pawls
- Transmission gears
- Tools

This warranty shall not cover damages caused by the use of parts of different manufacturers.

This warranty shall not cover damages caused by the use of parts that are not compatible, suitable and/or authorised by SRAM for use with SRAM components.

This warranty shall not cover damages resulting from commercial (rental) use.

Copyright © SRAM 2009, LLC

Publ. No. GEN.000000002022 · Rev. A

Released June 2009

For exploded diagram and part number information, please refer to the Spare Parts Catalog available on our web site at www.sram.com.

For order information, please contact your local SRAM distributor or dealer.

Information contained in this publication is subject to change at any time without prior notice. For the latest technical information, please visit our website at www.sram.com.









Your product's appearance may differ from the pictures/diagrams contained in this catalog.

This publication includes trademarks and registered trademarks of SRAM Corporation designated by the symbols ™ and ®, respectively.





Product names used in this document may be trademarks or registered trademarks of others.



GEAR HUBS AND SHIFTERS

	i-MOTION® 9	5
	i-MOTION® 3	27
	SRAM® Torpedo® Singlespeed	49
	DualDrive™	58
	SRAM® S7	69
	SRAM® P5	77
	SRAM® P5 Cargo	85
	SRAM® T3	92
	Sparc®	101

GEAR HUB SYSTEM COMPONENTS

	Brake Lever	108
	i-LIGHT™ – Dynamo Hubs	110
	Power Chain™	114
	SRAM Komfy™ – Hydraulic Disc Brake See Technical Manual AVID – „Juicy® 5“	

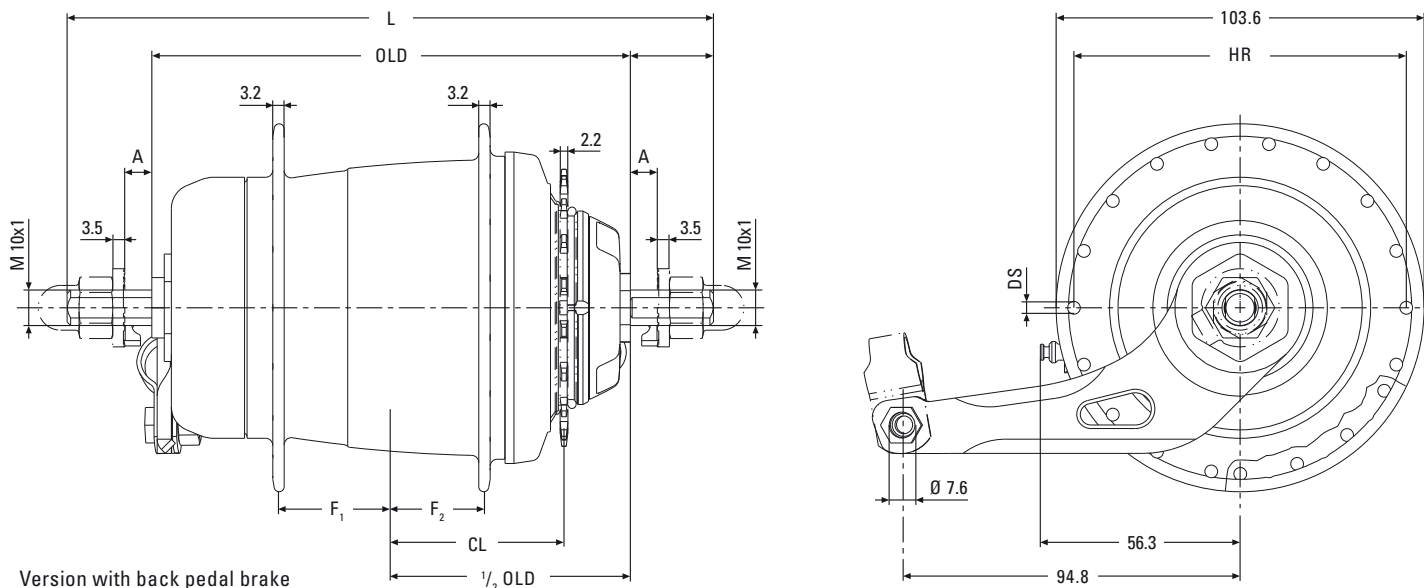

Version with back pedal brake

GETRIEBENABEN

		i-MOTION 9 with back pedal brake	i-MOTION 9 disc brake compatib.	i-MOTION 9 without brake
	Speeds	9	9a	9
	Brake	With back pedal brake	Adaptor for disc brake	without
Over Locknut Dim., OLD		135 mm	135 mm	135 mm
Achse	Length, L	186 mm	186 mm	186 mm
	Ends Diameter	M 10x1	M 10x1	M 10x1
Dropout Width Dim., A		min. 4 mm / max. 10 mm	min. 4 mm / max. 10 mm	min. 4 mm / max. 10 mm
Speichen	Holes	36 or 32	36 or 32	36 or 32
	Hole Diameter, DS	2.8 mm	2.8 mm	2.8 mm
	Hole Ref. Ø, HR	93.6 mm	93.6 mm	93.6 mm
	Flange Dist. to 1/2 OLD	F ₁ = 26.5 mm / F ₂ = 31.5 mm	F ₁ = 26.5 mm / F ₂ = 31.5 mm	F ₁ = 26.5 mm / F ₂ = 31.5 mm
Übersetzung	Overall	340 %	Gangsprung ←	←
	1st gear	0,542	↓	←
	2nd gear	0,621	14 %	←
	3rd gear	0,727	17 %	←
	4th gear	0,853	17 %	←
	5th gear	1,000	17 %	←
	6th gear	1,172	17 %	←
	7th gear	1,375	17 %	←
	8th gear	1,611	17 %	←
	9th gear	1,844	14 %	←
Kette	Chainline, CL	48.8 mm	48.8 mm	48.8 mm
	Ratio	1.73 – 1.90	min. 1.73	min. 1.73
Dimensions		1/2" x 1/8" and 1/2" x 3/32"	1/2" x 1/8" and 1/2" x 3/32"	1/2" x 1/8" and 1/2" x 3/32"
Sprocket		18 / 19 / 20 / 21 / 22 teeth	18 / 19 / 20 / 21 / 22 teeth	18 / 19 / 20 / 21 / 22 teeth
Shifter		i-MOTION 9 IBS SL and i-MOTION 9 SL	←	←
Disc Brake		—	6 holes	—
Hand brake lever		—	Disc brake compatible	—
Tandem		Not suitable for tandems, transport bicycles or similar		←
Weight		2,400 g	1,960 g	1,960 g
Finish	Mat. Hub shell	Aluminum	Aluminum	Aluminum
	Surface	Satin matt "Lux" anodized	Satin matt "Lux" anodized	Satin matt "Lux" anodized

i-MOTION® 9

TECHNICAL DATA / ASSEMBLY REQUIREMENTS

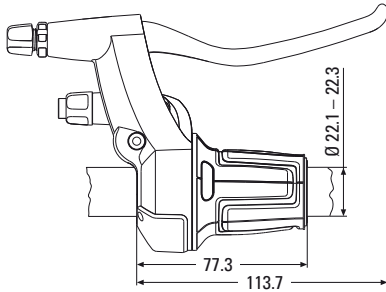

Shifter i-MOTION 9 IBS SL

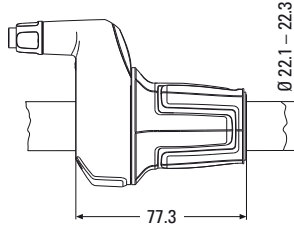

Shifter i-MOTION 9 SL

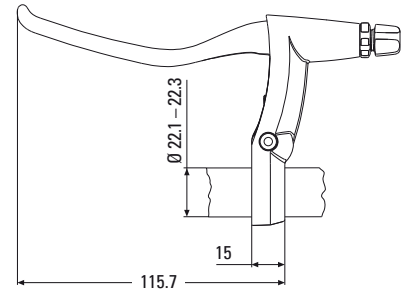

Brake lever SRAM BL 60

SHIFTERS

		i-MOTION 9 IBS SL	i-MOTION 9 SL
Hand brake lever	Version	i-MOTION 9 IBS (integrated hand brake lever)	i-MOTION 9 (single shifter)
	Shift cable lengths	1400 mm / 1500 mm / 1600 mm / 1700 mm	1400 mm / 1500 mm / 1600 mm / 1700 mm
	Shifter type	SRS Twist shifter with integrated brake lever	SRS Twist shifter
	Mounting location	right side of handlebar	right side of handlebar
	Compat. Gear hub	i-MOTION 9	i-MOTION 9
	Gear indicator	Window	Window
	Barrel adjuster	Indexed	Indexed
	Clamping diameter	22.1 – 22.3 mm	22.1 – 22.3 mm
	Straight handlebar ends	Minimum necessary length for shifter and handlebar grip = 150 mm	
	Cable routing	Continuous cable housing (pre-assembled)	Continuous cable housing (pre-assembled)
	Compatibility	Linear-Pull, Avid BB Disc	—
	Ratio	2.32	—
	Material	Cable path	24 mm
Reach Adjust		Yes	—
Adjusting screw		Yes	—
Lever size		4-finger	—
Material		Aluminum, forged	—
Weight		272 g	195 g
Shift cable		Stainless steel	Stainless steel
Housing		Cast aluminum	Cast aluminum
Grip cover		Thermoplastic elastomer	Thermoplastic elastomer
Frame clamp		Aluminum	Aluminum
Finish	Mercury silver painted	Mercury silver painted	

BRAKE LEVER

		SRAM BL 60	SRAM BL 60
Material	Version	SRAM BL 60, left	SRAM BL 60, right
	Mounting location	left side of handlebar	right side of handlebar
	Clamping diameter	22.1 – 22.3 mm	→
	Compatibility	Linear-Pull, Avid BB Disc	→
	Ratio	2.32	→
	Cable path	24 mm	→
	Reach Adjust	Yes	→
	Adjusting screw	Yes	→
	Lever size	4-finger	4-finger
	Weight	95 g	95 g
	Housing	Cast aluminum	→
	Lever	Aluminum, forged	→
	Frame clamp	Aluminum	→
Finish	Mercury silver painted	→	

CYCLE FRAME

Frame strength must be such that, the rear part of the frame does not undergo any permanent deformation when a max. braking torque of 250 Nm (2200 in.lbs.) is applied to the rear wheel.

Standard dropouts

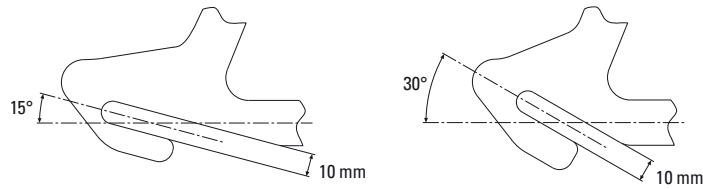

DROPOUTS

Only flat and not off-set versions.

Dropout thickness: 4 – 10 mm.

The dropouts must be parallel.

Dropout dimensions: *see figures on right.*

Vertical dropout

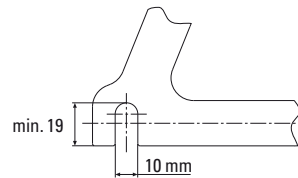

Dropout open towards rear

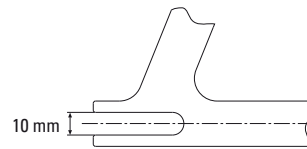

Rohloff dropout

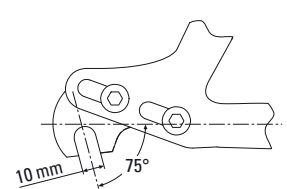

RETAINING WASHERS

The following table shows the permissible combinations of dropout and retaining washer.

Type of dropout					
Necessary Retaining washer on the left axle end (non drive side)	15L – blue dot	30L – yellow dot	67L – dark brown	180L – orange dot	75L – ocher dot
Necessary Retaining washer on the right axle end (drive side)	15R – red dot	30R – green dot	67R – pastel blue	180R – purple dot	75R – light purple dot

CRANKSET

The crankset and bottom bracket specifications must conform to the following details.

A = 48.8 mm ± 5 mm

B = 48.8 mm (rear chainline)

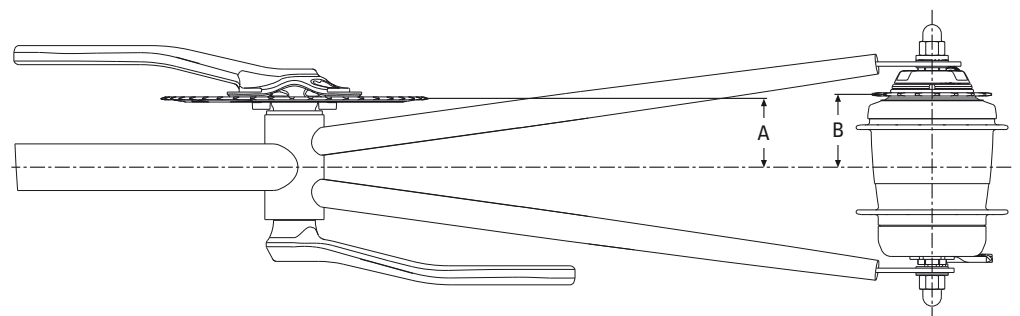

i-MOTION® 9

TECHNICAL DATA / ASSEMBLY REQUIREMENTS

FRAME AND CHAIN GUARD

For the frame and chain guard layout, the dimensions listed below have to be considered.

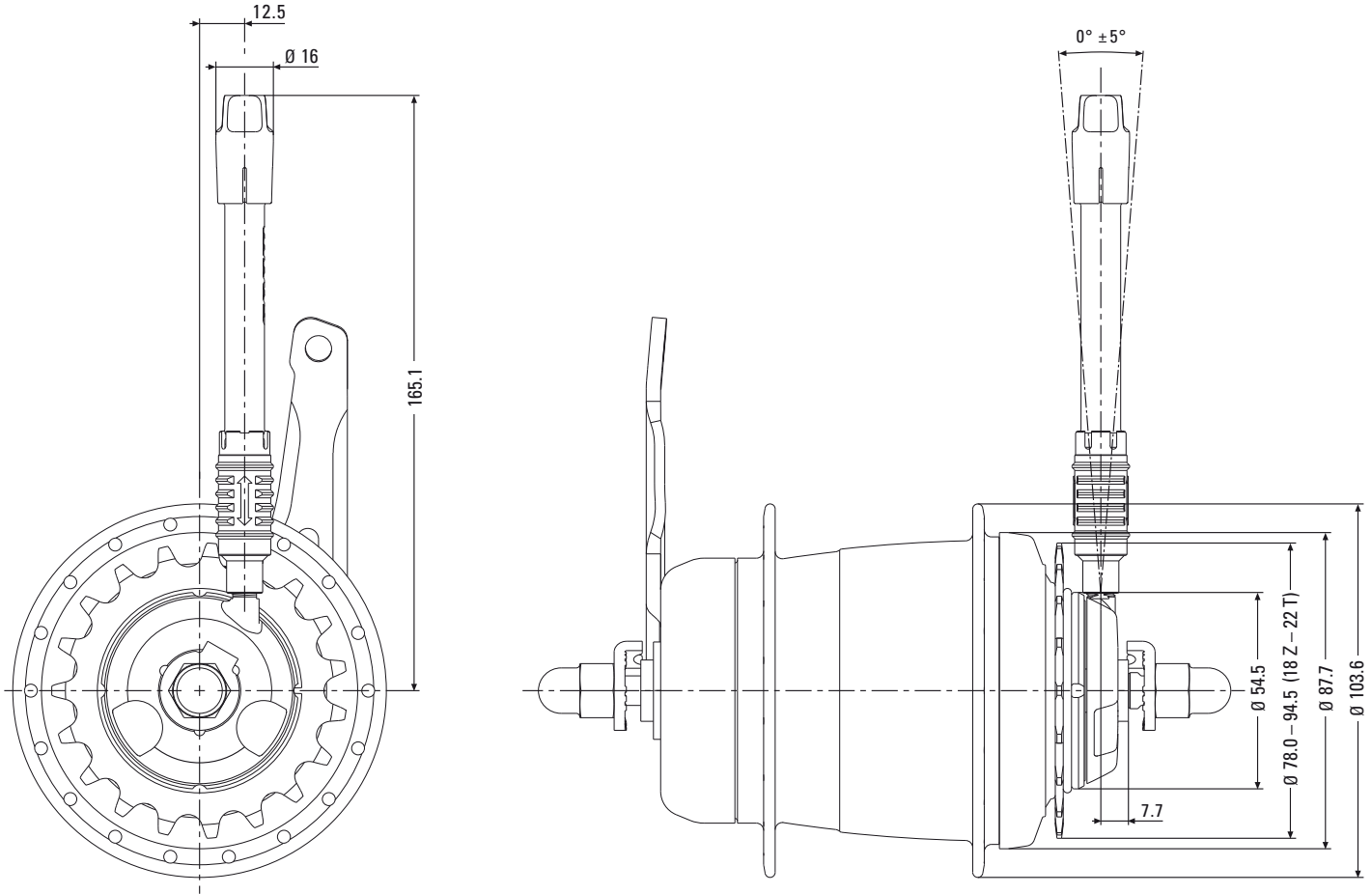

SHIFT CABLE ROUTING

Shift cable routing only along the chainstay
Only continuous cable housing (no open cable routing).
See the adjoining figure for attachment points.

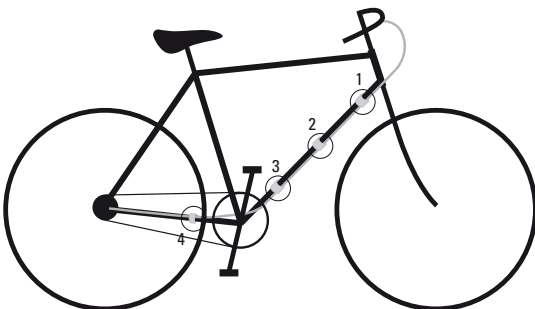

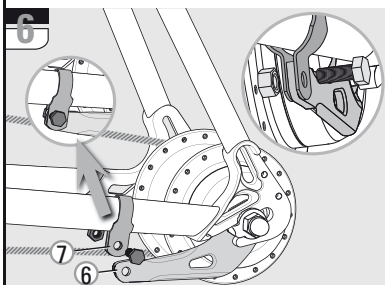
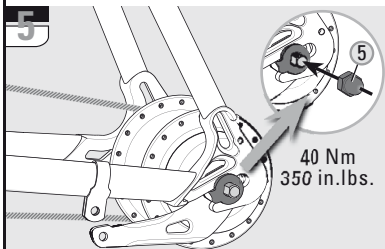
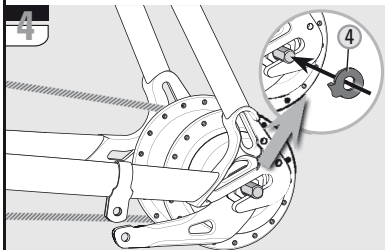
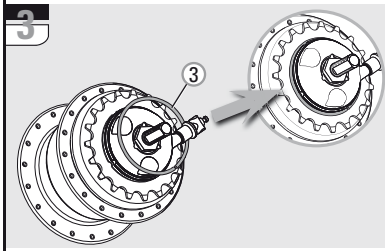
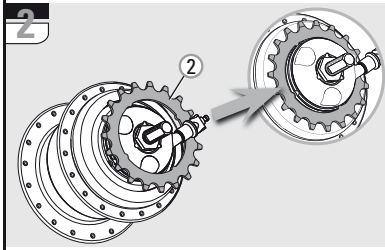
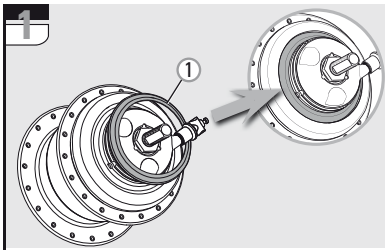

ASSEMBLY THE HUB

» Spoke the hub as normal.

1 Set the dust cap (1) onto the driver.
The curvature must point to the outside.

2 Set the sprocket (2) onto the driver.

3 Mount the sprocket circlip (3) onto the driver. Check for proper seating of the circlip.

» Hub version for Disc Brake:

Advice:
Read and observe the corresponding technical documentation for assembling the disc of the disc brake.

Caution:
Plane faces of the hub and disc and the threaded holes of the hub must be clean and free from oily and greasy substances.

» Place the rear wheel into the rear frame.

4 Slide one retaining washer each (4) onto each axle end. The correct version is shown in the table on page 5. The serrated face of the retaining washer must lie against the frame dropout. Where retaining washers have locating lugs, these must engage in the frame dropouts.

5 First fit the axle nut on the drive side and tighten to a torque of 40 Nm (350 in.lbs.). Then fit the axle nut (5) on the non-drive side and tighten to a torque of 40 Nm (350 in.lbs.).

6 If applicable, mount the brake lever (6) between the two straps of the frame clamp (7).

Caution:
The frame clamp must be fitted tightly on the frame without any play. Use a self-locking nut (M6)!
Tightening torque: 2 – 3 Nm (18 – 27 in.lbs.).

Caution:
Before setting out on any ride, always check the correct and trouble-free operation of the shift system and brakes.

i-MOTION® 9 ASSEMBLY

FITTING THE SHIFTER

7 Slide the shifter (1) onto the handlebar.

8 Slide the handlebar grip (2) onto the handlebar.

Caution: Never use lubricants or solvents when fitting handlebar grips. They have a safety function and must not come free from the handlebar.

9 Place the shifter on the handlebar grip and position so that you can use it comfortably. Tighten the clamping bolt (3). 3 mm Allen key, torque 3.5 – 4 Nm (31 – 35 in.lbs.).

Caution: Check that shifter and brake lever can be easily operated (if necessary, realign).
» Never ride without handlebar grips. The turning grip of the twist shifter could become loose. This can result in severe injuries.

Caution: Before setting out on any ride, always check the correct and trouble-free operation of the shift system and brakes.

FITTING THE SHIFT CABLE

Advice: Make sure that the cable housing length is sufficient to permit turning of the handlebar over its full range.
» Also bear in mind the effect of adjustable handlebars and stems on the cable housing length.
» Always use new, high-quality cables and compressionless cable housings with end caps.

10 Secure the cable housing to the frame.

Advice: The cable housing must be free to move at the securing points.
» Avoid tight bends when routing the shift cable.

11 Make sure that the shifter is set to 1st gear.

12 Slide the quick release fastener (4) on the connecting tube to the right. The opening (5) should now be visible.

13 Make the connection by sliding the opening of the connecting tube onto the catch (6) on the hub.

14 Slide the quick release fastener (7) on the connecting tube to the left until it snaps into place. The connection is now locked.

Caution: Before setting out on any ride, always check the correct and trouble-free operation of the shift system and brakes.

FITTING THE BRAKE LEVER SRAM BL 60

» Slide the brake lever onto the handlebar.

» Tighten the clamping bolt. 3 mm Allen key, torque 2 – 2.5 Nm (18 – 22 in.lbs.).

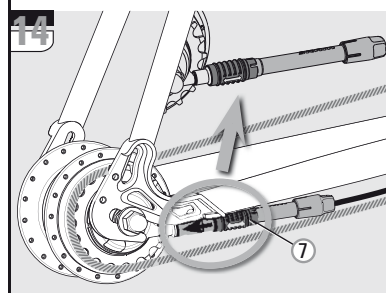
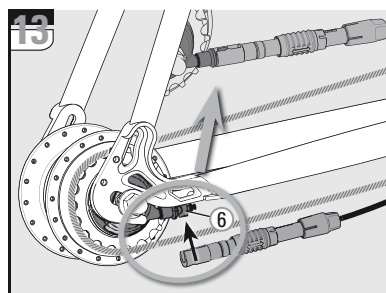
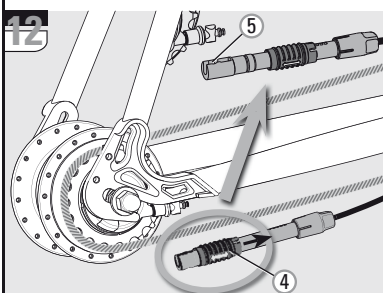
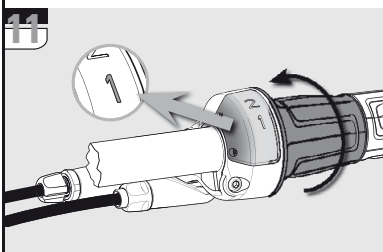
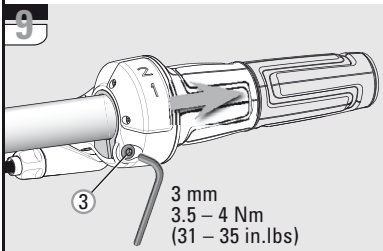
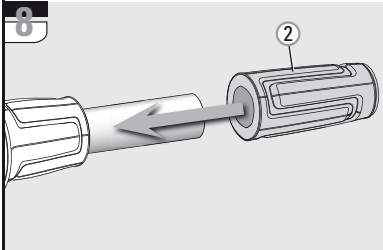
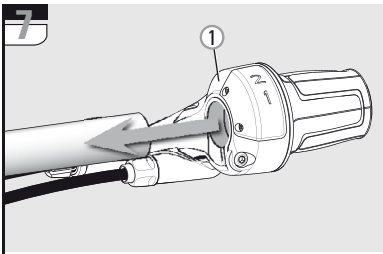

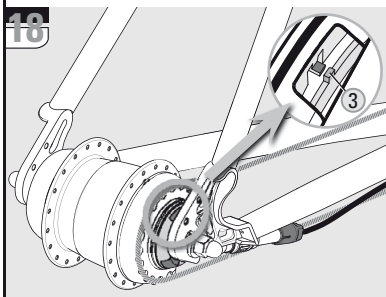
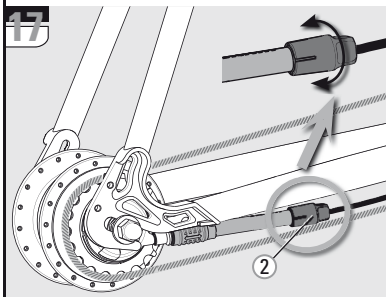
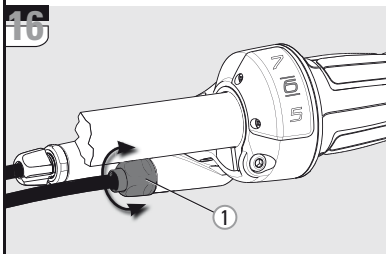
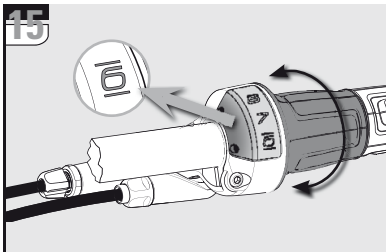

GEAR ADJUSTMENT

» Before adjusting the gears, shift several times between 1st and 9th gears and then back again, so that the shift cable seats itself correctly.

15 Turn the twist shifter from 7th to 6th gear.

16 To make adjustments, use the barrel adjuster (1) on the shifter

17 or the barrel adjuster (2) on the connecting tube.

18 Turn the barrel adjuster until the yellow / red marks (3) in the window of the gear hub are aligned.

FITTING THE BRAKE CABLE

Caution: The brake lever on the i-MOTION IBS shifter and the brake lever i-BRAKE 60 BL is only compatible with the following brakes: Avid BB Disc and Linear-Pull compatible brakes.

Advice: Make sure that the cable housing length is sufficient to permit turning of the handlebar over its full range.
» Also bear in mind the effect of adjustable handlebars and stems on the cable housing length.
» Always use new, high-quality cables and compressionless cable housings with end caps.

19 Turn the cable adjustment screw (1) and the counter nut (2) so that the cable slot is aligned with the slot on the bottom of the brake lever housing.

20 Pull the brake lever to the handlebar and guide the inner cable into the housing.
Hook the nipple (3) of the inner cable into the recess (4) in the brake lever.

» Follow the brake manufacturer's instructions when fitting the brake cable and adjusting the brakes.

Caution: Check that the brake is operating in a correct and trouble-free manner.

Reach adjust of the hand brake lever: so that you can operate the brake lever on the shifter comfortably, set the reach to match your hand size.

21 Use a 2 mm Allen key to set the distance between the brake lever and the handlebar.

Caution: Every time you adjust the reach, check and correct the brake cable tension to ensure good brake performance.

Advice: Read and observe the operating manual and technical documentation of the brake manufacturer.

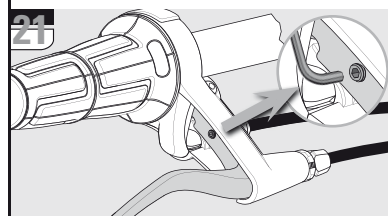
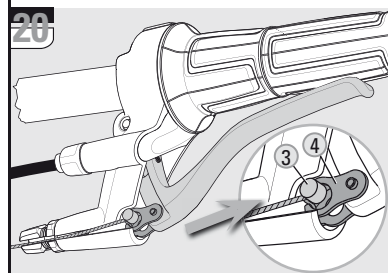
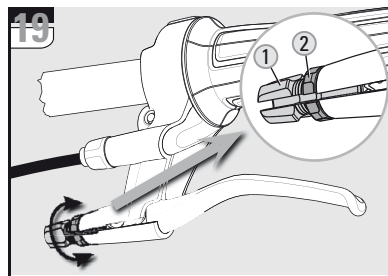

i-MOTION® 9 OPERATION

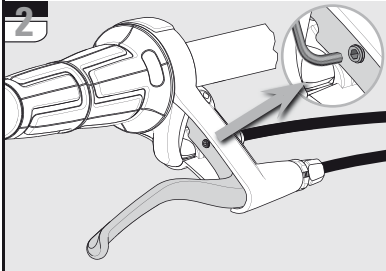
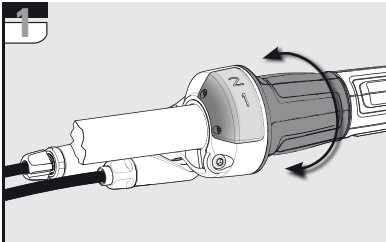

SHIFTING

- 1** Shift gears by turning the twist shifter on the right side of the handlebar.
- » You can shift gear while stationary or when riding.
 - » Ensure you shift to a lower gear in plenty of time before hills.
 - » The quickest and smoothest gear shifts are achieved by shifting while pedaling using only a low force.

BRAKING

When descending long and steep hills, always use the second (front) brake as well, to prevent overheating of the brakes.

Caution: Before setting out on any ride, always check the correct and trouble-free operation of the shift system and brakes.

Caution: Excessive heating of the hub caused by back pedal braking may result in loss of lubricant and cause sharper braking. Relubricating of the brake sleeve with special grease is then necessary. See "DISMANTLING/ ASSEMBLY OF THE HUB - NOT DRIVE SIDE", page 16.

Reach adjust of the hand brake lever:

so that you can operate the brake lever on the shifter comfortably, set the reach to match your hand size.

- 2** Use a 2 mm Allen key to set the distance between the brake lever and the handlebar.

Caution: Every time you adjust the reach, check and correct the brake cable tension to ensure good brake performance.

Advice: Read and observe the operating manual and technical documentation of the brake manufacturer.



SERVICE

To maintain optimal performance and durability of your components, periodic maintenance is required. We recommend that you have your components serviced every 2 year or 5000 km by a qualified bicycle mechanic.

CLEANING

Your SRAM i-MOTION 9 components are well protected against adverse environmental effects.

- » The rear wheel hub is not completely waterproof. However, do not use water under pressure (such as pressure washers or water jets) for cleaning to prevent malfunctions due to water penetration.
- » During the winter season, you should clean your bicycle in shorter intervals so that winter road salt cannot cause any damage.
- » Do not use aggressive cleaners.
- » Clean dirty chains before oiling. Let cleaner set for only a few minutes and rinse with water. Do not oil chain until completely dry.

LUBRICATION

- » The rear wheel hub is provided with permanent lubrication and is almost maintenance-free under normal conditions.
- » When dismantling/assembling the gear unit, observe the lubrication guidelines. See "DISMANTLING / ASSEMBLY OF THE HUB", from page 18.
- » Regular lubrication will extend the chain's service life.

REPAIR WORK

Caution: Unauthorized work on your components could endanger you and your warranty may become void.

Back pedal brake

If braking is too sharp, the brake sleeve has to be re-lubricated with special grease. See "DISMANTLING/ ASSEMBLY OF THE HUB - NOT DRIVE SIDE", page 18.

WEAR PARTS

Brake liners or brake sleeve, brake cables, shift cables, handlebar grips, sprockets, and bike chains are wear parts. Please check these parts regularly and replace them well before they are worn out.

Other topics	Page
GEAR ADJUSTMENT	12
REMOVING THE REAR WHEEL	12
FITTING THE REAR WHEEL	13
EXCHANGING THE GEAR UNIT	14
DISMANTLING AND ASSEMBLING THE HUB	16
CHANGING THE SHIFT CABLE	20
CHANGING THE BRAKE CABLE	22
TROUBLESHOOTING	23

i-MOTION® 9 MAINTENANCE

GEAR ADJUSTMENT

- 1** Turn the twist shifter from 7th to 6th gear.
- 2** To make adjustments, use the barrel adjuster (1) on the shifter or the barrel adjuster (2) on the connecting tube.
- 3**
- 4** Turn the barrel adjuster until the yellow / red marks (3) in the window of the gear hub are aligned.

REMOVING THE REAR WHEEL

- 5** Turn the twist shifter to 1st gear.
- 6** Slide the quick release fastener (1) on the connecting tube to the right.
- 7** Undo the connection by removing the connecting tube in a downwards direction.
- 8** Loosen the axle nuts (2) and take these and the underlying retaining washers (3) off. If fitted, unscrew (4) the frame clamp of the brake lever.

» Remove the rear wheel.

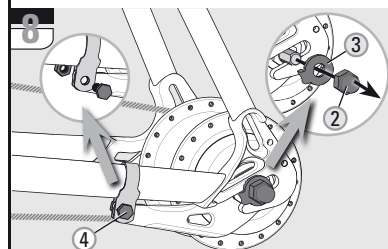
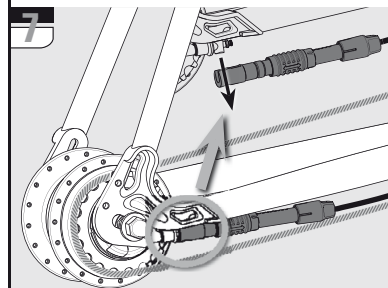
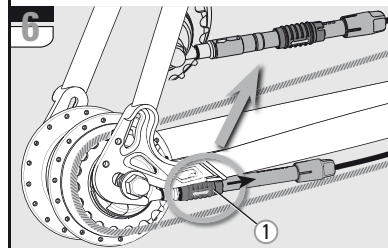
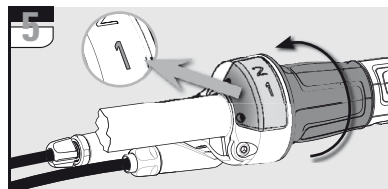
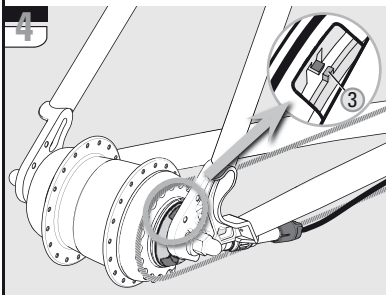
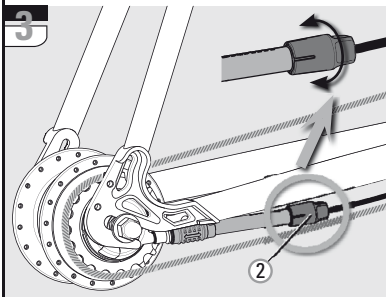
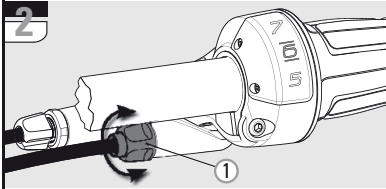
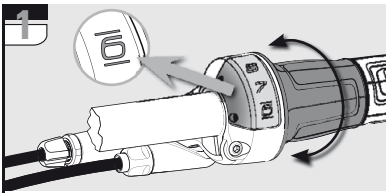

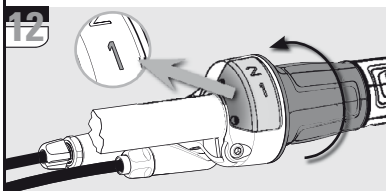
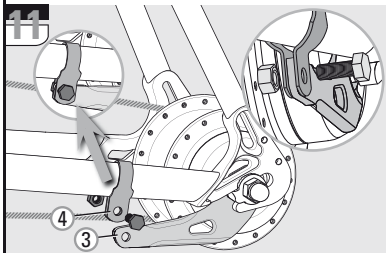
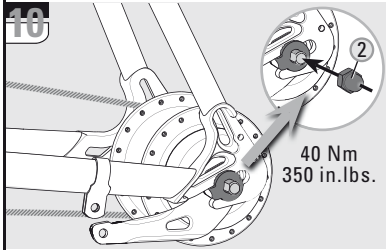
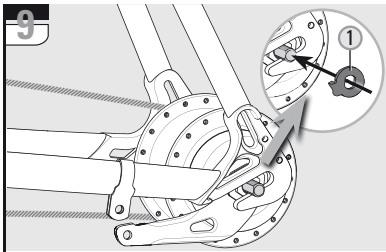

FITTING THE REAR WHEEL

» Place the rear wheel into the rear frame.

9 Place one retaining washer each (1) onto each axle end. The serrated face of the retaining washer must lie against the frame dropout. Where retaining washers have locating lugs, these must engage in the frame drop-outs.

10 First fit the axle nut on the drive side and tighten to a torque of 40 Nm (350 in.lbs.). Then fit the axle nut (2) on the non-drive side and tighten to a torque of 40 Nm (350 in.lbs.).

11 If applicable, mount the brake lever (3) between the two straps of the frame clamp (4).

Caution: The frame clamp must be fitted tightly on the frame without any play. Use a self-locking nut (M6)! Tightening torque: 2 – 3 Nm (18 – 27 in.lbs.).

12 Make sure that the shifter is set to 1st gear.

13 Slide the quick release fastener (5) on the connecting tube to the right. The opening (6) should now be visible.

14 Make the connection by sliding the opening of the connecting tube onto the catch (7) on the hub.

15 Slide the quick release fastener (8) on the connecting tube to the left until it snaps into place. The connection is now locked.

Caution: Before setting out on any ride, always check the correct and trouble-free operation of the shift system and brakes.

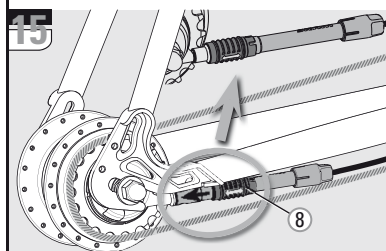
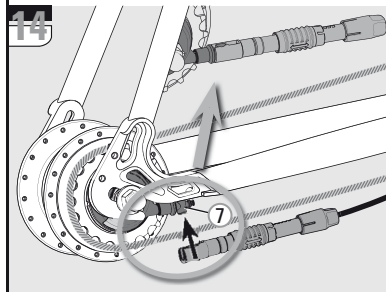
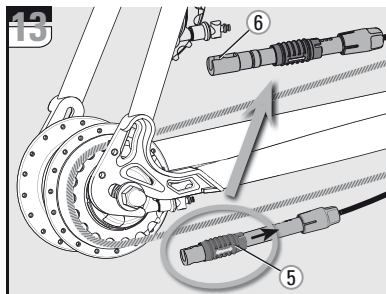

i-MOTION® 9 MAINTENANCE

EXCHANGING THE GEAR UNIT

1 Detach the circlip (1).

Caution: The circlip is spring force loaded. Take off the sprocket (2) and the small outer dust cap (3).

2 Clamp the drive side of the axle with the two flats of the axle in a vise.

3 Unscrew the nut (4) and the large axle nut (5) from the axle. Wrench size 17 mm and 27 mm (SRAM tool part no. 00 0924 003 000 for wrench size 27 mm).

For the no-brake hub version and disc brake, the axle nut (4) and the underlying adjusting cone should be unscrewed from the axle. Wrench size 17 mm and 13 mm.

4 Hub version with back pedal brake: Take off the lever cone (6) and the ball retainer (7).

4 Hub versions without brake and Disc Brake: take the ball retainer (7) out.

5 Hub version with back pedal brake: Remove the brake sleeve (8).

6 Remove the hub shell (9) by jerking upwards.

Advice: The outer large dust cap (10) is a very tight fit. Its removal will result in it being damaged. Replace with a new cap during reassembly. The gear unit can be removed by tapping a rubber mallet on the axle on the non-drive side of the shell. To do this, remove the hub from the vise.

» Clamp the new gear unit on the drive side of the axle in the vise.

Caution: Use only SRAM special grease, part no. 0369 135 200 / ... 201. Lubricate ball retainers and ball tracks only with SRAM Ball Bearing Grease. Part no. 0369.001.015

Lubrication: Lightly grease the ball tracks (11) and the tothing (12) on the inside of the hubshell.

Hub version with back pedal brake: Lightly grease the brake cylinder (13).

7 Position the hub shell. Turning slightly to the left/right eases positioning.

Ensure that the hub shell is correctly seated on the ball retainer (14).

8 Hub version with back pedal brake: Turn the shell in a clockwise direction until it reaches the stop. This ensures that the rollers (15) of the brake can fall back and that the brake sleeve can be mounted.

» Hub version with back pedal brake:

Lubrication: Clean the brake sleeve and completely coat its outer surface only with grease.

Caution: Use only SRAM special grease, part no. 0369 135 200 / ... 201.

9 Insert the brake sleeve. The side with only one recess must point downwards. The angled spring end (16) must be positioned in this recess (17).

Advice: The brake sleeve must be renewed, if, as a result of wear, the pattern on its outer surface is scarcely visible.

Lubrication: Clean the ball retainer (18) and grease it using SRAM Ball Bearing Grease (part no. 0369.001.015).

10 Insert the ball retainer (18). The side with the balls must point downwards.

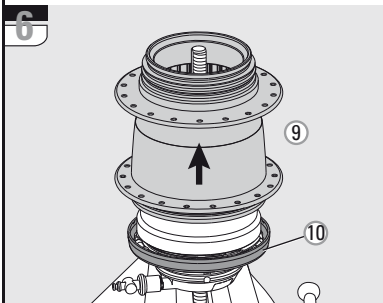
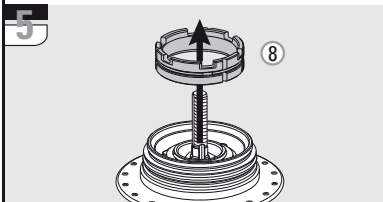
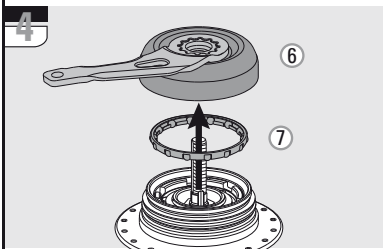
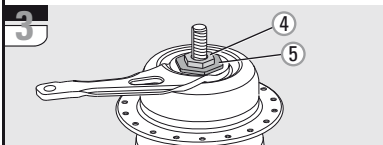
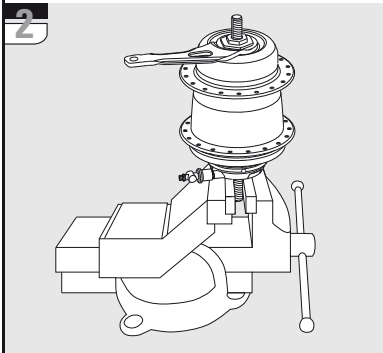
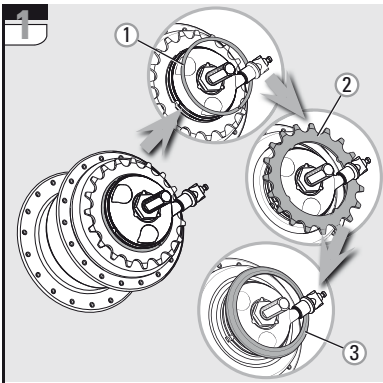

i-MOTION® 9 MAINTENANCE

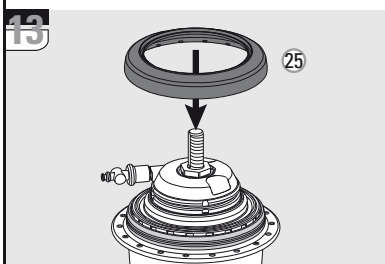
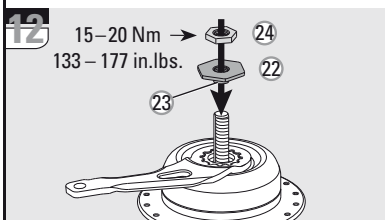
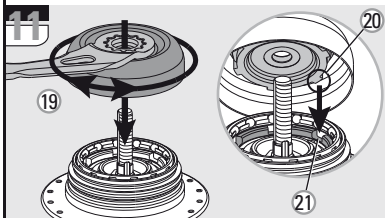
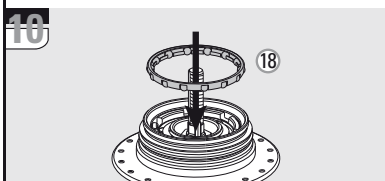
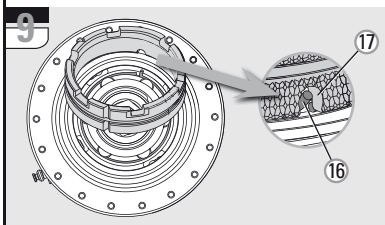
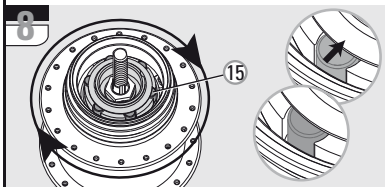
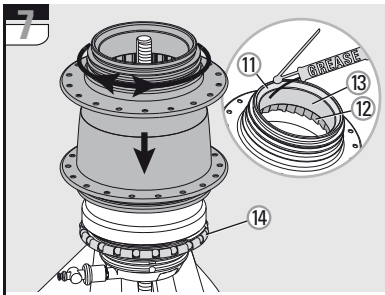

11 Hub version with back pedal brake:
Fit the lever cone (19).
By turning to the left and right, bring the lever cone (19) into its final position. The locating lugs (20) of the lever cone will then lie in the recesses (21) of the brake sleeve.

12 Hub version with back pedal brake:
Screw the large axle nut (22) with the projection (23) downwards onto the axle. Wrench size 27 mm.

» Hub versions without brake and disc brake:
screw the adjusting cone onto the axle. Wrench size 13 mm.

12 Position the bearing in a play-free manner and tighten using nut (24). Wrench size 17 mm. Tightening torque 15 – 20 Nm (133 – 177 in.lbs.).

Caution:
Test the play of the bearing and correct if required.

» Clamp the hub with the other axle side in the vise.

13 Press the large outer plastic dust cap (25) onto the hub until it engages.

Advice:
Use a new dust cap after each dismantling.

14 Place the small inner dust cap (26) onto the driver. The curvature must point to the outside.

15 Set the sprocket (27) onto the driver.

16 Mount the sprocket circlip (28) onto the driver. Check for proper seating of the circlip.

» Remove the hub from the vise.

» Fit the rear wheel into the rear frame as described on page 15. Adjust the gears as described on page 14.

Caution:
Before setting out on any ride, always check the correct and trouble-free operation of the shift system and brakes.

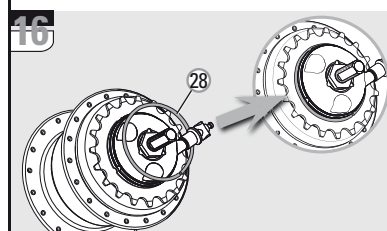
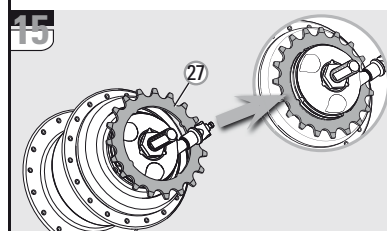
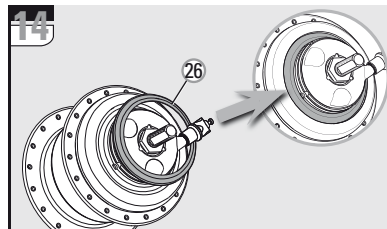

i-MOTION® 9 MAINTENANCE

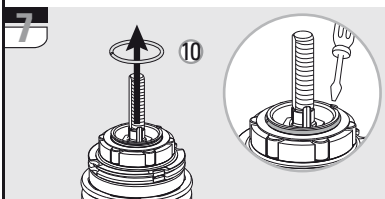
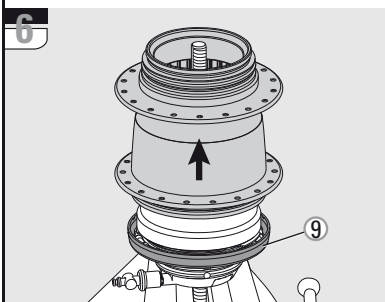
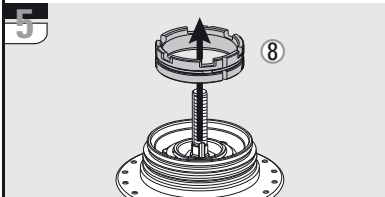
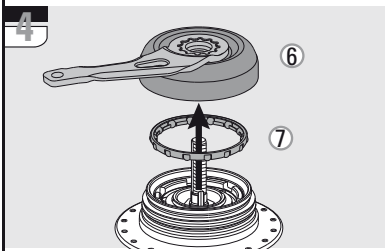
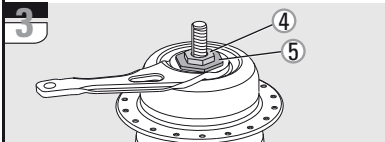
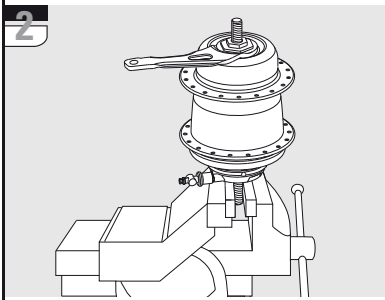
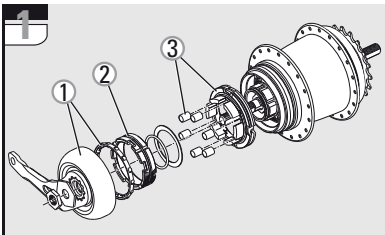

DISMANTLING THE HUB NOT DRIVE SIDE

Caution:
During dismantling, **one** side of the hub must always remain closed, to prevent the gear unit from coming apart.

Advice:
On the non-drive side of the hub, **1** work may only be carried out on the following parts:

- lever cone / adjusting cone with ball retainer (1)
- brake sleeve (2).
- Roller guide ring and rollers (3)

Work on the brake cone / adjusting cone and ball retainer:

2 Clamp the drive side of the axle with the two flats of the axle in a vise.

3 Unscrew the nut (4) and the large axle nut (5) from the axle. Wrench size 17 mm and 27 mm (SRAM tool part no. 00 0924 003 000 for wrench size 27 mm).

For the no-brake hub version and disc brake, the axle nut (4) and the underlying adjusting cone should be unscrewed from the axle. Wrench size 17 mm and 13 mm.

4 Hub version with back pedal brake: Take off the lever cone (6) and the ball retainer (7).

4 Hub versions without brake and Disc Brake: take the ball retainer (7) out.

» Lubrication and assembly details can be found on the following page.

Work on the brake sleeve:

(Hub version with back pedal brake)

» Dismantle the hub as previously described ("Work on brake cone / adjusting cone and ball retainer")

5 Remove the brake sleeve (8).

Advice:
The brake sleeve must be renewed, if, as a result of wear, the pattern on its outer surface is scarcely visible.

» Lubrication and assembly details can be found on the following page.

Work on the roller guide ring and rollers:

(Hub version with back pedal brake)

» Dismantle the hub as previously described ("work on brake cone / adjusting cone and ball retainer" and "work on brake sleeve").

6 Remove the hub shell by jerking upwards.

Advice:
The outer large dust cap (9) is a very tight fit. Its removal will result in it being damaged. Replace with a new cap during reassembly.

The gear unit can be removed by tapping a rubber mallet on the axle on the non-drive side of the shell. To do this, remove the hub from the vise.

7 Remove the circlip (10).

8 Take off the washer (11) and take the 6 rollers (12) out of the roller guide ring.

9 Take off the roller guide ring (13).

Caution:
Further dismantling is not permitted, as otherwise the gear unit comes apart. Reassembly could then only be undertaken by SRAM.

» Lubrication and assembly details can be found on the following page.

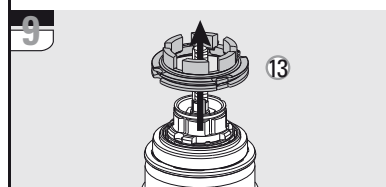
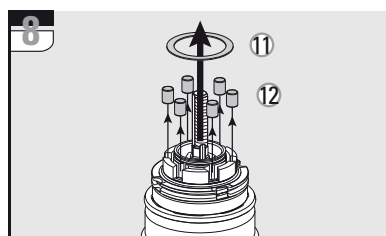

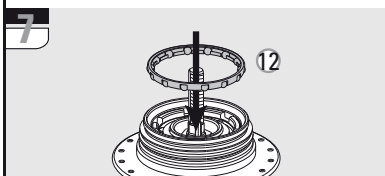
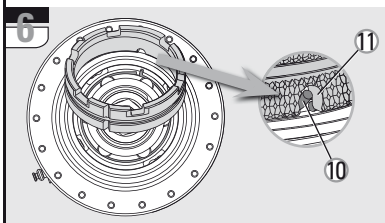
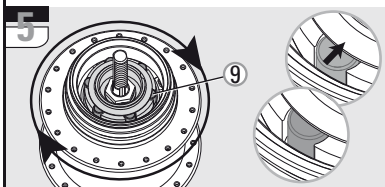
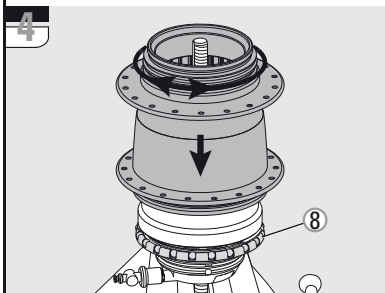
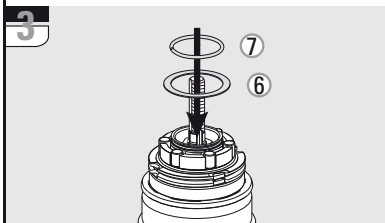
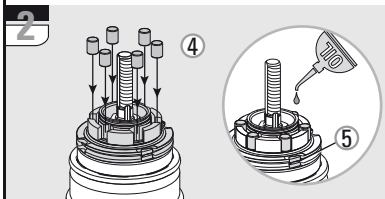
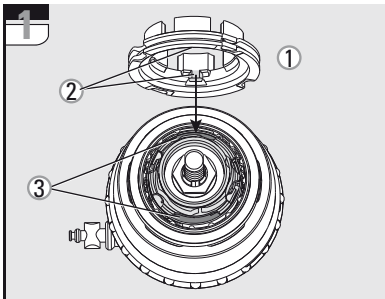

ASSEMBLING THE HUB NOT DRIVE SIDE

Work on the roller guide ring and rollers:

1 Seat the roller guide ring (1) on the gear unit.

Advice:
The two lugs (2) of the roller guide ring must mesh in the long recesses (3).

2 Insert the 6 rollers (4) in the roller guide ring.

Lubrication:
Oil the 6 rollers and the two pawls (5) of the roller guide ring. Use only standard bicycle oil.

3 Place the washer (6) on the roller guide ring and fit the circlip (7).

4 Position the hub shell. Turning slightly to the left/right eases positioning. Ensure that the hub shell is correctly seated on the ball retainer (8).

5 Hub version with back pedal brake: Turn the shell in a clockwise direction as far as it will go. This ensures that the rollers (9) of the brake can fall back and that the brake sleeve can be mounted.

Work on the brake jacket: (Hub version with back pedal brake)

Lubrication:
Clean the brake sleeve and completely coat its outer surface only with grease.

Caution:
Use only SRAM special grease, part no. 0369 135 200 / ... 201.

6 Insert the brake sleeve. The side with only one recess must point downwards. The angled spring end (10) must be positioned in this recess (11).

Advice:
The brake sleeve must be renewed, if, as a result of wear, the pattern on its outer surface is scarcely visible.

Work on the brake cone / adjusting cone and ball retainer:

Lubrication:
Clean the ball retainer (12) and grease it using SRAM Ball Bearing Grease (part no. 0369.001.015).

7 Insert the ball retainer (12). The side with the balls must point downwards.

8 Hub version with back pedal brake: Fit the lever cone (13). By turning to the left and right, bring the lever cone (13) into its final position. The locating lugs (14) of the lever cone will then lie in the recesses (15) of the brake sleeve.

9 Hub version with back pedal brake: Screw the large axle nut (16) with the projection (17) downwards onto the axle. Wrench size 27 mm

» Hub versions without brake and disc brake: Screw the positioning cone onto the axle. Wrench size 13 mm.

9 Position the bearing in a play-free manner and tighten using nut (18). Wrench size 17 mm. Tightening torque 15 – 20 Nm (133 – 177 in.lbs.). Hub version i-BRAKE: Instead of the nut mount the centering bushing with the projection upwards onto the axle. Wrench size 17 mm.

Caution:
Test the play of the bearing and correct if required.

» Remove the hub from the vise.

» Fit the rear wheel into the rear frame as described on page 15. Adjust the gears as described on page 14.

Caution:
Before setting out on any ride, always check the correct and trouble-free operation of the shift system and brakes.

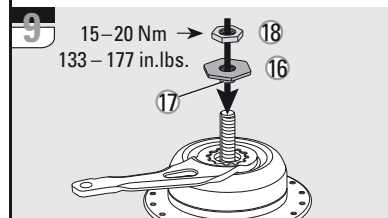
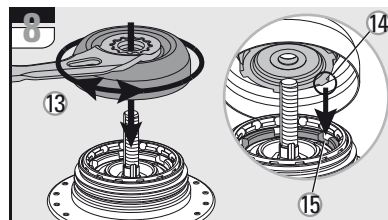

i-MOTION® 9 MAINTENANCE

DISMANTLING THE HUB DRIVE SIDE

Caution:
During dismantling, **one** side of the hub must always remain closed, to prevent the gear unit from coming apart.

Advice:
On the drive side of the hub, work **1** may only be carried out on the following parts:
– fixed cone (1) with ball retainer (2)

Work on the fixed cone and ball retainer:

2 Detach the circlip (3), sprocket (4) and the small outer dust cap (5).

Caution:
The large outer plastic dust cap (6) must remain fitted, to prevent the gear unit from coming apart.

4 Clamp the non-drive side of the axle with the two flats of the axle in a vise.

5 Unscrew nut (7) from the axle.
5 Wrench size 17 mm.

6 Take off the fixed cone (8) together the washer (9) above it.

7 Take off the ball retainer (10).

Caution:
Further dismantling is not permitted, as otherwise the gear unit comes apart. Reassembly could then only be undertaken by SRAM.

» Lubrication and assembly details can be found on the following page.

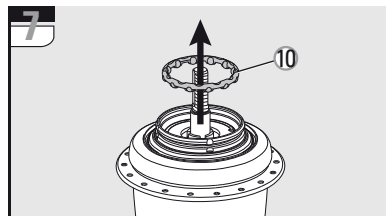
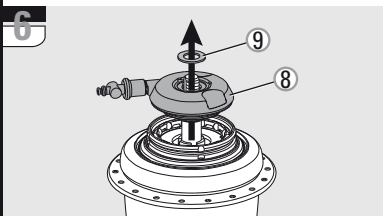
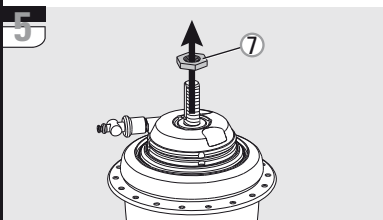
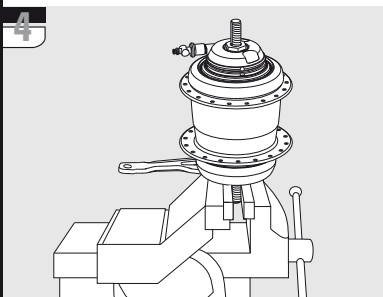
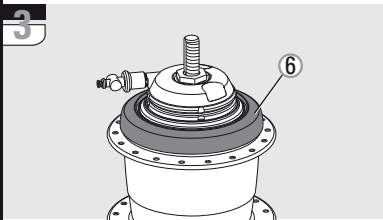
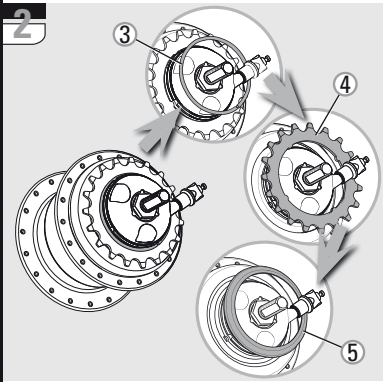
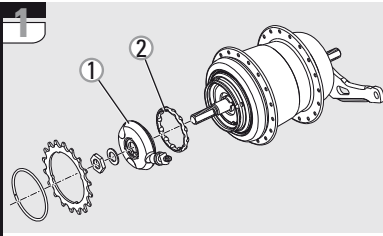

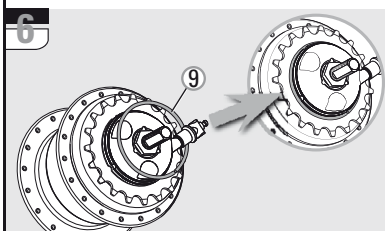
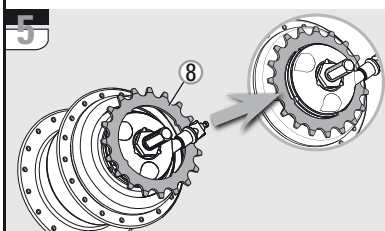
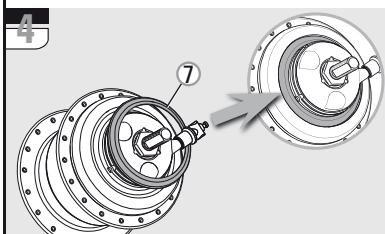
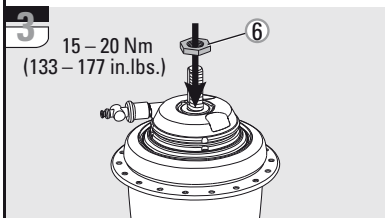
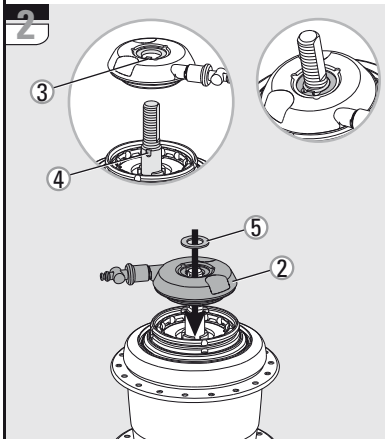
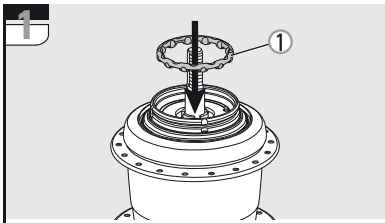

ASSEMBLING THE HUB DRIVE SIDE

Work on the fixed cone and ball retainer:

Lubrication:
Clean the ball retainer (1) and grease it using SRAM Ball Bearing Grease (part no. 0369.001.015).

1 Insert the ball retainer (1). The side with the balls must point downwards.

2 Push the fixed cone (2) onto the axle.

Advice:
The lug (3) of the fixed cone must mesh in the axle recess (4).

2 Place the washer (5) on top of it.

3 Screw the nut (6) onto the axle. Wrench size 17 mm, tightening torque 15 – 20 Nm (133 – 177 in.lbs.)

4 Place the small inner dust cap (7) onto the driver. The curvature must point to the outside.

5 Set the sprocket (8) onto the driver.

6 Mount the sprocket circlip (9) onto the driver. Check for proper seating of the circlip.

» Remove the hub from the vise.

» Fit the rear wheel into the rear frame as described on page 15. Adjust the gears as described on page 14.

Caution:
Before setting out on any ride, always check the correct and trouble-free operation of the shift system and brakes.

i-MOTION® 9 MAINTENANCE

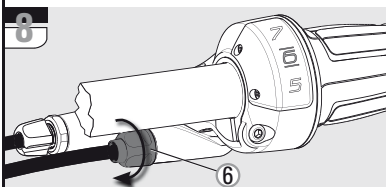
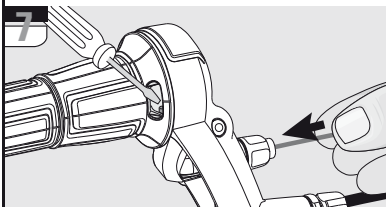
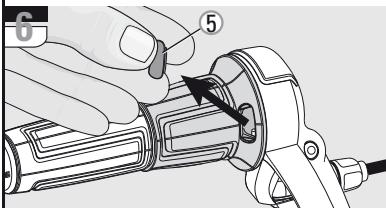
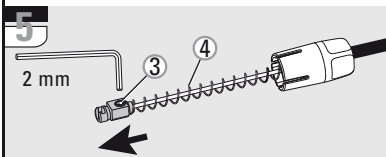
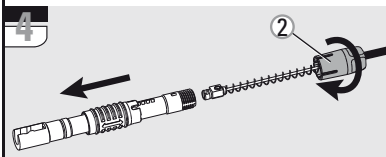
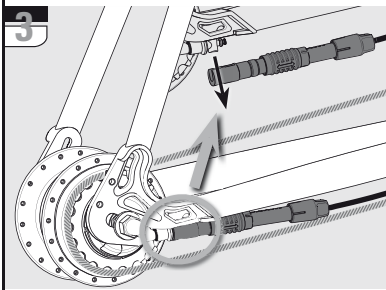
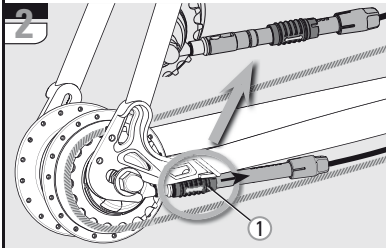
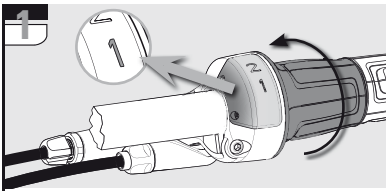

CHANGING THE SHIFT CABLE



Advice:

Always use new, high-quality cables and compressionless cable housings with end caps.

1 Turn the twist shifter to 1st gear.

2 Slide the quick release fastener (1) on the connecting tube to the right.

3 Undo the connection by removing the connecting tube in a downwards direction.

4 Unscrew the barrel adjuster (2) from the connecting tube and pull the connecting tube from the shift cable.

5 Use a 2 mm Allen key to loosen the clamping screw (3) in the nipple and pull this and the spring (4) behind it off the inner cable.

6 Make sure that the shifter is set to 1st gear.

7 Remove the cap (5) from the shifter. The nipple of the inner cable is now visible.

8 Push or pull the old inner cable out of the shifter, e.g. using a small screwdriver.

» Guide the new inner cable into the cable inlet, through the shifter and the new cable housing. Pull the cable tight.

» Insert the cap in the shifter.

9 Screw in the shifter barrel adjuster (6) as far as it will go.

Fitting the nipple without assembly tool:

9 Push the barrel adjuster (7) onto the inner cable. Pull the inner cable tight and shorten by 82 mm (measured from the front edge of the barrel adjuster).

10 Push the spring (8) onto the inner cable. Guide the inner cable into the nipple (9) and tighten the clamping screw with a 2 mm Allen key. Tightening torque 1.5 Nm (13 in.lbs.).

Fitting the nipple with assembly tool (SRAM part no. 00.0991.002.000):

11 Clamp the assembly tool in the vise.

12 Push the barrel adjuster (10) onto the inner cable. Route the inner cable through the assembly tool and push the barrel adjuster onto the assembly tool.

13 Thread the spring onto the inner cable. The spring should, for ease of mounting, be clamped, as shown in the figure.

14 Pull the inner cable tight and cut it off at the end of the assembly tool.

15 Lift the inner cable slightly from the assembly tool and guide it into the nipple.

16 Place the nipple in the tool and tighten the clamping screw with a 2 mm Allen key. Tightening torque: 1.5 Nm (13 in.lbs.).

i-MOTION® 9 MAINTENANCE

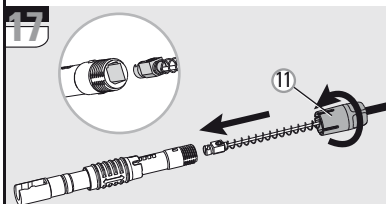
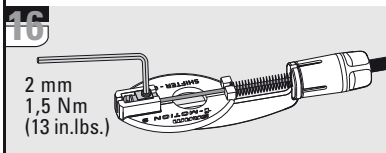
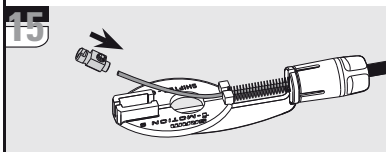
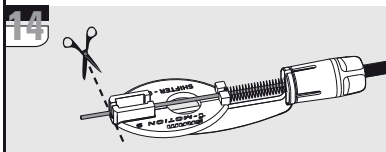
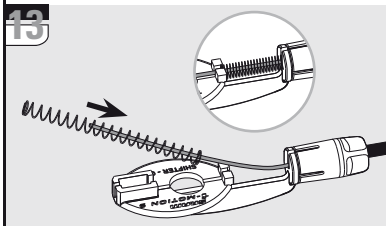
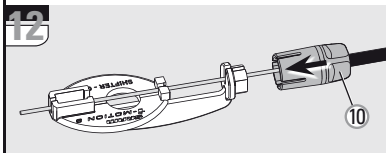
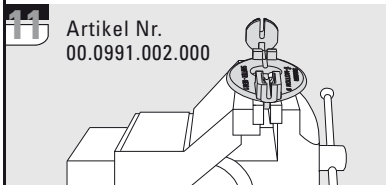
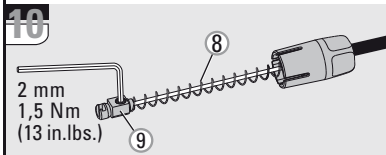
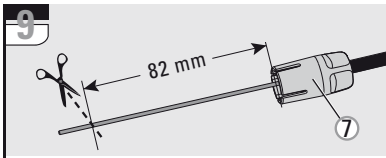

17 Push the cable end with the nipple into the connecting tube.

Advice:
When doing this, ensure that the flattened corner of the nipple matches the corresponding shape in the connecting tube.

Screw the barrel adjuster (11) as far as it will go onto the connecting tube.

1 Make sure that the shifter is set to 1st gear.

18 Slide the quick release fastener (12) on the connecting tube to the right. The opening (13) should now be visible.

19 Make the connection by sliding the opening of the connecting tube onto the catch (14) on the hub.

20 Slide the quick release fastener (15) on the connecting tube to the left until it snaps into place. The connection is now locked.

» Adjust the gears as described on page 14.

Caution:
Before setting out on any ride, always check the correct and trouble-free operation of the shift system and brakes.

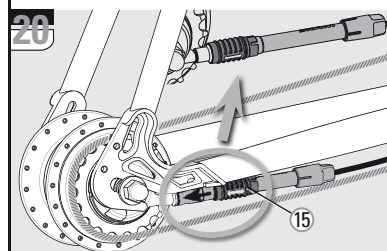
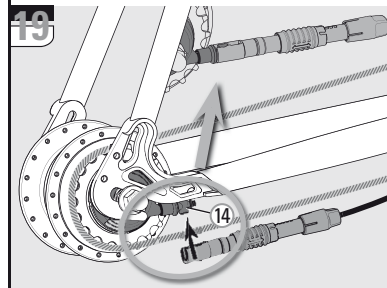
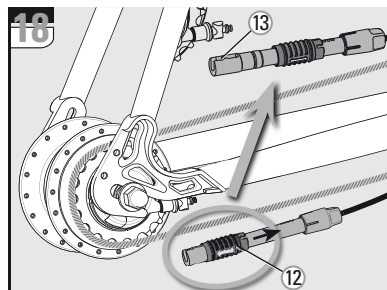

i-MOTION® 9 MAINTENANCE

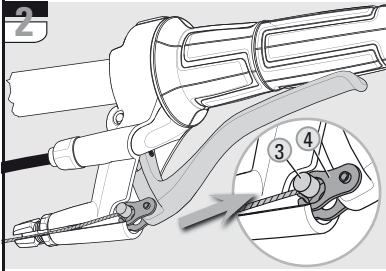
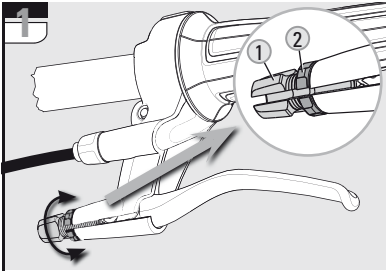

CHANGING THE BRAKE CABLE



Advice:

Always use new, high-quality cables and compressionless cable housings with end caps.

» Loosen the inner cable from the brake.



Turn the cable adjustment screw (1) and the counter nut (2) so that the cable slot is aligned with the slot on the bottom of the brake lever housing.



Pull the brake lever to the handlebar and unhook the nipple (3) of the inner cable from the recess (4) in the brake lever. Remove the old brake cable completely.



Pull the brake lever to the handlebar and guide the new inner cable into the housing. Hook the nipple (3) of the inner cable into the recess (4) in the brake lever.

» Follow the brake manufacturer's instructions when fitting the brake cable and adjusting the brakes.



Caution:

Check that the brake is operating in a correct and trouble-free manner.

TROUBLESHOOTING

Problem	Cause	Remedy
Shifting difficulties:	Incorrect gear adjustment.	Adjust the gears. Page 14.
	The shift cable for the cable housing is damaged.	Renew the shift cable and cable housing. Page 22.
	The connecting tube is touching the bike frame or is twisted.	The connecting tube must be freely connected to the hub without being twisted. Remove the cause of twisting (e.g. by correctly aligning the rear wheel).
	The connecting tube is twisted: – Left and right retaining washers have been interchanged. – Incorrect retaining washers fitted.	The connecting tube must be freely connected to the hub without being twisted. Fit the correct retaining washers. Page 7.
The pedals go forwards when freewheeling:	The chain tension is too tight.	Slacken the chain tension.
	The bearing adjustment is too tight.	Readjust the bearing. Page 17.
	Locknut of the lever cone / adjusting cone is loose.	Readjust the bearing and tighten the locknut. Page 17, figure 12, no. 24.
The back pedal brake is too sharp or locked:	The brake sleeve is no longer lubricated.	Lubricate the brake cylinder of the hub shell and the brake sleeve (if necessary renew). Page 18 "Work on the brake sleeve".
Grinding noise:	Dust cap incorrectly fitted or defective.	Fit the dust cap correctly (if necessary renew). Page 17, figure 13, no. 25.

CYCLE FRAME

Frame strength must be such that, the rear part of the frame does not undergo any permanent deformation when a max. braking torque of 250 Nm (2200 in.lbs.) is applied to the rear wheel.

DROPOUTS

- Only flat and no off-set versions.
- Dropout thickness: 4 – 8 mm.
- Dropouts must be parallel.
- Slot width at rear dropout: max. 10^{0.5} mm.

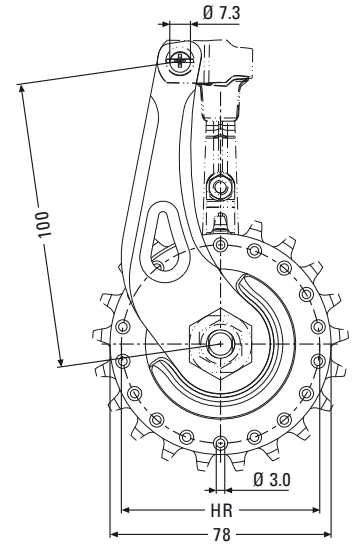
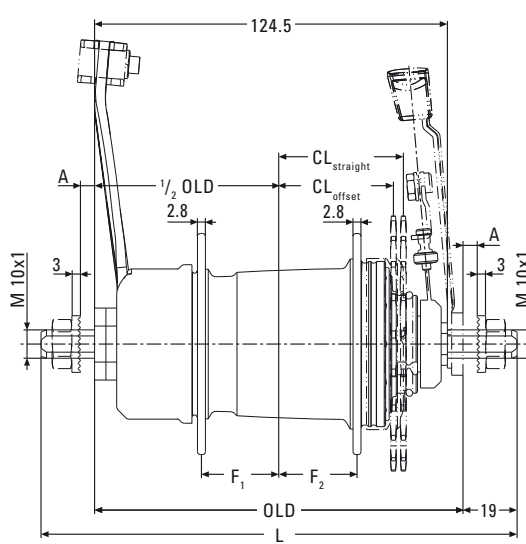

Version with back pedal brake

GEAR HUBS

	i-MOTION 3 w. back pedal brake	i-MOTION 3 disc brake compatib.	i-MOTION 3 without brake
Speeds	3	3	3
Brake	With back pedal brake	Adaptor for disc brake	Without brake
Over Locknut Dim., OLD	130 mm	135 mm	130 mm
Length, L	178 mm (and 168 mm)	178 mm	178 mm (and 168 mm)
Ends diameter	M 10x1	M 10x1	M 10x1 M 10x1
Dropout Width Dim, A	min. 4 mm / max. 8 mm	min. 4 mm / max. 8 mm	min. 4 mm / max. 8 mm
Holes	28 / 32 / 36	32 / 36	32 / 36
Hole diameter	3.0 mm	3.0 mm	3.0 mm
Hole ref. ø, HR	70 mm	70 mm	70 mm
Flange Dist. to 1/2 OLD	F ₁ = 27.3 mm / F ₂ = 27.6 mm	F ₁ = 27.3 mm / F ₂ = 27.6 mm	F ₁ = 27.3 mm / F ₂ = 27.6 mm
Overall	186 %	←	←
1st gear	0,734	←	←
2nd gear	1,000	←	←
3rd gear	1,362	←	←
Chainline, CL	44.0 mm (straight sprocket) / 40.5 mm (offset sprocket)	←	←
Ratio	24", 26", 28" = 2,0 – 2,4 / 20" = 2,0 – 2,5	min. 2.0	min. 2.0
Dimensions	1/2" x 1/8" and 1/2" x 3/32"	1/2" x 1/8" and 1/2" x 3/32"	1/2" x 1/8" and 1/2" x 3/32"
Sprocket	16 / 17 / 18 teeth (straight) / 19 / 20 / 21 teeth (offset)	←	←
Shifter	SRAM i-MOTION 3	SRAM i-MOTION 3	SRAM i-MOTION 3
Disc Brake	—	6 holes	—
Hand brake lever	—	Disc brake compatible	—
Tandem	Not suitable for tandems, transport bicycles or similar		←
Weight	1,390 g	1,210 g	1,120 g
Mat. Hub shell	Steel	Steel	Steel
Finish	Pearl Nickel / Chrome	Pearl Nickel / Chrome	Pearl Nickel / Chrome

i-MOTION® 3

TECHNICAL DATA / ASSEMBLY REQUIREMENTS

SHIFTERS

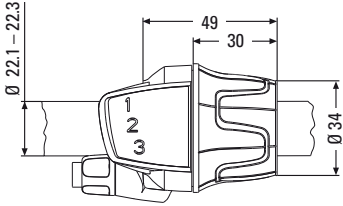

Shifter i-MOTION 3

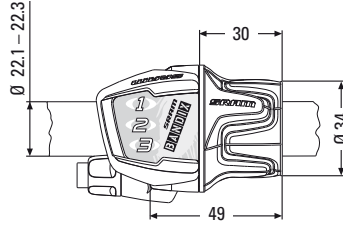

Shifter i-MOTION 3 BANDIX

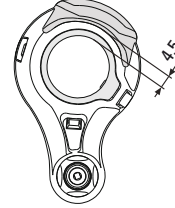

SHIFTERS

		i-MOTION 3 shifter	
		i-MOTION 3	i-MOTION 3 BANDIX (for kids)
Material	Version	i-MOTION 3	i-MOTION 3 BANDIX (for kids)
	Shift cable lengths	1400 mm / 1500 mm / 1600 mm / 1700 mm / 2200 mm	1400 mm / 1500 mm / 1600 mm / 2200 mm
	Shifter type	SRS twist shifter	SRS twist shifter
	Assembly location	Right side of handlebar	Right side of handlebar
	Compat. gear hub	i-MOTION 3	i-MOTION 3
	Gear indicator	Window	Window
	Barrel adjuster	Indexed	Indexed
	Clamping diameter	22.1 – 22.3 mm	22.1 – 22.3 mm
	Straight handlebar ends	Minimum necessary length for shifter and handlebar grip = 150 mm	
	Cable routing	Continuous cable housing (pre-assembled)	Continuous cable housing (pre-assembled)
	Weight	58 g	58 g
	Shift cable	Stainless or galvanized steel	Stainless or galvanized steel
	Housing	Plastic injection molding	Plastic injection molding
Grip cover	Thermoplastic elastomer	Thermoplastic elastomer	
Frame clamp	Aluminum	Aluminum	
Finish	Silver painted	Silver painted	

SHIFT CABLE ROUTING

- Shift cable routing only along the chain stay.
- Only continuous cable housing (no open cable routing).
- See the adjoining figure for attachment points.

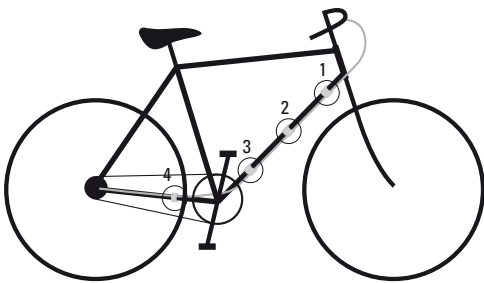

FRAME AND CHAIN GUARD

For the frame and chain guard layout, the dimensions listed below have to be considered.

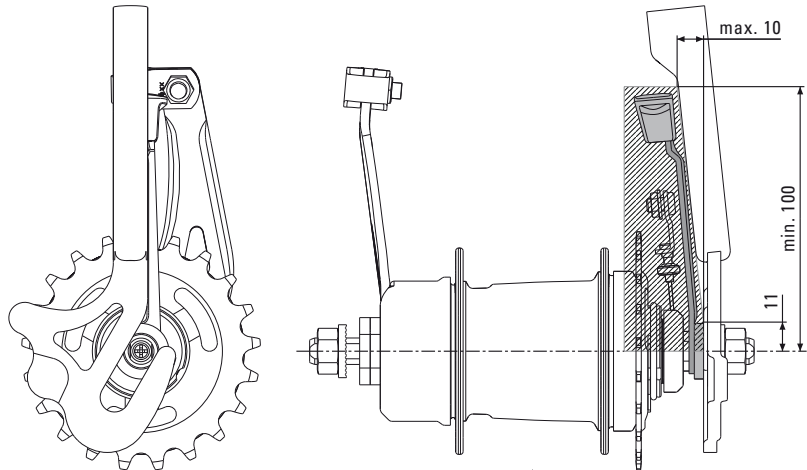

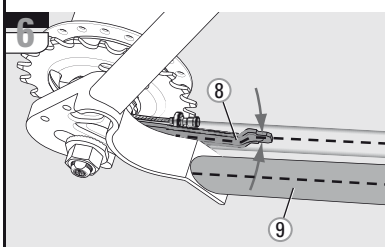
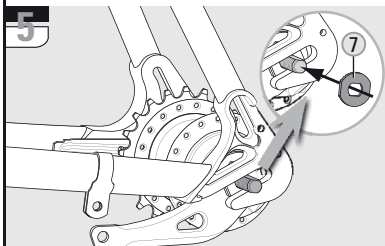
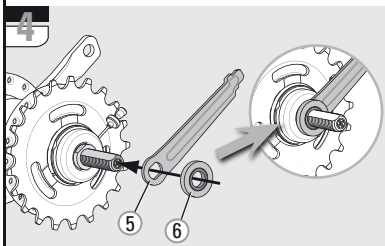
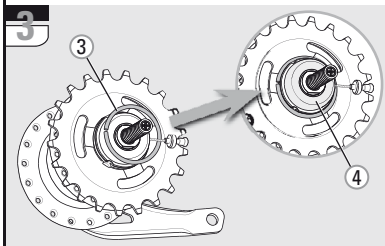
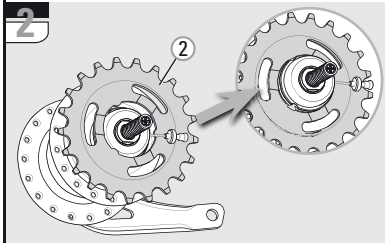
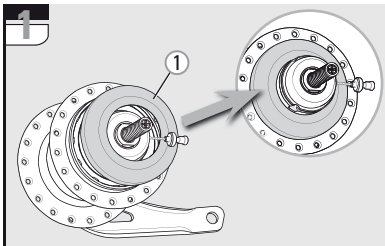

ASSEMBLING THE HUB

- » Lacing the hub:
- Lacing by hand: Place the cable stop bracket (5, figure 4) and the locking bush with the rubber insert (6) on the axle, to permit an axial spoke arrangement.
 - Automatic lacing machine: Ensure an offset of 5.5 mm. Alternatively, a spacer sleeve (part no. 0399.110.000) is mountable on the drive side of the axle.

1 Set the dust cap (1) onto the driver. The curvature must point to the outside.

2 Place the sprocket (2) on the driver. For offset, i.e. transversely displaced sprockets, the sprocket should be mounted with the toothing to the inside (the curvature must point outwards).

3 Mount the sprocket circlip (3) onto the driver.
Advice: Ensure that the plastic dust cap (4) is not damaged. Check for proper seating of the circlip.

» Hub version for Disc Brake:

Advice: Read and observe the corresponding technical documentation for assembling the disc of the disc brake.

Caution: Plane faces of the hub and the disc and the threaded holes of the hub must be clean and free from oily and greasy substances.

4 Push the cable stop bracket (5) and then the locking bush with the rubber insert (6) onto the axle end on the sprocket side.

» Place the rear wheel into the rear frame.

5 Place one retaining washer (7) on each axle end. The serrated face of the retaining washer must lie against the frame dropout.

6 Align the cable stop bracket (8) parallel to the frame strut (9).

7 Fit the axle nuts (10) and tighten these while alternating between sides. Tightening torque 30 – 40 Nm (266 – 350 in.lbs.).

8 If applicable, mount the brake lever (11) between the two straps of the frame clamp (12).

Caution: The frame clamp must be fitted tightly on the frame without any play. Use a self-locking nut (M6)! Tightening torque: 2 – 3 Nm (18 – 27 in.lbs.).

Caution: Before setting out on any ride, always check the correct and trouble-free operation of the shift system and brakes.

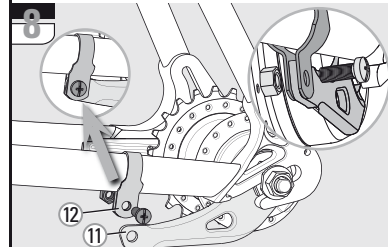
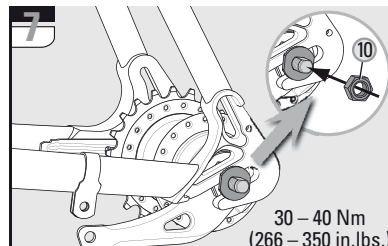

i-MOTION® 3 ASSEMBLY

FITTING THE SHIFTER

Caution: Because of a risk of fracturing, following types of handlebars are not suited:

- thin walled aluminum handlebars, e.g. Hyperlite® handlebars
- carbon handlebars

9 Slide the shifter (1) onto the handlebar.

10 Slide the handlebar grip (8) onto the handlebar.

Caution: Never use lubricants or solvents when fitting handlebar grips. They have a safety function and must not come free from the handlebar.

11 Place the shifter on the handlebar grip and position so that you can use it comfortably. Tighten the clamping bolt (3). 2.5 mm Allen wrench, torque 2 Nm (15 in.lbs.).

Caution: Check that shifter and brake lever can be easily operated (if necessary, realign).
» Never ride without handlebar grips. The turning grip of the twist shifter could become loose. This can result in severe injuries.

Caution: Before setting out on any ride, always check the correct and trouble-free operation of the shift system and brakes.

FITTING THE SHIFT CABLE

Advice: Make sure that the cable housing length is sufficient to permit turning of the handlebar over its full range.
» Also consider the influence of adjustable handlebars and stems on the cable housing length.

12 Fasten the cable housing on the frame.

Advice: The cable housing must be free to move at the securing points.
» Avoid tight bends when routing the shift cable.

13 Make sure that the shifter is set to 1st gear.

14 Make the connection between shifter and rear wheel hub by hooking the connection lug (1) onto the shift cable nipple (2).

15 Plug the plastic retainer (3) onto the cable stop bracket (4).

Caution: Before setting out on any ride, always check the correct and trouble-free operation of the shift system and brakes.

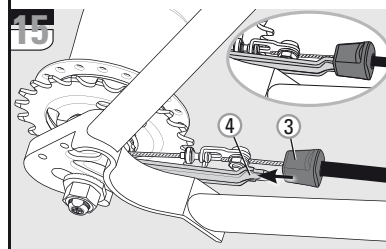
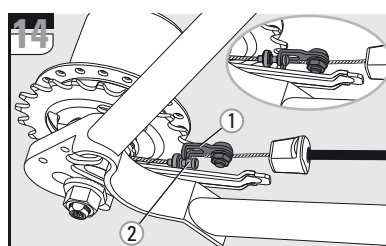
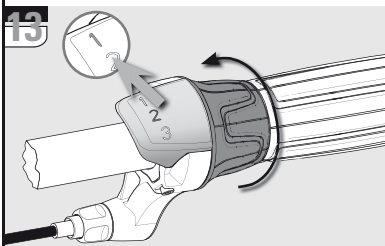
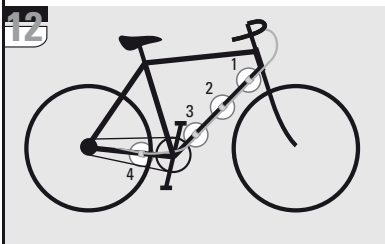
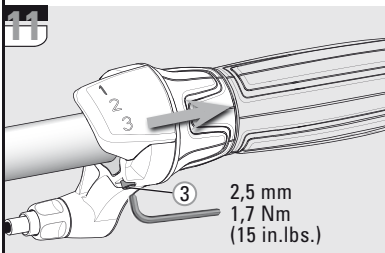
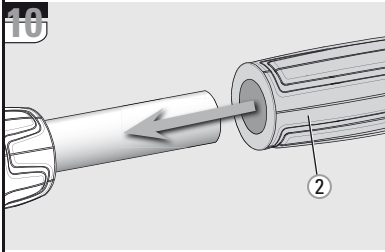
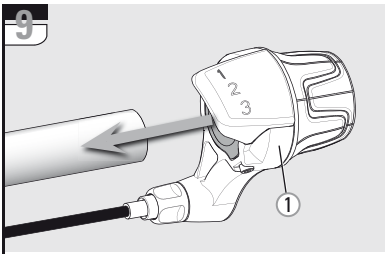

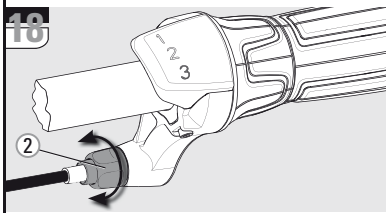
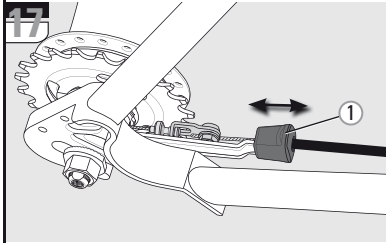
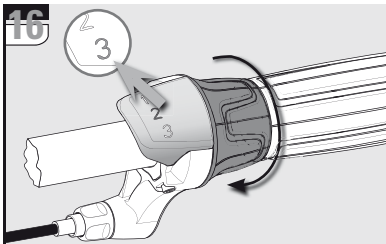

GEAR ADJUSTMENT

- » Before adjusting the gears, shift several times between 1st and 3rd gears and then back again, so that the shift cable seats itself correctly.

16 Turn the twist shifter to 3rd gear.

Advice: The shift cable should be adjusted so that it is free from play when 3rd gear is selected, i.e. it must be pulled out as far as it will go.

17 It should not be possible to pull the shift cable further out of the gear hub by pulling on the plastic retainer (1).

- Shift cable has too much play:
Turn the twist shifter to 1st gear.

18 Reduce the shift cable play by turning the barrel adjuster (2) on the shifter.

- Shift cable is too tight/taut:
Either the shifter cannot select 3rd gear or the gear hub does not shift to 1st gear or shifts constantly between 1st and 2nd gears.
Turn the twist shifter to 1st gear.

18 Reduce the shift cable tension with the aid of the barrel adjuster (2) on the shifter.

- » Turn the twist shifter to 3rd gear and check once again that there is no play in the shift cable.

i-MOTION® 3 OPERATING

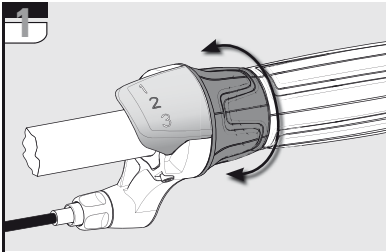

SHIFTING

- 1** Shift gears by turning the twist shifter on the right side of the handlebar.
- » You can shift gear while stationary or when riding.
 - » Ensure you shift to a lower gear in plenty of time before hills.
 - » The quickest and smoothest gear shifts are achieved by shifting while pedaling using only a low force.

BRAKING

When descending long and steep hills, always use the second (front) brake as well, to prevent overheating of the brakes.

Caution: Before setting out on any ride, always check the correct and trouble-free operation of the shift system and brakes.

Caution: Excessive heating of the hub caused by back pedal braking may result in loss of lubricant and cause sharper braking. Relubricating of the brake sleeve with special grease is then necessary. See "DISMANTLING / ASSEMBLING THE HUB", see page 36.

Advice: Read and observe the operating manual and technical documentation of the brake manufacturer.



SERVICE

To maintain optimal performance and durability of your components, periodic maintenance is required. We recommend that you have your components serviced every 2 year or 5000 km by a qualified bicycle mechanic.

CLEANING

Your SRAM i-MOTION 3 components are well protected against adverse environmental effects.

- » The rear wheel hub is not completely waterproof. However, do not use water under pressure (such as pressure washers or water jets) for cleaning to prevent malfunctions due to water penetration.
- » During the winter season, you should clean your bicycle in shorter intervals so that winter road salt cannot cause any damage.
- » Do not use aggressive cleaners.
- » Clean dirty chains before oiling. Let cleaner set for only a few minutes and rinse with water. Do not oil chain until completely dry.

LUBRICATION

- » The rear wheel hub is provided with permanent lubrication and is almost maintenance-free under normal conditions.
- » When dismantling/assembling the gear unit, observe the lubrication guidelines. See "DISMANTLING / ASSEMBLY OF THE HUB", from page 36.
- » Regular lubrication will extend the chain's service life.

REPAIR WORK

Caution: Unauthorized work on your components could endanger you and your warranty may become void.

Back pedal brake

If braking is too sharp, the brake sleeve has to be re-lubricated with special grease. See "DISMANTLING/ ASSEMBLY OF THE HUB - NON DRIVE SIDE", page 36.

WEAR PARTS

Brake liners or brake sleeve, brake cables, shift cables, handlebar grips, sprockets, and bike chains are wear parts. Please check these parts regularly and replace them well before they are worn out.

Other topics	Page
GEAR ADJUSTMENT	34
REMOVING THE REAR WHEEL	34
FITTING THE REAR WHEEL	35
EXCHANGING THE GEAR UNIT	36
DISMANTLING AND ASSEMBLING THE HUB	36
DISMANTLING AND ASSEMBLING THE GEAR UNIT	38
CHANGING THE SHIFT CABLE	46
TROUBLESHOOTING	47

i-MOTION® 3 MAINTENANCE

GEAR ADJUSTMENT

- 1 Turn the twist shifter to 3rd gear.

Advice:
The shift cable should be adjusted so that it is free from play when 3rd gear is selected, i.e. it must be pulled out as far as it will go.

- 2 It should not be possible to pull the shift cable further out of the gear hub by pulling on the plastic retainer (1).
 - Shift cable has too much play:
Turn the twist shifter to 1st gear.
 - 3 Reduce the shift cable play by turning the barrel adjuster (2) on the shifter.
 - Shift cable is too tight/taut:
Either the shifter cannot select 3rd gear or the gear hub does not shift to 1st and 2nd gears.
Turn the twist shifter to 1st gear.
 - 3 Reduce the shift cable tension with the aid of the the barrel adjuster (2) on the shifter.

» Turn the twist shifter to 3rd gear and check once again that there is no play in the shift cable.

REMOVING THE REAR WHEEL

- 4 Turn the twist shifter to 1st gear.
- 5 Pull the plastic retainer (1) from the cable stop bracket (2).
- 6 Break the connection between shifter and rear wheel hub by unhooking the connection lug (3) from the shift cable nipple (4).
- 7 Loosen the axle nuts (5) before removing them together with the underlying retaining washers (6).
If applicable, remove the brake lever screw (7) from the frame clip.

» Remove the rear wheel.

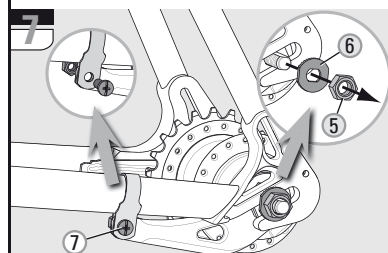
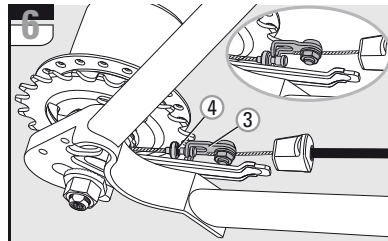
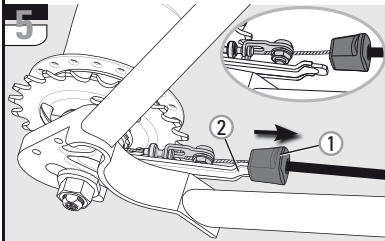
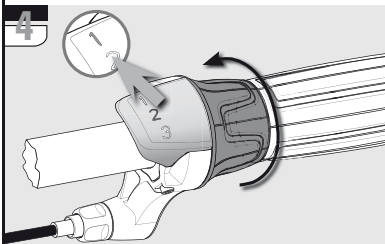
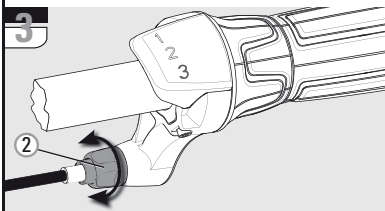
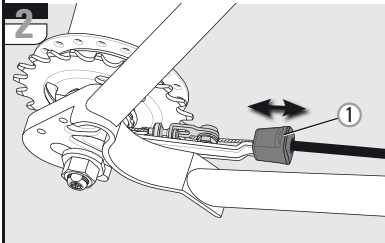
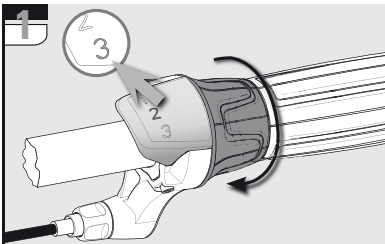

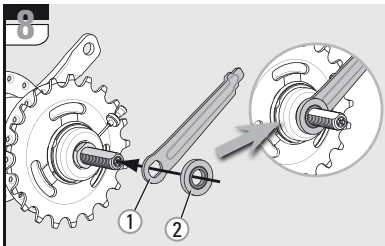

FITTING THE REAR WHEEL

8 If dismantled, push the cable stop bracket (1) and then the locking bush with the rubber insert (2) onto the axle end on the sprocket side.

» Place the rear wheel into the rear frame.

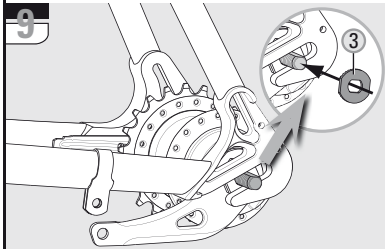

9 Place one retaining washer (3) on each axle end. The serrated face of the retaining washer must lie against the frame dropout.

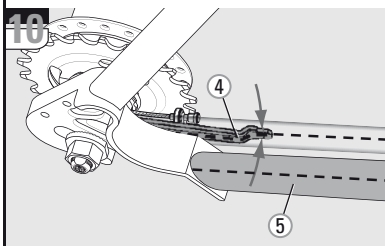

10 Align the cable stop bracket (4) parallel to the frame strut (5).

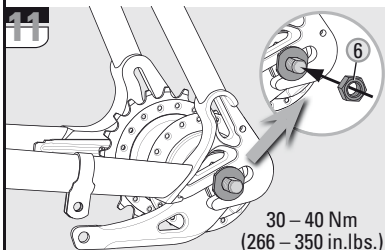

11 Fit the axle nuts (6) and tighten these while alternating between sides. Tightening torque 30 – 40 Nm (266 – 350 in.lbs.).

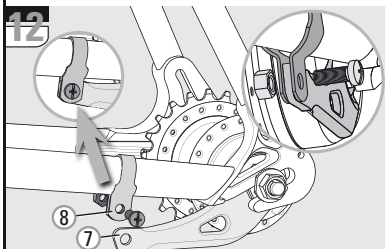

12 If applicable, mount the brake lever (7) between the two straps of the frame clamp (8).

Caution: The frame clamp must be fitted tightly on the frame without any play. Use a self-locking nut (M6)! Tightening torque: 2 – 3 Nm (18 – 27 in.lbs.).

13 Make sure that the shifter is set to 1st gear.

14 Make the connection between shifter and rear wheel hub by hooking the connection lug (9) onto the shift cable nipple (10).

15 Plug the plastic retainer (11) onto the cable stop bracket (12).

Caution: Before setting out on any ride, always check the correct and trouble-free operation of the shift system and brakes.

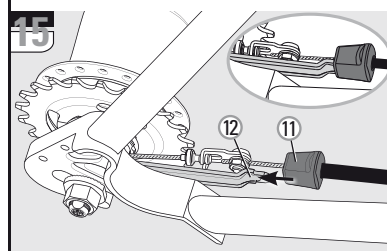
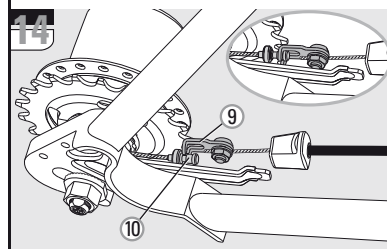
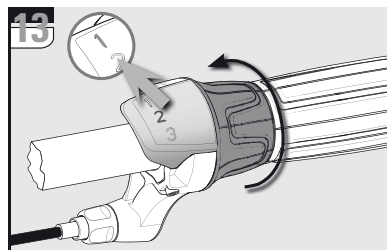

i-MOTION® 3 MAINTENANCE

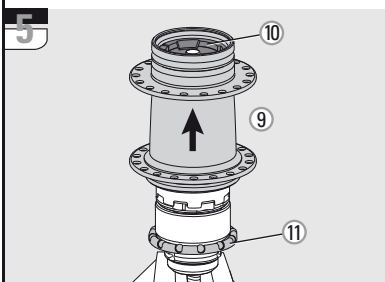
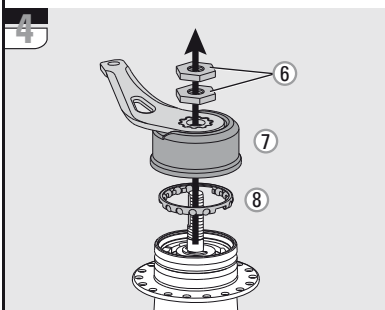
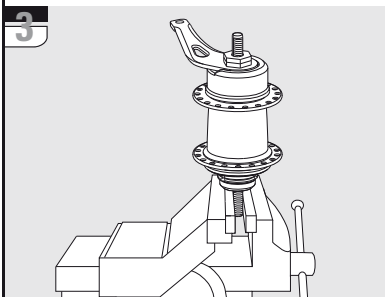
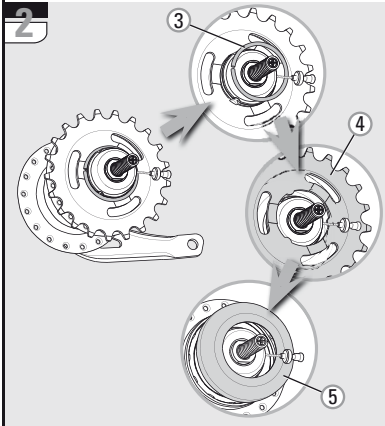
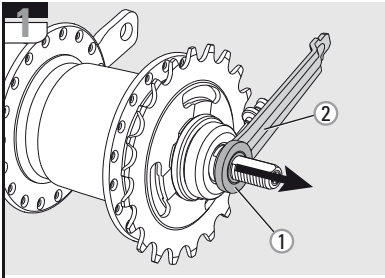

EXCHANGING THE GEAR UNIT / WORKING ON THE BACK PEDAL BRAKE

DISMANTLING THE HUB

Work on the brake cone / adjusting cone and ball retainer of the non-drive side:

1 Take off the locking bush (1) and the cable stop bracket (2).

2 Detach the circlip (3).
Caution: The circlip is spring force loaded. Take off the sprocket (4) and the dust cap (5).

3 Clamp the drive side of the axle with the two flats of the axle in a vise.

4 Unscrew both nuts (6) from the axle. Wrench size 22 mm.

For the no-brake hub version, the locknut and the underlying adjusting cone should be unscrewed from the axle. Wrench size 17 mm.

4 Hub version with back pedal brake: Take off the lever cone (7) and the ball retainer (8).

» Lubrication and assembly details can be found in the following column.

Work on the brake segments (hub version with back pedal brake) and ball retainer on the drive side:

» Dismantle the hub as previously described ("Work on brake cone / adjusting cone and ball retainer on non-drive side").

5 Take the hub shell (9) off in an upwards direction. Take both brake segments (10) out of the hub shell. Take off the ball retainer (11) in an upwards direction.

Advice: When exchanging the gear unit, removal of the ball retainer is not necessary.

» Lubrication and assembly details can be found in the following column.

ASSEMBLING THE HUB

For a gear unit change:

Clamp the new gear unit on the drive side of the axle in the vise.

Clean the parts after dismantling:

The parts can be degreased in a cleaning bath.

Lubricating the parts:

Caution: Use only SRAM special grease, part no. 0369 135 200 / ... 201 and commercially available cycle oil. Lubricate ball retainers and ball tracks only with SRAM Ball Bearing Grease. Part no. 0369.001.015

Work on the brake segments (hub version with back pedal brake) and ball retainer on the drive side:

Lubrication: Grease the ball track (12) of the driver and the ball retainer (13) with SRAM Ball Bearing Grease (part no. 0369.001.015).

6 Insert the ball retainer (13) with the balls pointing upwards towards the driver (12).

Lubrication: Oil both pawls (15) of the planetary gear carrier.
6 For the hub version with back pedal brake, place a drop of oil on the 5 rollers (14).

7 Lightly grease the inside of the hubshell with SRAM special grease. Lightly grease the ball tracks (17) with SRAM Ball Bearing Grease (part no. 0369.001.015). For the hub version with back pedal brake lightly grease the brake cylinder (16).

Caution: Use only SRAM special grease, part no. 0369 135 200 / ... 201.

7 Position the hub shell. Turning slightly to the left/right eases positioning. Ensure that the hub shell is correctly seated on the ball retainer (18).

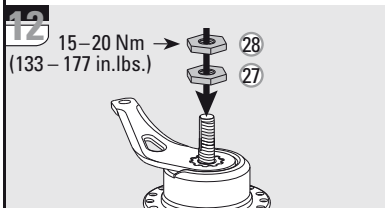
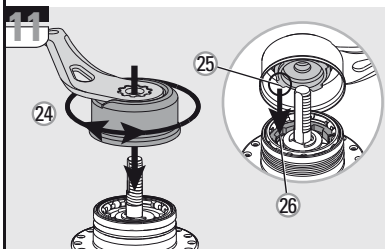
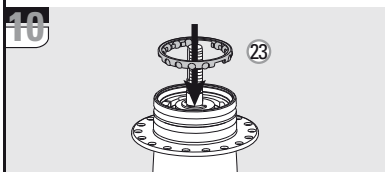
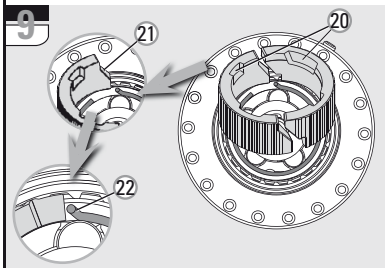
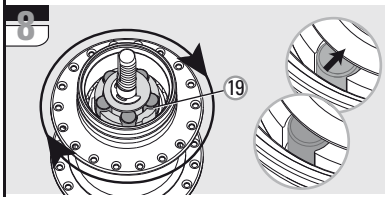
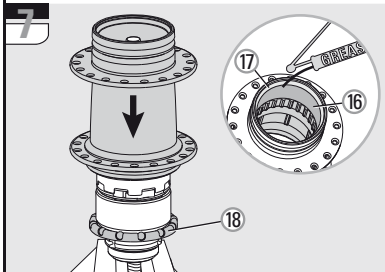
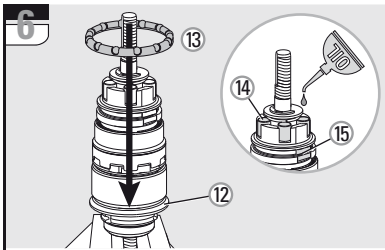

6 Hub version with back pedal brake:
Turn the shell in a clockwise direction as far as it will go. This ensures that the rollers (19) of the brake can fall back and that the brake segments can be mounted.

» Hub version with back pedal brake:
Lubrication:
Clean the brake segments and completely coat the outer surfaces with grease.

Caution:
Use only SRAM special grease, part no. 0369 135 200 / ... 201.

9 Inserting the brake segments:
The recesses (20) must point upwards.

» At first insert the brake segment so that the bevel (21) is visible from above.

Advice:
The brake segment lie against the angled spring end (22).

» Insert the second brake segment.

Advice:
The brake segments must be renewed, if, as a result of wear, the grooves on the outer surface are scarcely visible.

Work on the brake cone / adjusting cone and ball retainer of the non-drive side:

Lubrication:
Clean the ball retainer (23) and grease it using SRAM Ball Bearing Grease (part no. 0369.001.015).

10 Insert the ball retainer (23). The side with the balls must point downwards.

11 Hub version with back pedal brake:
Fit the lever cone (24).
By turning to the left and right, bring the lever cone (24) into its final position. The locating lugs (25) of the lever cone will then lie in the recesses (26) of the brake segments.

12 Screw an axle nut (27) onto the axle.
Wrench size 22 mm.

» Hub versions without brakes and i-BRAKE:
screw the adjusting cone onto the axle.
Wrench size 17 mm.

12 Position the bearing in a play-free manner and tighten using nut (28).
Wrench size 22 mm. Tightening torque 15 – 20 Nm (133 – 177 in.lbs.).
Test the play of the bearing and correct if required.

» Clamp the hub with the other axle side in the vise.

13 Set the dust cap (29) onto the driver.
The curvature must point to the outside.

14 Place the sprocket (30) on the driver.
For offset, i.e. transversely displaced sprockets, the sprocket should be mounted with the toothing to the inside (the curvature must point outwards).

15 Mount the sprocket circlip (31) onto the driver.

Advice:
Ensure that the plastic protective cap (32) is not damaged.
Check for proper seating of the circlip.

» Remove the hub from the vise.

» Fit the rear wheel into the rear frame as described on page 35.
Adjust the gears as described on page 34.

Caution:
Before setting out on any ride, always check the correct and trouble-free operation of the shift system and brakes.

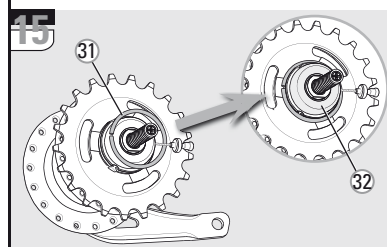
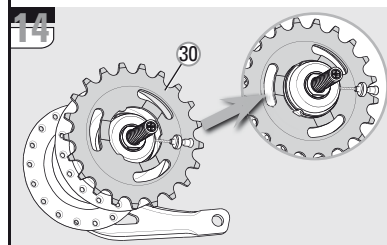
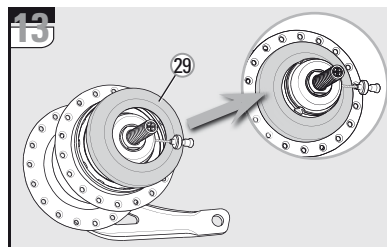

i-MOTION® 3 MAINTENANCE

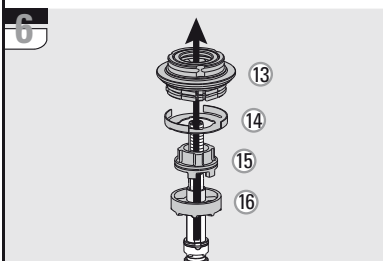
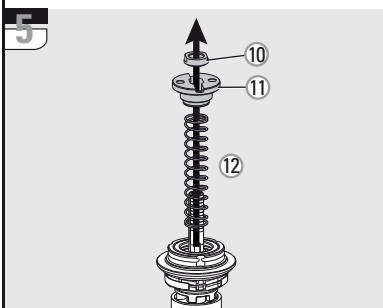
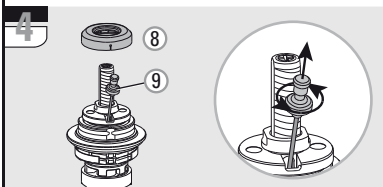
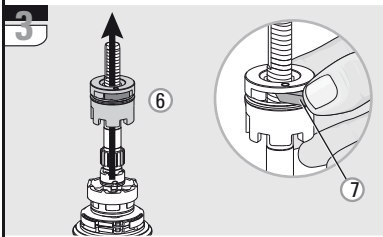
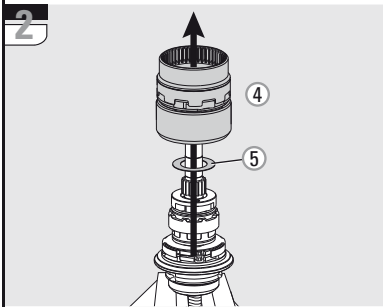
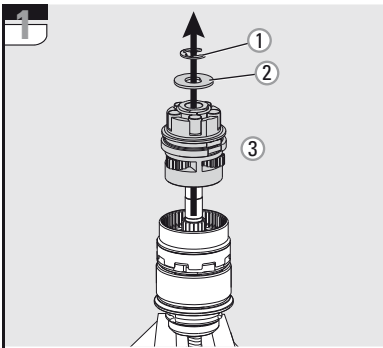

DISMANTLING THE GEAR UNIT

Gear hubs until July 2007 (Gear hubs as of August 2007 see page 42)

Remove the gear unit as described on page 36.

1 Remove the retaining ring (1) and take off the washer (2) and planetary gear carrier (3) beneath it.

2 Take off the ring gear (4) and washer (5).

3 Take off the pawl carrier (6).

Advice: Press on the pawls (7) to make removal easier.

» Clamp the hub with the other axle side in the vise.

4 Take off the plastic protective cap (8). Undo the shift cable (9) by turning in an anticlockwise direction and pull it out of the axle.

5 Unscrew the threaded bushing (10) from the axle. Wrench size 13 mm. Take off the fixed cone (11) and spring (12) from the axle.

6 Hub version with back pedal brake: Take off the driver (13) and the control washer (14) beneath it. Take off the coupling piece (15) and shift bush (16).

Work on the thrust block:

Advice: The thrust block only requires attention if the shift cable has torn off.

7 Unscrew the red grub screw (17) from the axle.

Caution: The grub screw is spring force loaded.

Take the spring (18) and spacer bolt (19) out of the axle.

7 Turn the circlip (20) and take the thrust block (21) out of the axle.

» Lubrication and assembly details can be found on the following page.

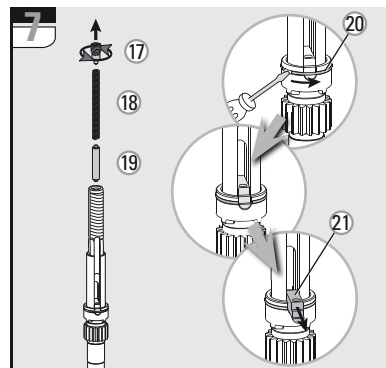

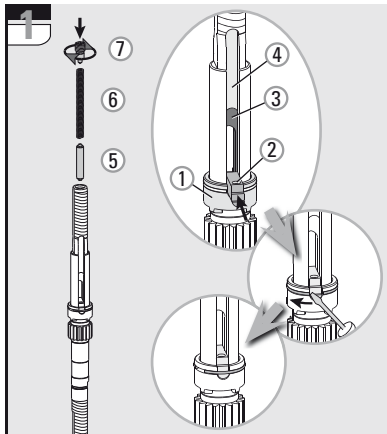

ASSEMBLING THE GEAR UNIT Gear hubs until July 2007 (Gear hubs as of August 2007 see page 43)

Clean the parts after dismantling:

Caution: The planetary gear carrier and the driver should only be cleaned on the outside using a paint brush so that they are not degreased. Cleaning in a cleaning bath is not permitted.

The remaining parts can be degreased in a cleaning bath.

Lubricating the parts:

Caution: Use only SRAM special grease, part no. 0369 135 200 / ... 201. Lubricate ball retainers and ball tracks only with SRAM Ball Bearing Grease. Part no. 0369.001.015.

Work on the thrust block / assembly of the axle:

1 Place the thrust block in the shift sleeve (1).

Advice: The tapped hole (2) of the thrust block must be located on the axle side with the long slit (3). This subsequently allows the shift cable to run through the long slit (4).

Turn the circlip through 90 degrees to secure the thrust block.

1 Insert the spacer bolt (5) and spring (6) in the axle. Turn the red grub screw (7) so it is flush with the axle.

Assembling the gear unit:

Lubrication: Lightly grease the axle and grease the tothing (8). Use only SRAM special grease, part no. 0369 135 200 / ... 201. Place a drop of oil on the thrust block (9).

2 Fit the shift bush (10) with the crown tothing (11) facing downwards towards the axle. Place the coupling piece (12) with the lugs (13) downwards on to the shift bush.

3 Hub version with back pedal brake: Place the control washer (14) with the bent up ends (15) facing upwards on the coupling piece (16).

» Hub version without brake: Place the large washer on the coupling piece.

Lubrication: Oil the 4 pockets for the pawls (17) and the driver pawl spring (18).

4 Grease the ball retainer (19) with SRAM Ball Bearing Grease (part no. 0369.001.015).

5 Seat the driver (20) on the control washer (21). The pawls (22) must lie in the recesses of the control washer.

6 Push the spring (23) and the fixed cone (24) onto the axle. Fit the threaded bushing (25) and tighten with a torque of 15 – 20 Nm (133 – 177 in.lbs.). Wrench size 13 mm.

Lubrication: On the axle side with the recess (26) for the shift cable, the opening (27) on the fixed cone must be filled with grease. Use only SRAM special grease, part no. 0369 135 200 / ... 201.

8 Push the shift cable on the side of the recess (28) into the fixed cone and secure it, by turning in a clockwise direction (minimum of 7 full turns). Turn only until hand-tight.

9 Fit the plastic protective cap (29).

» Clamp the hub with the other axle side in the vise.

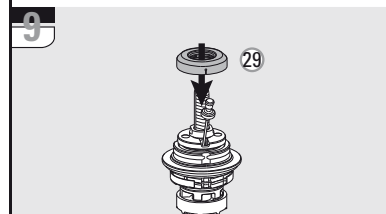
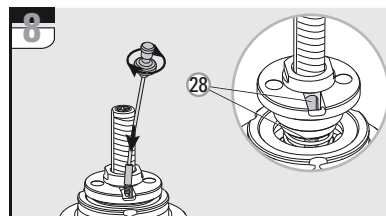
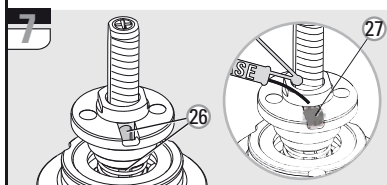
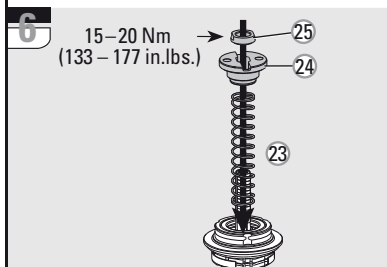
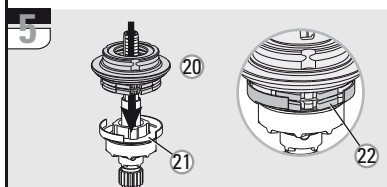
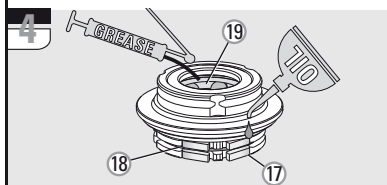
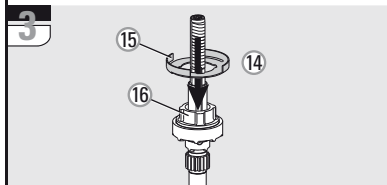
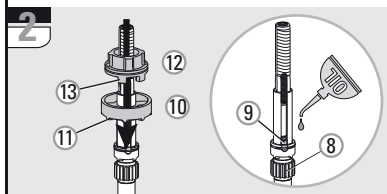

i-MOTION® 3 MAINTENANCE

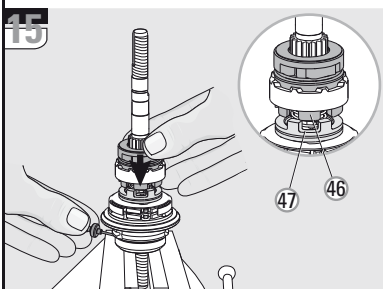
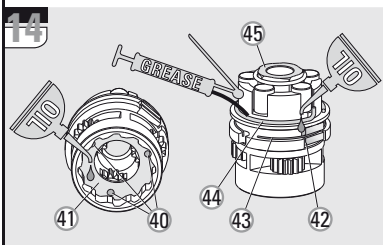
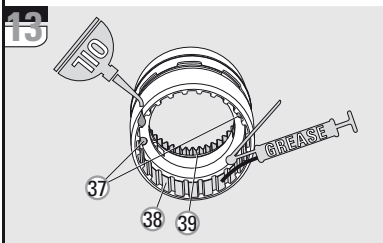
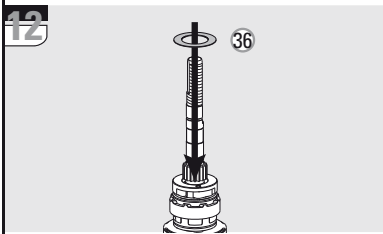
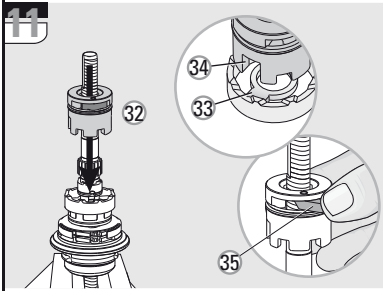
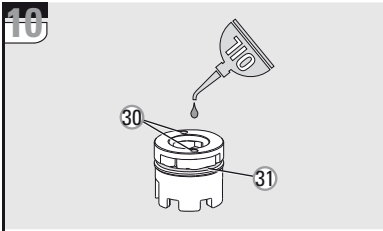



Lubrication:
 Apply a drop of oil on both bearing bolts (30) of the pawl carrier. Oil the pawl spring (31).

11 Insert the pawl carrier (32) in the shift bush. The leg (33) of the shift bush lies in the two large recesses (34) of the pawl carrier.

Advice:
 Press on the pawls (35) to make insertion easier.

12 Place the washer (36) on the pawl carrier.

Lubrication:
 Apply a drop of oil to both bearing bolts (37) of the ring gear.
13 Apply a little grease to the pawl teeth (38) and grease the ring gear teeth (39). Use only SRAM special grease, part no. 0369 135 200 / ... 201.

Lubrication:
 Apply a drop of oil on the three bearing bolts (40) of the planetary gear carrier and oil the contact surface (41). Oil the pawl pockets (42) and the pawl spring (43). Grease the seat of the friction spring (44) with SRAM special grease, part no. 0369 135 200 / ... 201. Oil the end surface (45).

15 Match the profile of the pawl carrier (46) to that of the coupling piece (47). Press the pawl carrier down, pull on the shift cable and hold the system in this position for the next work step.

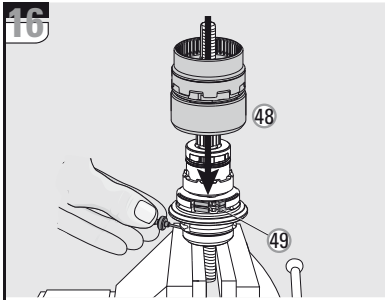

16 Fit, while holding the system in position, the larger diameter ring gear (48) downwards over the pawls (49) of the driver.
Maintain the system in this position.

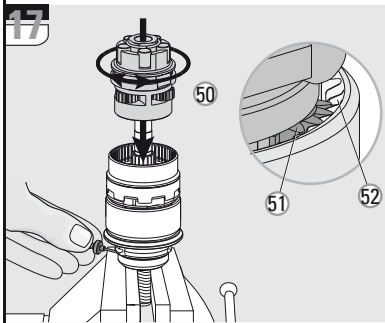

17 Mount the planetary gear carrier (50).
By turning to the left and right, bring the planetary gear carrier into its final position.

Advice:
The planetary gears (51) must be flush with the ring gear teeth (52).
Maintain the system in this position.

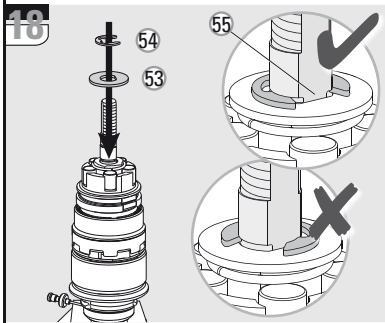

18 Position the washer (53) and fit the circlip (54).
Caution:
The opening of the circlip must be located over the axle flat (55).

» Complete hub assembly as described on page 36 under "ASSEMBLING THE HUB".

i-MOTION® 3 MAINTENANCE

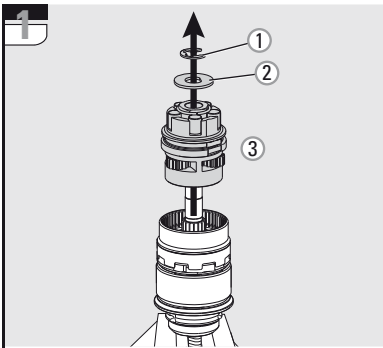

DISMANTLING THE GEAR UNIT

Gear hubs as of August 2007
(Gear hubs until July 2007 see page 38)

Remove the gear unit as described on page 36.

1 Remove the retaining ring (1) and take off the washer (2) and planetary gear carrier (3) beneath it.

2 Take off the ring gear (4) and washer (5).

3 Take off the pawl carrier (6).

Advice:
Press on the pawls (7) to make removal easier.

» Clamp the hub with the other axle side in the vise.

4 Take off the plastic protective cap (8). Undo the shift cable (9) by turning in an anticlockwise direction and pull it out of the axle.

5 Loosen the threaded bushing (10), but leave it on the axle with a couple of threads. Wrench size 13 mm. Lift the driver off one time to release the inboard spacer sleeve. Take off the threaded bushing (10), the cable guide bush (11), the spacer sleeve (12), the fixed cone (13), and spring (14) from the axle.

6 Hub version with back pedal brake: Take off the driver (15) and the control washer (16) beneath it. Take off the coupling piece (17) and shift bush (18).

6 Hub version without brake: Take off the driver (15) and the control washer (16) beneath it. Take off the coupling piece (17) and shift bush (18).

Work on the thrust block:

Advice:
The thrust block only requires attention if the shift cable has torn off.

7 Unscrew the red grub screw (19) from the axle.

Caution:
The grub screw is spring force loaded.

Take the spring (20) and spacer bolt (21) out of the axle.

7 Turn the circlip (22) and take the thrust block (23) out of the axle.

» Lubrication and assembly details can be found on the following page.

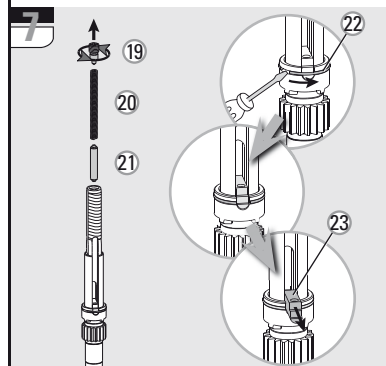
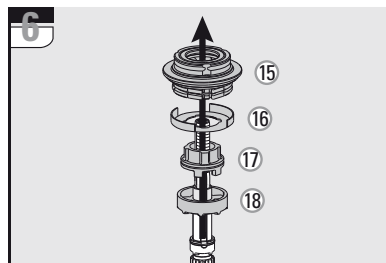
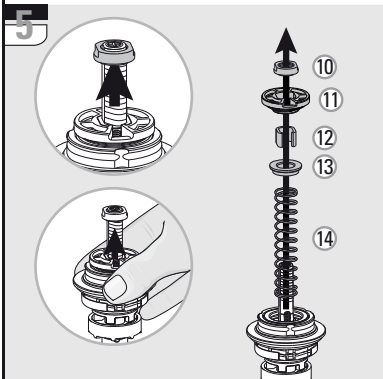
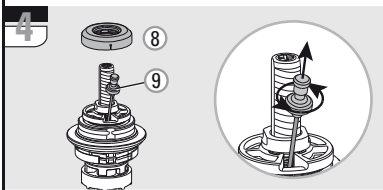
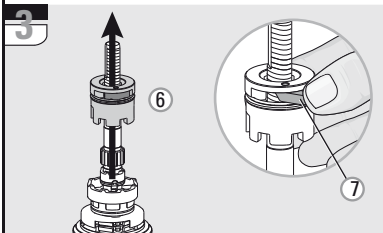
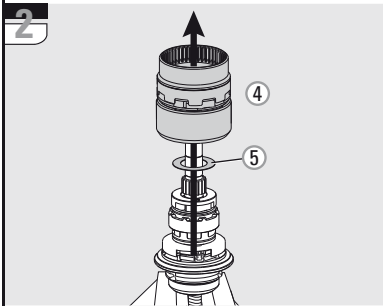

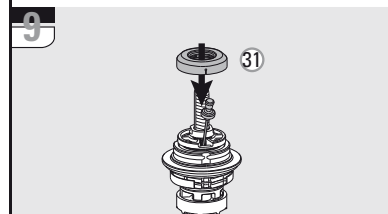
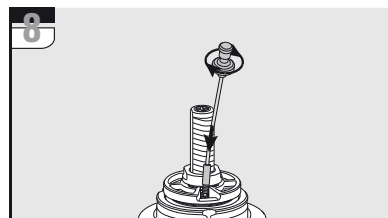
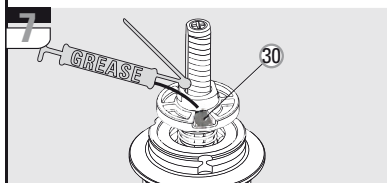
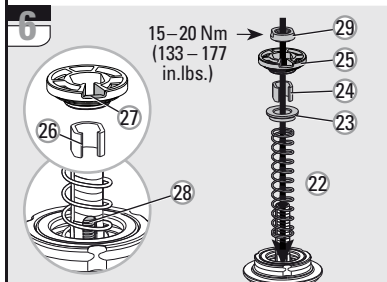
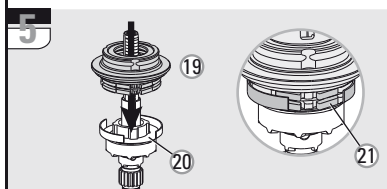
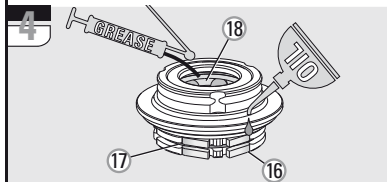
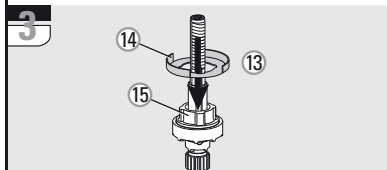
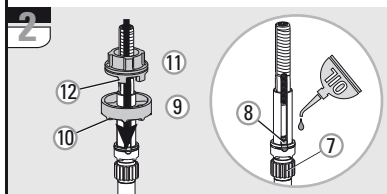
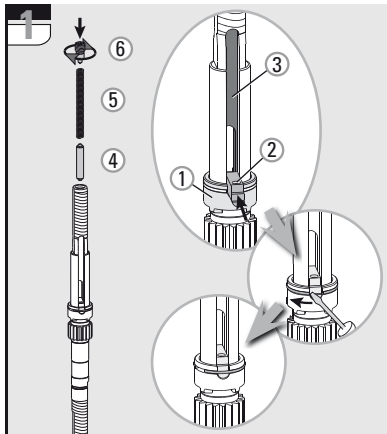

ASSEMBLING THE GEAR UNIT

Gear hubs as of August 2007
(Gear hubs until July 2007 see page 39)

Clean the parts after dismantling:

Caution: The planetary gear carrier and the driver should only be cleaned on the outside using a paint brush so that they are not degreased. Cleaning in a cleaning bath is not permitted.

The remaining parts can be degreased in a cleaning bath.

Lubricating the parts:

Caution: Use only SRAM special grease, part no. 0369 135 200 / ... 201. Lubricate ball retainers and ball tracks only with SRAM Ball Bearing Grease. Part no. 0369.001.015.

Work on the thrust block / assembly of the axle:

1 Place the thrust block in the shift sleeve (1).

Advice: The tapped hole (2) of the thrust block must be located on the axle side with the long slit (3). This subsequently allows the shift cable to run through the long slit.

Turn the circlip through 90 degrees to secure the thrust block.

1 Insert the spacer bolt (4) and spring (5) in the axle. Turn the red grub screw (6) so it is flush with the axle.

Assembling the gear unit:

Lubrication: Lightly grease the axle and grease the tooting (7). Use only SRAM special grease, part no. 0369 135 200 / ... 201. Place a drop of oil on the thrust block (8).

2 Fit the shift bush (9) with the crown tooting (10) facing downwards towards the axle. Place the coupling piece (11) with the lugs (12) downwards on to the shift bush.

3 Hub version with back pedal brake: Place the control washer (13) with the bent up ends (14) facing upwards on the coupling piece (15).

» Hub version without brake: Place the large washer on the coupling piece.

Lubrication: Oil the 4 pockets for the pawls (16) and the driver pawl spring (17).

4 Grease the ball retainer (18) with SRAM Ball Bearing Grease (part no. 0369.001.015).

5 Seat the driver (19) on the control washer (20). The pawls (21) must lie in the recesses of the control washer.

6 Push the spring (22), the fixed cone (23), the spacer sleeve (24), and the cable guide bush (25) onto the axle.

Advice: The slotted side (26) of the spacer sleeve and the guide surface (27) of the cable guide bush must be located on the axle side with the slit (28) for the shift cable.

Fit the threaded bushing (29) and tighten with a torque of 15 – 20 Nm (133 – 177 in.lbs.). Wrench size 13 mm.

Lubrication: Fill the opening (30) for the shift cable on the cable guide bush with grease. Use only SRAM special grease, part no. 0369 135 200 / ... 201.

8 Push the shift cable into the cable guide bush and secure it, by turning in a clockwise direction (minimum of 7 full turns). Turn only until hand-tight.

9 Fit the plastic protective cap (31).

» Clamp the hub with the other axle side in the vise.

i-MOTION® 3 MAINTENANCE

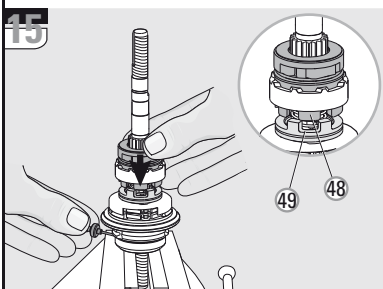
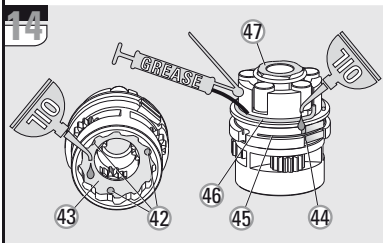
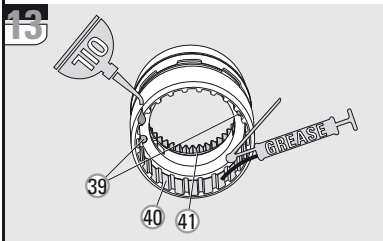
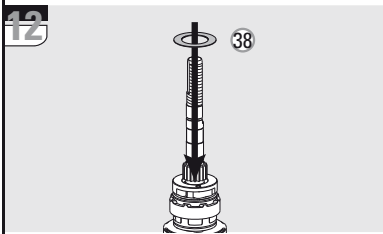
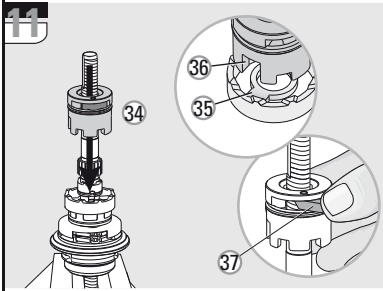
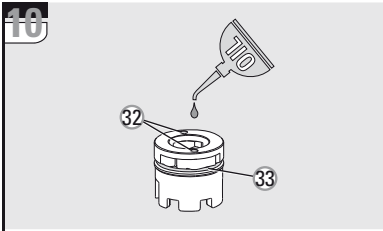



Lubrication:
 Apply a drop of oil on both bearing bolts (32) of the pawl carrier. Oil the pawl spring (33).

11 Insert the pawl carrier (34) in the shift bush. The leg (35) of the shift bush lies in the two large recesses (36) of the pawl carrier.

Advice:
 Press on the pawls (37) to make insertion easier.

12 Place the washer (38) on the pawl carrier.

Lubrication:
 Apply a drop of oil to both bearing bolts (39) of the ring gear.
13 Apply a little grease to the pawl teeth (40) and grease the ring gear teeth (40). Use only SRAM special grease, part no. 0369 135 200 / ... 201.

Lubrication:
 Apply a drop of oil on the three bearing bolts (42) of the planetary gear carrier and oil the contact surface (43). Oil the pawl pockets (44) and the pawl spring (45). Grease the seat of the friction spring (46) with SRAM special grease, part no. 0369 135 200 / ... 201. Oil the end surface (47).

15 Match the profile of the pawl carrier (48) to that of the coupling piece (49). Press the pawl carrier down, pull on the shift cable and hold the system in this position for the next work step.

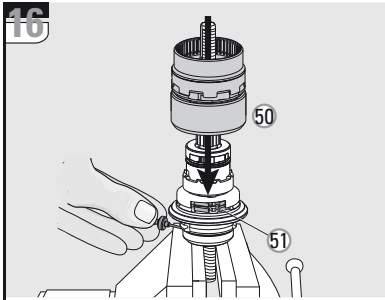

16 Fit, while holding the system in position, the larger diameter ring gear (50) downwards over the pawls (51) of the driver.
Maintain the system in this position.

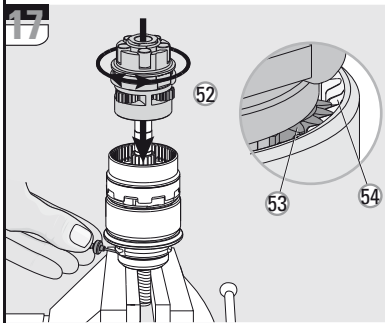

17 Mount the planetary gear carrier (52).
By turning to the left and right, bring the planetary gear carrier into its final position.

Advice:
The planetary gears (53) must be flush with the ring gear teeth (54).
Maintain the system in this position.



18 Position the washer (55) and fit the circlip (56).
Caution:
The opening of the circlip must be located over the axle flat (57).

» Complete hub assembly as described on page 36 under "ASSEMBLING THE HUB".

i-MOTION® 3 MAINTENANCE

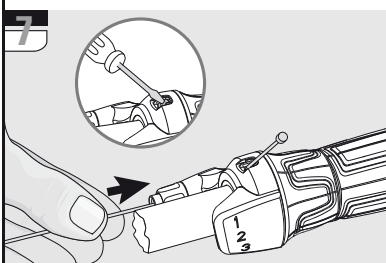
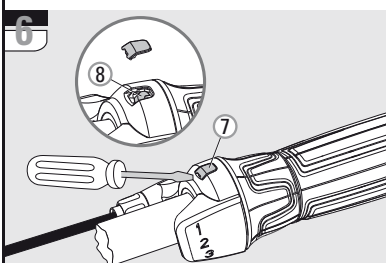
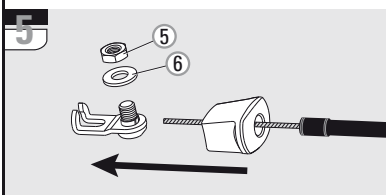
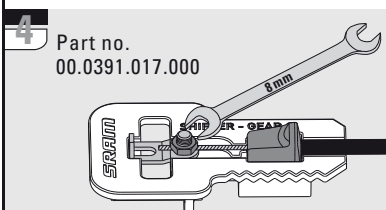
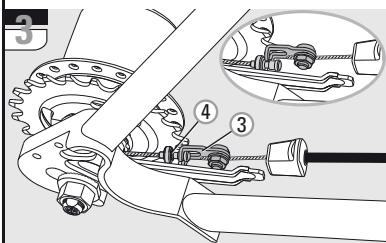
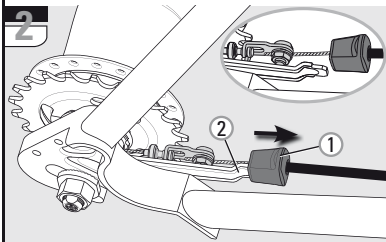
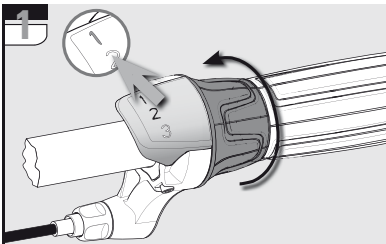

CHANGING THE SHIFT CABLE

Advice:
Always use new, high-quality cables and compressionless cable housings with end caps.

1 Turn the twist shifter to 1st gear.

2 Pull the plastic retainer (1) from the cable stop bracket (2).

3 Break the connection between shifter and rear wheel hub by unhooking the connection lug (3) from the shift cable nipple (4).

4 Place the plastic retainer and the connection lug in the assembly tool (SRAM part no. 00.0391.017.000). Unscrew the nut (wrench size 8 mm).

Advice:
You may want to clamp the assembly tool in a vise.

5 Take the nut (5) and the underlying washer (6) off. Take off the connection lug and the plastic retainer from the shift cable.

1 Make sure that the shifter is set to 1st gear.

6 Remove the cap (7) from the shifter. The nipple (8) of the inner cable is now visible.

7 Push or pull the old inner cable out of the shifter, e.g. using a small screwdriver.

» Guide the new inner cable into the cable inlet, through the shifter and the new cable housing. Pull the cable tight.

» Insert the cap in the shifter.

8 Screw in the shifter barrel adjuster (9) at the shifter in a clockwise direction as far as it will go, then turn counterclockwise 2 full turns.

Fitting the connection lug with assembly tool (SRAM part no. 00.0391.017.000):

Advice:
You may want to clamp the assembly tool in a vise.

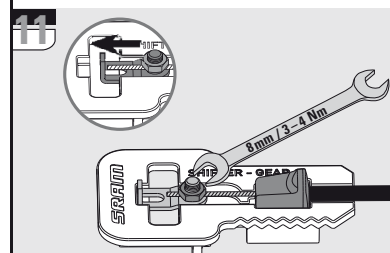
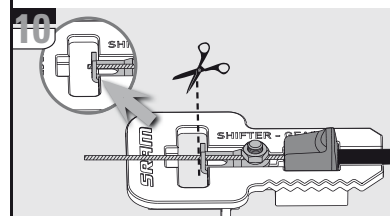
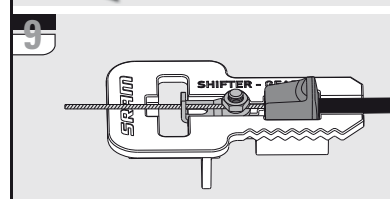
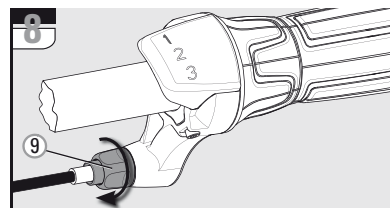

9 Push the plastic retainer and the connection lug with fitted washer and nut onto the inner cable. Place the plastic retainer and the connection lug in the assembly tool.

10 Pull the inner cable tight and cut it off directly at the connection lug.

11 Push the connection lug to the left and tighten the nut. Tightening torque: 3 – 4 Nm (27 – 35 in.lbs). Wrench size 8 mm.

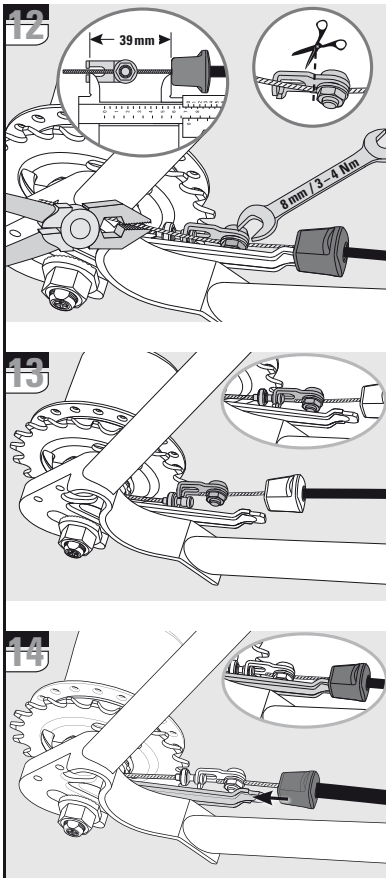

Fitting the connection lug without an assembly tool:

12 Push the plastic retainer and the connection lug with fitted washer and nut onto the inner cable. Fit the plastic retainer on the cable stop bracket. Hook the connection lug onto the hub shift cable nipple. Pull the inner cable tight and securely tighten the nut of the connection lug. Unhook the connection lug again and cut off the projecting excess cable so it is as short as possible.

13 Make the connection between shifter and rear wheel hub by hooking the connection lug onto the shift cable nipple.

14 Plug the plastic retainer onto the cable stop bracket.

» Adjust the gears as described on page 34.

Caution: Before setting out on any ride, always check the correct and trouble-free operation of the shift system and brakes.

TROUBLESHOOTING

Problem	Cause	Remedy
Shifting difficulties:	Incorrect gear adjustment.	Adjust the gears. Page 34.
	The shift cable or the cable housing is damaged.	Renew the shift cable and cable housing. Page 46.
	Shift cable of the hub is not screwed in completely.	Screw in completely the shift cable of the hub (minimum of 7 full turns). Page 39 or 43 figure 8. Turn only until hand-tight!
The pedals go forwards when freewheeling:	The chain tension is too tight.	Slacken the chain tension.
	The bearing adjustment is too tight.	Readjust the bearing. Page 37.
	Locknut of the lever cone / adjusting cone is loose.	Readjust the bearing and tighten the locknut. Page 37, figure 12, no. 28.
The back pedal brake is too sharp or locked:	The brake segments are no longer lubricated.	Lubricate the brake cylinder of the hub shell and the brake segments (if necessary renew). Page 36, "Work on the brake segments".

SRAM® TORPEDO® SINGLESPEED TECHNICAL DATA / ASSEMBLY REQUIREMENTS



DROPOUTS

- Dropout thickness:
130 mm Over Locknut Dimension: 5 – 12 mm.
120 mm Over Locknut Dimension: 8 – 12 mm.
- Dropouts must be parallel.
- Slot width at rear dropout: max. $10^{+0.5}$ mm.

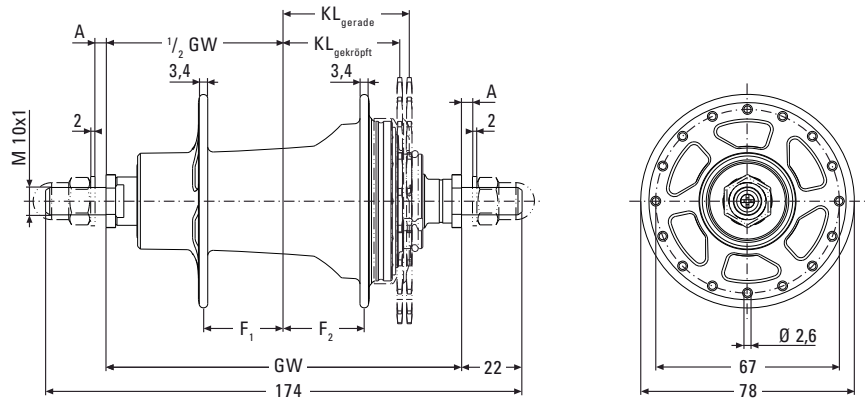

TORPEDO

		Torpedo Singlespeed NEW	
	Speeds	Singlespeed, fixed gear / Singlespeed, freewheel	←
	Brake	Without brake	←
	Over Locknut Dim., OLD	130 mm	120 mm
	Length	174 mm	←
Axle	Ends Diameter	M 10x1	←
	Dropout Width Dim, A	min. 5 mm / max. 12 mm	min. 8 mm / max. 12 mm
Spoke	Holes	32	←
	Hole Diameter	2.6 mm	←
	Hole Reference ø	67 mm	←
	Flange Dist. to 1/2 OLD	$F_1 = 29.5$ mm / $F_2 = 29.5$ mm	←
Chain	Chainline, CL	46 mm (straight sprocket) / 42.5 mm (offset sprocket)	←
	Dimensions	$\frac{1}{2}'' \times \frac{1}{8}''$ and $\frac{1}{2}'' \times \frac{3}{32}''$	←
Compat.	Sprocket	16 / 17 / 18 teeth (straight) / 19 / 20 / 21 teeth (offset)	←
	Tandem	Not suitable for tandems, transport bicycles or similar	←
	Weight	480 g	←
Finish	Material Hub Shell	Forged Alloy	←
	Finish	Anodised silver / Anodised black	←

SRAM® TORPEDO® SINGLESPEED ASSEMBLY

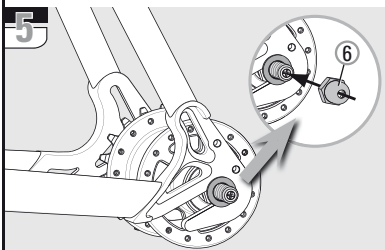
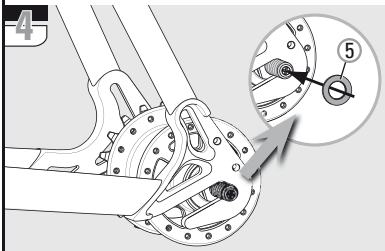
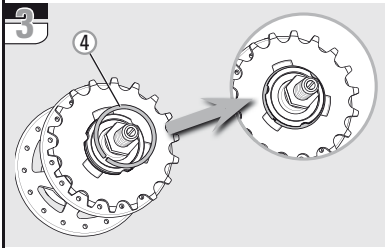
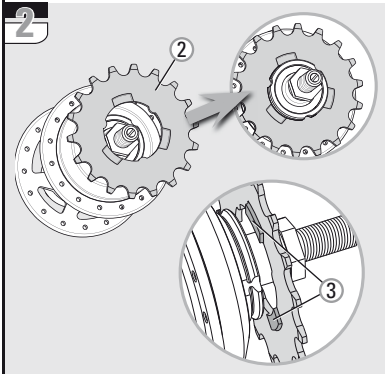
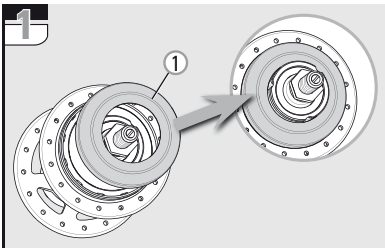

ASSEMBLY HUB

» Spoke the hub as normal.

5 Set the dust cover (1) onto the driver.

6 Set the sprocket (2) onto the driver.



Advice:

When fitting a straight sprocket (not an offset version), the beading (3) of the sprocket must lie against the dust cover.

7 Mount the sprocket retaining ring (4) onto the driver. Check proper seat of the retaining ring.

» Place the chain on the sprocket. Place the rear wheel into the rear frame and align it.

8 Slide one retaining washer (5) onto each axle end.

9 Mount the axle nuts (6) and tighten them with a torque of 30 – 40 Nm (266 – 350 in.lbs.).

SRAM® TORPEDO® SINGLESPEED OPERATION

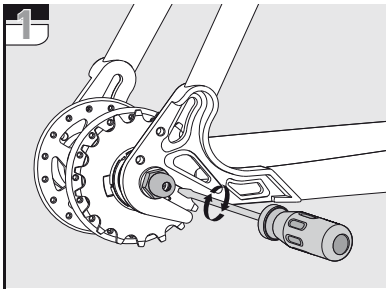

OPERATION

The SRAM Torpedo Singlespeed hub can be used in freewheel mode or alternatively in a fixed gear mode.

The Singlespeed hub comes factory set for freewheel mode.



Caution:

We recommend that you familiarize yourself with the ride characteristics of the Singlespeed hub before using it in traffic. Practice using the hub in a low traffic area, in order to become accustomed to the handling of your bike. Failure to do so may result in a crash which can lead to serious injury.

CHOOSING THE RIDING MODE

The riding mode can be changed with the adjustment screw on the sprocket side.

- » The adjustment screw is located within the axle on the sprocket side (drive side).



Advice:

It is not necessary to remove the axle nut as the adjustment screw is accessible through a hole in the axle nut.

- » **Fixed gear riding mode:**



Using a small screw driver, turn the adjustment screw clockwise until it stops.



Caution:

In fixed gear mode, the pedals are always turning in the same direction as the back wheel. We recommend that you familiarize yourself with the ride characteristics before using this mode in traffic.

- » **Freewheel riding mode:**



Using a small screwdriver, turn the adjustment screw clockwise until it stops, then turn it back 5 full turns counter-clockwise.

SRAM® TORPEDO® SINGLESPEED MAINTENANCE



SERVICE

To maintain optimal performance and durability of your components, periodic maintenance is required. We recommend that you have your components serviced every 2 year or 5000 km by a qualified bicycle mechanic.

CLEANING

Your SRAM Singlespeed components are well protected against adverse environmental effects.

- » The rear wheel hub is not completely waterproof. However, do not use water under pressure (such as pressure washers or water jets) for cleaning to prevent malfunctions due to water penetration.
- » During the winter season, you should clean your bicycle in shorter intervals so that winter road salt cannot cause any damage.
- » Do not use aggressive cleaners.
- » Clean dirty chains before oiling. Let cleaner set for only a few minutes and rinse with water. Do not oil chain until completely dry.

LUBRICATION

- » The rear wheel hub is provided with permanent lubrication and is almost maintenance-free under normal conditions.
- » When dismantling/assembling the gear unit, observe the lubrication guidelines. See „DISMANTLING / ASSEMBLING THE HUB“, from page 54.
- » Regular lubrication will extend the chain's service life.

REPAIR WORK

Caution: Unauthorized work on your components could endanger you and your warranty may become void.

WEAR PARTS

Brake liners or brake sleeve, brake cables, shift cables, handlebar grips, sprockets, and bike chains are wear parts. Please check these parts regularly and replace them well before they are worn out.

Other topics	Page
REMOVING THE REAR WHEEL	53
FITTING THE REAR WHEEL	53
DISMANTLING THE HUB	54
ASSEMBLING THE HUB	55

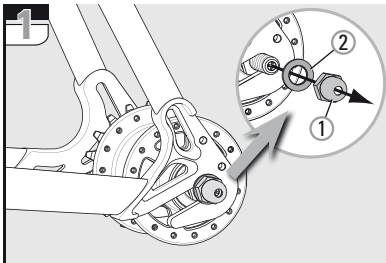

REMOVING THE REAR WHEEL

2 Loosen the axle nuts (1) and remove the nuts and the washers (2) underneath them.

» Remove the rear wheel.

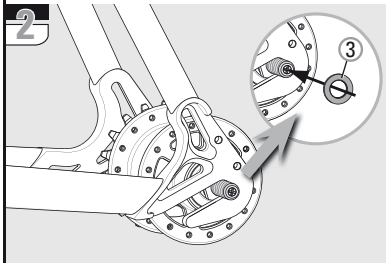

FITTING THE REAR WHEEL

» Place the chain on the sprocket and place the rear wheel into the rear frame. Align the rear wheel.

3 Slide one washer (3) onto each axle end.

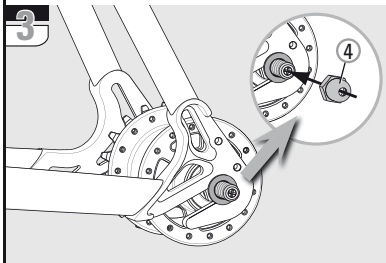

4 Mount the axle nuts (4) and tighten them with a torque of 30 – 40 Nm (266 – 350 in.lbs.).

SRAM® TORPEDO® SINGLESPEED MAINTENANCE

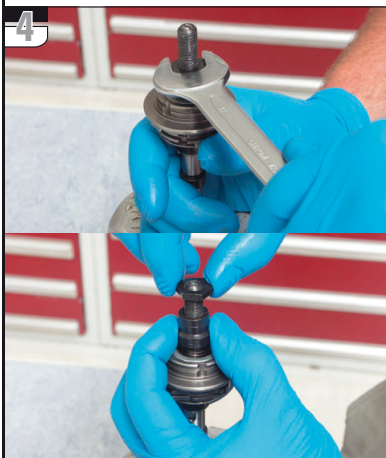

DISMANTLING THE HUB

» If necessary, detach the sprocket retaining ring.

Caution:
The sprocket retaining ring is spring force loaded. Take off the sprocket and the dust cap.

» Clamp the drive side of the axle in a vise.

Advice:
Use a vise with aluminum jaws to prevent damage to the thread of the axle.

1 Unscrew the locknut and the underlying adjusting cone from the axle. Wrench size 17 and 13.

2 Take the hub shell off in an upwards direction.

3 Take off the ball retainer in an upwards direction.

» Clamp the hub with the other axle side in the vise.

4 Unscrew, while holding the fixed cone in position, the locknut from the axle. The fixed cone is spring force loaded.

5 Take off the fixed cone and the and spring from the axle.

6 Take off the driver.

7 Take off the coupling piece.

Advice:
There is a washer inside the coupling piece. This can be lost.

8 Take off the washer from the thrust block. Potentially the washer sticks to the coupling piece.

» Lubrication and assembly details can be found in the following column.

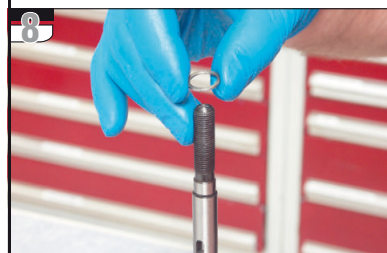

SRAM® TORPEDO® SINGLESPEED MAINTENANCE

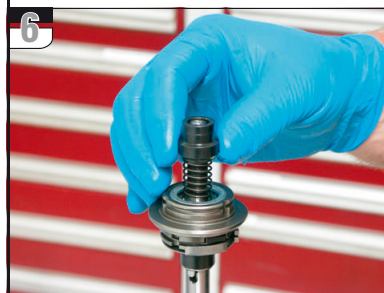
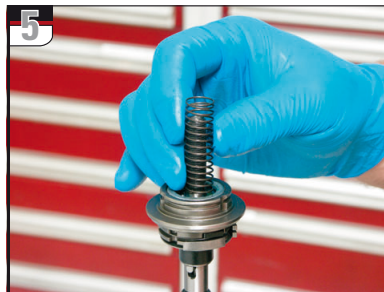
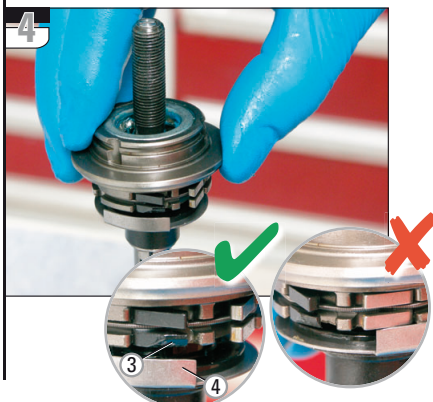
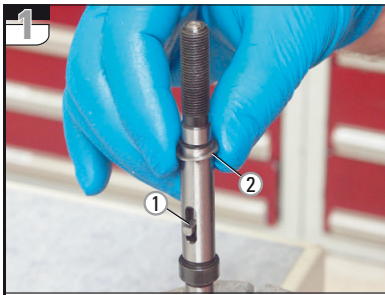

ASSEMBLING THE HUB

Clean the parts after dismantling:

The parts can be degreased in a cleaning bath.

Schmierung der Teile:

Caution: Use only SRAM Ball Bearing Grease, part no. 0369.001.015 and commercially available cycle oil.

Assembling the hub:

Lubrication: Lightly grease the axle. Use only Ball Bearing Grease, part no. 0369.001.015.

1 Place a drop of oil on the thrust block (1).

1 Place the first washer onto the axle.

2 Place the coupling piece onto the axle.

Advice: Normally the second washer is situated inside the coupling piece. If not, place the second washer onto the axle.

Lubrication: Oil the 4 pockets for the pawls and the driver pawl spring. Grease the ball retainer using SRAM Ball Bearing Grease, part no. 0369.001.015.

4 Seat the driver on the coupling piece.

Advice: The chamfered pawls (3) of the driver must be seated in the bent up ends (4) of the coupling piece.

5 Place the spring onto the axle.

6 Place the fixed cone onto the axle.

7 Screw the nut onto the axle and tighten with 15 – 20 Nm. Wrench size 17.

» Clamp the hub with the other axle side in the vise.

SRAM® TORPEDO® SINGLESPEED MAINTENANCE

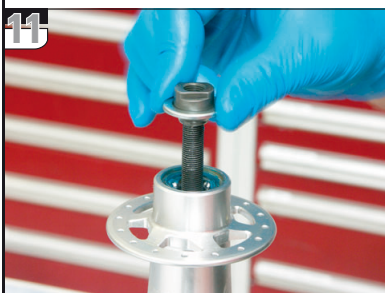
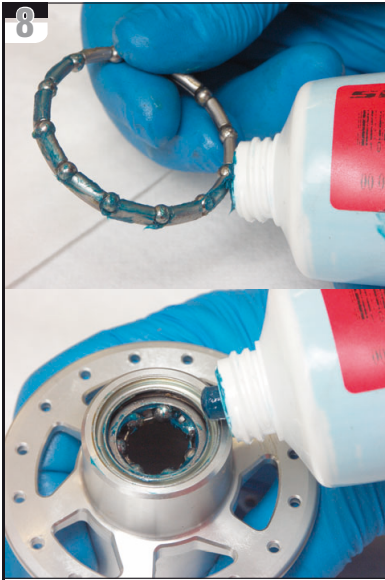

Lubrication:

Grease the large ball retainer and the ball retainer of the hub shell with SRAM Ball Bearing Grease (part no. 0369.001.015). Lightly grease the inside of the hubshell.



Insert the ball retainer with the balls pointing upwards towards the driver.



Position the hub shell. Turning slightly to the left/right eases positioning. Ensure that the hub shell is correctly seated on the ball retainer.



Screw the adjusting cone onto the axle. Tighten to hand-tight.



Screw the locknut onto the axle and tighten hand-tight.



Position the bearing in a play-free manner and tighten using the locknut. Wrench size 13 and 17. Tightening torque 15 – 20 Nm (133 – 177 in. lbs.). Test the play of the bearing and correct if required.

» Clamp the hub with the other axle side in the vise.



» In case you have dismantled the sprocket, set the dust cover onto the driver.

» Place the sprocket onto the driver.



Advice:

When fitting a straight sprocket (not an offset version), the beadings (3) of the sprocket must lie against the dust cover.

» Mount the sprocket retaining ring onto the driver. Check proper seat of the retaining ring.

» Nehmen Sie die Nabe aus dem Schraubstock.

» Fit the rear wheel into the rear frame as described on page 53.



Caution:

Before setting out on any ride, always check the correct and trouble-free operation of the hub and brakes.

SRAM® TORPEDO® SINGLESPEED MAINTENANCE



DUALDRIVE™

TECHNICAL DATA / ASSEMBLY REQUIREMENTS

GEAR HUBS

Caution:
Not suitable for tandems, transport bicycles and similar.

Cycle frame:

- Slot width at rear dropout 10^{+0.5} mm.
- The strength must be such that with a maximum braking torque of 250 Nm (2200 in.lbs.) on the rear wheel no residual deformation can occur on the rear structure.

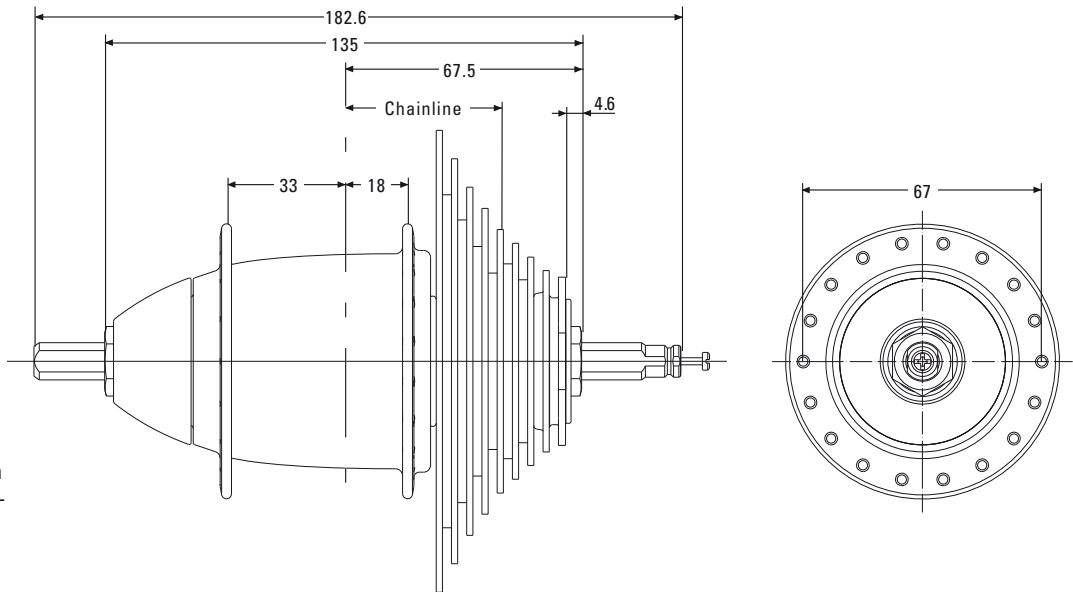

GEAR HUBS

		DualDrive II - Without brake		DualDrive II - Disc brake compatible	
	Version (Speeds)	DualDrive II 27	DualDrive II 24	DualDrive II 27	DualDrive II 24
	Brake	Without brake		Adaptor for Disc brake	
	Over Locknut Dim.	135 mm		135 mm	
	Length	182.6 mm		182.6 mm	
Axle	Ends Diameter	FG 10,5		FG 10,5	
	Holes	36 or 28		36 or 32	
Spoke	Hole Diameter	2.6 mm (28 holes also available in 2,8 mm)		2.6 mm	
	Hole Ref. ø	67 mm		67 mm	
	Flange Dist. to 1/2 OLD	33 mm / 18 mm		33 mm / 18 mm	
Ratio	Totally	573 % (27spd)	539 % (24spd)	573 % (27spd)	539 % (24spd)
	Totally hub	186 %	Gear steps	←	
	Speed 1	0,734	↓	←	
	Speed 2	1,000	36 %	←	
	Speed 3	1,362	36 %	←	
Chain	Chainline	45 mm		42 mm	
	Usable Dimensions	1/2" x 11/128"	1/2" x 3/32"	1/2" x 11/128"	1/2" x 3/32"
Compatibility	Crankset	33 / 38 Teeth		←	
	Cogset	11-34 Teeth	11-32 Teeth	11-34 Teeth	12-32 Teeth
	Cogset	DualDrive 27	DualDrive 24	DualDrive 27	DualDrive 24
	Shifter	DualDrive 27	DualDrive 24	DualDrive 27	DualDrive 24
	Disc brake	—		6 holes	
	Hand Brake Lever	—		Disc brake compatible	
	Tandem	Not suitable for tandems, transport bicycles or similar			
Finish	Sealing	Extra sealed		←	
	Weight	970 g		985 g	
	Hub Shell	Aluminum, silver anodized		Aluminum, silver anodized	
	Shifting device	Composite		Composite	

DUALDRIVE™ TECHNICAL DATA / ASSEMBLY REQUIREMENTS



SHIFTERS

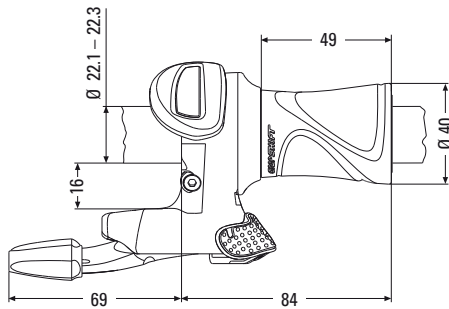

Shifter DualDrive 27

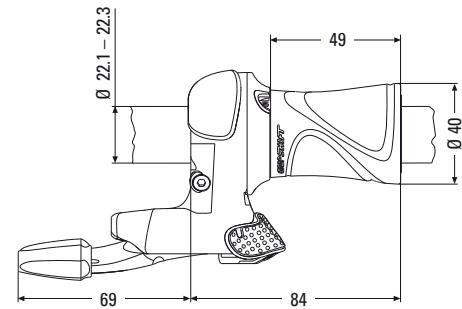
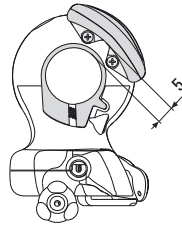

Shifter DualDrive 24

SHIFTERS

		DualDrive single sided shifter	
		DualDrive 27	DualDrive 24
	Version	DualDrive 27	DualDrive 24
	Clickbox Cable	1400 mm / 1500 mm / 1600 mm / 1700 mm / 2100 mm	
	Shifter Type	SRS Twisting-Thumbshifter-Combo (2in1)	
	Arrangement	Right side of handlebar	←
Comp- pat.	Gear Hub	DualDrive 27	DualDrive 24
	Derailleur	DualDrive 27	DualDrive 24
	Gear Indication Der.	Window	Printed
	Riding Mode Indic.	Printed	Printed
	Barrel Adj. Gear Hub	None	←
	Barrel Adj. Derailleur	Indexing	←
	Clamping Diameter	22.1 – 22.3 mm	←
	Straight handlebar ends	Minimum necessary length for shifter and handlebar grip = 150 mm	
	Cable Routing, Gear Hub	Continuous housing (preassembled)	←
	Cable Routing, Der.	Open or continuous	←
	Weight	N/A	←
Design	Cables	Stainless steel	←
	Housing	Glass filled PA – Silver painted	←
	Grip Cover	Thermoplastic elastomer	←
	Clamping Collar	Aluminum	←
	Clickbox	Composite	←

DUALDRIVE™

TECHNICAL DATA / ASSEMBLY REQUIREMENTS

DERAILLEURS

	DualDrive 27	DualDrive 24
Speeds	9 / 8	9 / 8
Shifter Compatibility	DualDrive 27	DualDrive 24
Cage Length	Short, 75 mm	Short, 75 mm
Sprocket, max.	34 Teeth	32 Teeth
Sprocket, min.	11 Teeth	11 Teeth
Pulleys	Exchangeable / Bushing	Exchangeable / Bushing
Direct Mount	Yes	Yes
Weight	258 g	265 g
Upper Knuckle	Aluminum, forged	Aluminum, forged
Lower Knuckle	Grilon® Composite silver	Grilon® Composite silver
Outer Link	Aluminum	Grilon® Composite silver
Inner Link	Steel / Zinc coat	Steel / Zinc coat
Outer Cage	Aluminum, forged	Grilon® Composite black
Inner Cage	Grilon® Composite black	Grilon® Composite black
Hanger Bolt	Aluminum	Steel

Design

CASSETTES

	DualDrive 27	DualDrive 24
Largest Cog	34 Teeth	32 Teeth
Speeds	9	8
Cogs	11/13/15/17/20/23/26/30/34	11/12/14/16/18/21/26/32
Spacers	Dark Gray	Black
Chain compatib.	9spd, HG® / IG® / PC comp.	8spd, HG® / IG® / PC comp.
Weight	410 g	280 g
Cogs	SAPH 440 Stahl	←
Screws	Steel / Zinc Coat	←
Finish	Chrome, matt	Chrome

Design

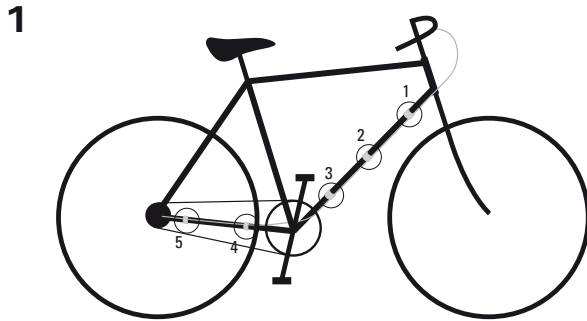

Cable routing	DualDrive 27 / DualDrive 24
Hub cable	Along chainstay only
Derailleur cable	Along chainstay only

Cable attachment siehe Bild 1	Cable housing	Attachment points	Cable stops
Hub	Continuous	1/2/3/4 (see Fig. 1)	—
Derailleur	Continuous	1/2/3/4/5 (see Fig. 1)	—
	Open	—	1/5 (Fig. 1)

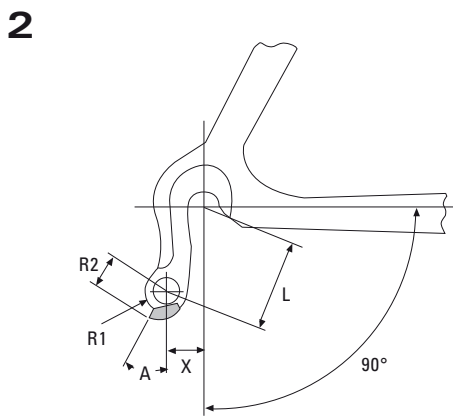

CABLE HOUSING FOR DERAILLEUR

Rear cable stop position

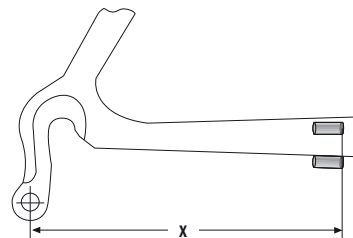

Length X min. 90 mm.
Cable stop below or beside chainstay.

Rear housing length

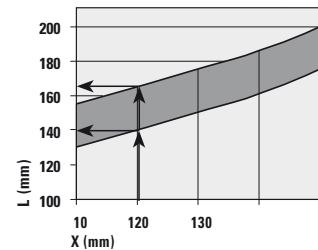

Example: Distance X = 100 mm → cable housing length L = 140 – 165 mm.

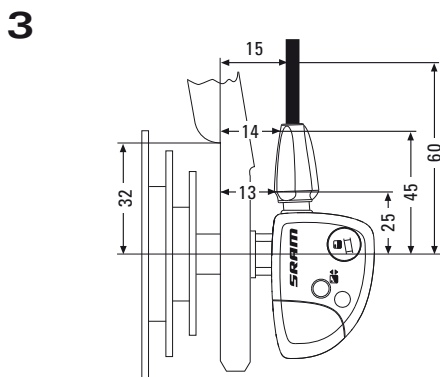

CABLE HOUSING

- Use only new high quality cable and compressionless cable housing with end caps.
- When choosing cable housing lengths, be sure to allow enough housing for an extreme turn of the handlebars in both directions.
- Note also, that different stem lengths and cable stop positions effect cable housing length.

CRANKSET

Bicycle without chain case:
Use a chain guard disc (at the outer surface of chainring, material no resin)
Use only standard chainring version (non-shifting teeth).
Number of teeth: 33 / 38
Chainline: 45 mm

DROPOUT

Only flat and no off-set versions.
Dropout thickness: 7 – 8 mm.
Vertical or horizontal dropout slot.
Dropouts must be parallel.

Dropout dimensions: *see Fig. 2 and 3.*

L	X	A	R1	R2
28	6–10	25°–30°	8.5 max	11.5–13.5
30	7.5–10	25°–30°	8.5 max	11.5–13.5

CHAIN GUIDE FORK

It prevents chain from jumping off front chainring, is bolted inside the chain case (1, Fig. 4).

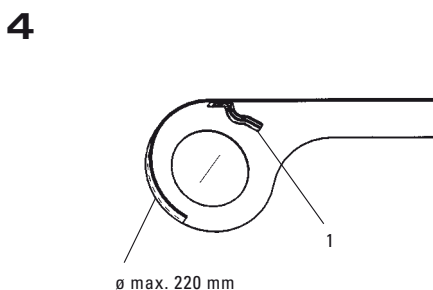

HANDLEBAR

Diameter: 22.3 mm.
Minimum length of straight area for shifter: 150 mm.
Check the compatibility of intended handlebars and brake levers.

DUALDRIVE™ ASSEMBLY

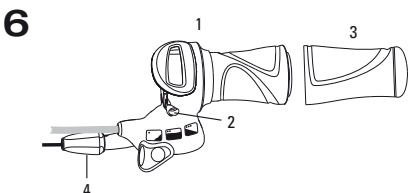
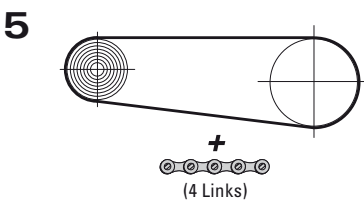
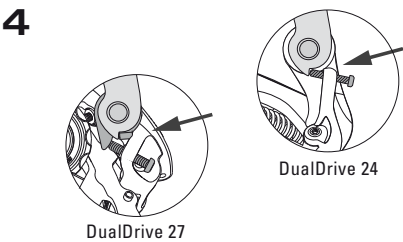
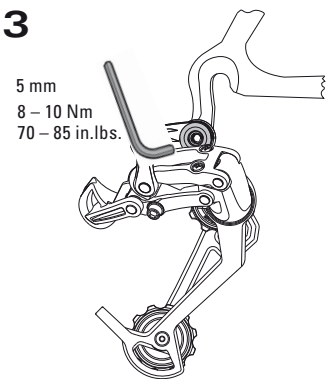
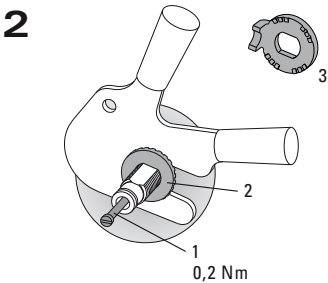
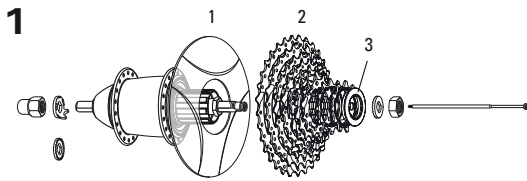

ASSEMBLY HUB

- Lace the wheel as normal.
- Place spoke protector disc (1, Fig. 1) on shoulder of hub, fit cassette (2) onto driver profile. Screw lock nut (3) with cassette tool (Park Tool FR-5 or SRAM Part No. 4624 411 010), tightening torque: 40 Nm (350 in.lbs.).
- Screw shifting rod (1, Fig. 2) into the hub axle and tighten it with 0.2 Nm (1.8 in.lbs.).
- Fit wheel in dropouts.
- Hub versions for i-BRAKE and Disc Brake:

Advice:

Read and observe the corresponding technical documentation for assembling the disc of the disc brake.

Caution:

Plane faces of the hub and the disc and the threaded holes of the hub must be clean and free from oily and greasy substances.

- Place one retaining washer without lug (2, Fig. 2) on right axle end (drive side). The serrations must bear against the dropout.
- Place one retaining washer with lug (3, Fig. 2) (new version, 3,5 mm thick) on left axle end (non-drive side). The lug must engage in the dropout slot. On vertical dropouts, fit one retaining washer without lug on each axle end. The serrations must bear against the dropout.
- Tighten up axle nuts. Tightening torque 30 – 40 Nm (266 – 350 in.lbs.).

ASSEMBLY DERAILLEUR

Advice:

Check the rear derailleur hanger alignment. A bent rear derailleur hanger will result in inaccurate index shifting.

- Attach the rear derailleur to the frame's rear derailleur hanger using a 5 mm hex head wrench (Fig. 3).
- Check that the b-adjust washer tab (b-adjust screw at DualDrive 24) is clear of the rear derailleur dropout tab (Fig. 4).
- Tighten the 5 mm hex hanger bolt to 8 – 10 Nm (70–85 in.lbs.).

CHAIN LENGTH

- Bypassing the rear derailleur, run the chain around the largest cog/large chainring combination (Fig. 5).
– For rear suspension frames, position the rear suspension for the greatest chain length required.
- Add 4 LINKS or 3 link + Connecting Link to this length for proper chain length.

ASSEMBLY SHIFTER

Caution:

- **Never use lubricants or solvents to install handlebar grips. Handlebar grips provide safety function.**
For this reason, they should be mounted in such a way as to make sure they do not slip off handlebar!
- **Always check the front and rear brake levers for proper operation.**
If there is interference between shifters and brake levers, re-adjust lever and shifter placement.

- Slide the shifter (1, Fig. 6) onto the handlebar.
- Rotate the shifter until the barrel adjuster (4) is beneath (but out of the way of) the brake lever.
- Tighten the 3 mm hex clamp bolt (2) to 1.9 – 2.5 Nm (17 – 22 in.lbs.).
- Slide the handlebar grip (3) onto the handlebar.

INSTALLING CLICKBOX

- Fit the cable and avoid small radius.
- Cable attachment points *see Page 49 / Fig. 1.*
Cable housing must be movable inside attachment.
- Place shift lever in uphill riding mode / gear position „1“ (Fig. 7).
- Push Clickbox button down (Fig. 7).
- Push on Clickbox to the stop on the hub axle.
- Press button up.
- Place thumb shift lever in standard riding mode / gear position „2“ (Fig. 8).
- Match up the marks in the Clickbox viewing window by twisting the barrel adjuster (Fig. 8).



7

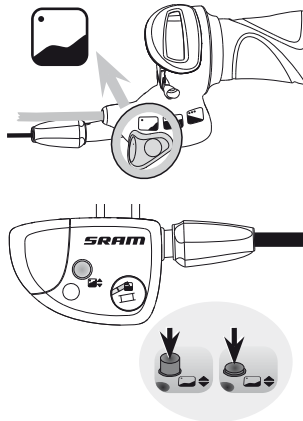

8

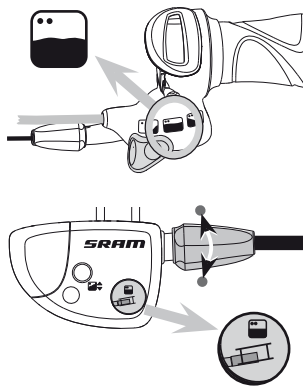

9

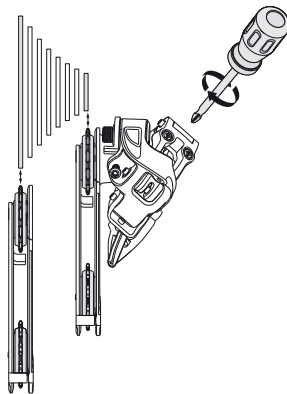

10

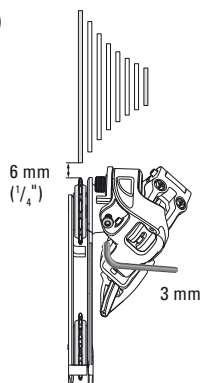

DERAILLEUR ADJUSTMENT

Limit screw adjustment:

- View the rear derailleur and pulleys from behind the rear of the bicycle (**Fig. 9**).
- Using a small screwdriver, turn the limit screw marked 'H' on the outer link of the derailleur to align the upper guide pulley center with the outboard edge of the smallest cog – clockwise moves the guide pulley inboard towards the wheel.
- While turning the crank, push the rear derailleur towards the larger cogs by hand.
- Align the upper guide pulley under the largest cog, center to center, by turning the limit screw marked 'L' on the outer link – clockwise moves the guide pulley outboard away from the spokes.

Chain gap adjustment:

Chain gap is the distance between the upper guide pulley and the cog the chain is riding on. Optimal chain gap is small enough to allow quick, efficient shifts to and from any cog, but large enough to allow smooth shifts to and from the largest cog.

- Shift chain to the small chain ring.
- While turning the crank, push the rear derailleur inboard by hand to the largest cog.
- Hold the derailleur in this position while making the following adjustment.
- Use a 3 mm hex wrench, turn the b-adjust screw until the chain gap equals approximately 6 mm ($\frac{1}{4}$ ") from tip of the cog to tip of upper guide pulley (**Fig. 10**).
- Turn the b-adjust screw clockwise to increase the chain gap.
- Turn the b-adjust screw counterclockwise to decrease the chain gap.

Advice:

Do not use the b-adjust screw to adjust the rear derailleur to act as a chain-tensioning device or to prevent chain suck. This increases the chain gap causing poor shifting performance.

Index shifting adjustment:

- Check that the chain and the rear derailleur are in the smallest cog position.
- Measure and cut the rear piece of cable housing. Make sure that it is not too short or long (*see page 61 for figure and chart*).
- Rotate the twist shifter until the largest number and gear indication tab/dash line up.
- Turn the twist shifter barrel adjuster (4, **Fig. 6**) clockwise fully into the shifter, then turn counterclockwise 1 full turn.
- Feed the shifter cable through the rear derailleur cable housing, stops and cable guides.
- Feed the rear derailleur cable through the rear derailleur-housing stop and through the cable guide on the fin.
- Pull the cable tight and position it under the cable anchor washer (**Fig. 11**).
- Tighten the 5 mm hex cable anchor bolt to 4 – 5 Nm (35 – 45 in.lbs.).
- Rapidly shift the chain and derailleur up and down the cassette several times. If the cable slips repeat the two former steps.
- Shift the chain to the smallest cog.
- While pedaling, move the shifter up one detent.
 - If the chain hesitates or does not shift to the second cog, increase the cable tension by turning the shifter barrel adjuster counterclockwise.
 - If the chain shifts beyond the second cog, decrease the cable tension by turning the shifter barrel adjuster clockwise.
- Repeat the two former steps until shifting and cable tension is accurate.
- While turning the crank, shift the chain up and down the cassette and chain rings several times to ensure that your derailleur is indexing smoothly.

11

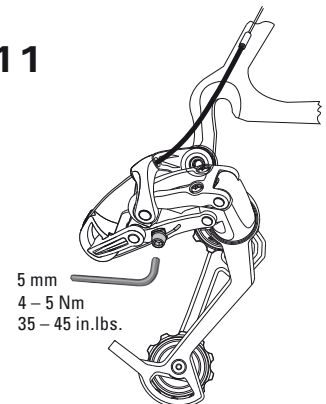

DUALDRIVE™ MAINTENANCE

1

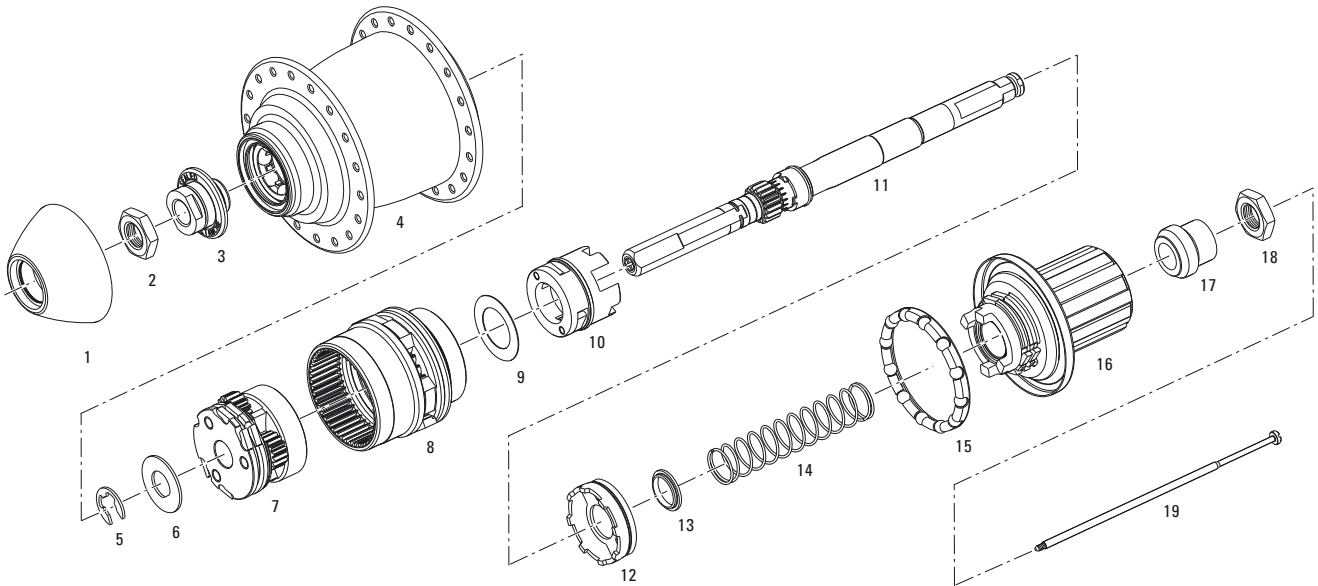

2

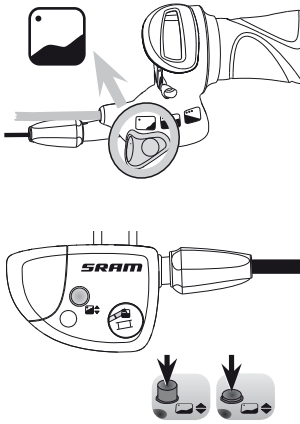

3

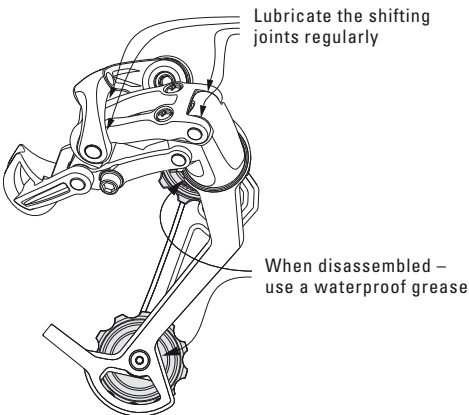

SERVICE

To maintain optimal performance and durability of your components, periodic maintenance is required. We recommend that you have your components serviced every 2 year or 5000 km by a qualified bicycle mechanic.

REMOVE WHEEL

- Rotate the twist shifter to the highest gear position (speed “8/9”).
- Place shift lever in uphill riding mode / gear position “1” (Fig. 2).
- Push Clickbox button down (Fig. 2).
- Pull Clickbox off the axle.
- Screw out shifting rod (19, Fig. 1).
- Dismantle wheel.

DISMANTLING HUB

see Figure 1

- Dismantle cassette lock nut with cassette tool (Park Tool FR-5 or SRAM Part No. 4624 411 010).
- Remove cassette and spoke protector disc.
- Clamp hub with the two axle flats (driverside facing downwards).
- Remove cap (1), unscrew lock nut (2), screwed adjusting cone (3) and hub shell (4).
- Dismantle retaining washer (5), remove washer (6), planetary gear carrier (7) and gear ring (8).
- Squeeze down pawls and remove pawl carrier (10) with washer (9) and ball retainer (15).
- Clamp other axle end (longer axle thread).
- Dismantle lock nut (18) and cone (17).
- Remove driver (16), compression spring (14) and shift sleeve (12) with bushing (13).

REASSEMBLY HUB

see Fig. 1

Lubrication see “LUBRICATION GEAR HUB”.

- Clamp axle with the two axle flats (longer axle thread).
- Fit shift sleeve (12), bushing (13) with small diameter first, compression spring (14), and driver (16).
- Mount cone (17) and lock nut (18). Tightening torque 15 – 20 Nm (133 – 177 in.lbs.).
- Clamp other axle end (driver side facing downwards).
- Mount ball retainer (15), pawl carrier (10) and washer (9).
- Press pawls against spring force and mount gear ring (8) with smaller diameter first.
Rotate gear ring counterclockwise until pawls engage inside the gear ring.
- Fit planetary gear carrier (7) and washer (6).
- Press and rotate planetary gear carrier until axle groove is visible.
- Mount retaining washer (5).
- Mount hub shell (4), obligatory with a slight counterclockwise turn.
- Mount adjusting cone (3).
- Screw on conternut (2), adjust bearings to be nearly free of play and tighten with a torque of 15 – 20 Nm (133 – 177 in.lbs.).
- Mount cap (1).
- Unclamp hub and mount shifting rod (19) with a torque of 0,2 Nm (1.8 in.lbs.). Mount spoke protector disc and cassette.



4

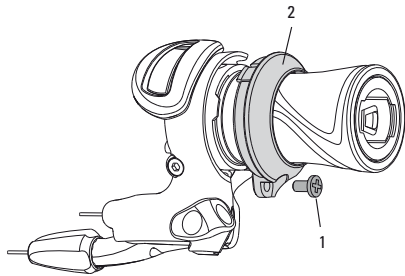

5

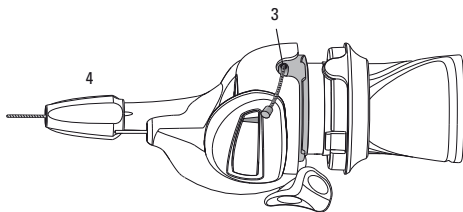

6

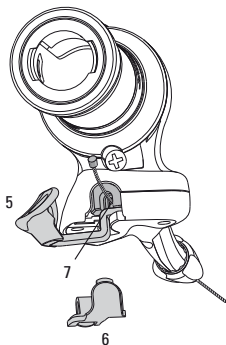

7

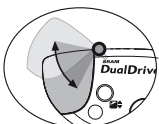
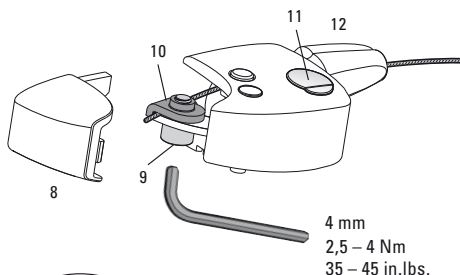

LUBRICATION GEAR HUB

Hubs are provided with permanent lubrication and maintenance-free under normal conditions.

Cleaning of parts:

- All parts – except the planetary gear carrier and the driver – can be degreased in a cleaning bath.
- Planetary gear carrier and driver only need to be cleaned on the outside with a brush so as not to degrease the bearings.

Lubrication of parts:

- Use only SRAM special grease, part no. 0369 135 200 / ... 201.
- Lubricate ball retainers and ball tracks only with SRAM Ball Bearing Grease. Part no. 0369.001.015.
- To lubricate the bearing points on the planetary gear sets, position the planetary gear carrier pawls upside and apply 2 – 3 drops of oil to the bearing bolts – at the same time turning the planetary gears so that the bearing points are completely wet. Oil axle slot, apply a thin coating of grease to the outside.
- Grease the teeth of the axle (fill the gaps).
- Apply grease to gear ring teeth but just oil the pawls and pawl teeth.
- Oil pawl carrier pawls and pawl bearings.
- Oil cartridge bearing.
- Regrease ball retainers, line ball bearing running tracks with grease.

Caution:

The rear wheel hub is not completely waterproof. To prevent water ingress and any resultant malfunctioning, do not use pressurized water (e.g. pressure washers) for cleaning.

LUBRICATION REAR DERAILLEUR

- Do not use solvents or corrosive materials to clean the components.
- Lubricate the shifting joints regularly (Fig. 3).
- Grease any cable guides (e.g. beneath the bottom bracket).

CABLE CHANGE

Advice:

Use only new high quality cable and compressionless cable housing with end caps.

Twist shifter (rear derailleur):

- Detach the cable from the derailleur.
- Cut cable off 15 cm (6") from shifter barrel adjuster. Discard old cable and cable housing.
- Remove screw (1, Fig. 4) and pull open the cable change sleeve (2).
- Rotate the shifter fully in the cable release direction (gear position "8/9").
- Look for cable head entry (3, Fig. 5).
- Push cable up/out of the shifter and discard.
- Feed the new cable through the cable entry and out the barrel adjuster (4).
- Pull cable snug.
- Install cable change sleeve (2, Fig. 4).
- Feed the cable through the new cable housing and frame stops.
- Attach cable to the derailleur.
- Adjust indexing per derailleur instruction.

Thumb shift lever (gear hub):

- Place thumb shift lever (5, Fig. 6) in uphill riding mode / gear position "1".
- Remove Clickbox from the axle (see page 64).
- Snap open Clickbox-cover (8, Fig. 7) as shown.
- Unscrew clamping bolt (9).
- Remove the shifter escape hatch (6, Fig. 6).
- Remove and discard the old cable.
- Feed the new cable through the cable entry (7, Fig. 6), the new cable housing and pull the cable snug.
- Attach the escape hatch.
- Pull the cable tight and position it under the cable anchor washer (10, Fig. 7).
- Tighten the 4 mm hex cable anchor bolt to 2.5 – 4 Nm (22 – 35 in.lbs.).
- Cut off cable end to 1 – 2 mm.
- Snap in Clickbox-cover (8).
- Install Clickbox (see page 62).
- Place thumb shift lever in standard riding mode / gear position "2".
- Match up the marks in the Clickbox viewing window (11, Fig. 7) by turning the barrel adjuster (12).

DUALDRIVE™ MAINTENANCE

TROUBLESHOOTING

Problem	Cause	Remedy
Hub: Shifting difficulties	Incorrect gear setting	Adjust shifting system, oil control cable, check that cable stop is fastened correctly.
	To much additional axle attachments between hub and axle nut on clickbox side.	Reduce dimension of axle attachments.
	Shifting rod is not screwed completely into the axle.	Screw in shifting rod completely and tighten it with a torque of 0,2 Nm (1.8 in.lbs.).
Pedals are carried forward when freewheeling	Bearings set too tight	Re-adjust bearing
	Loose lock nuts	Tighten lock nuts (15 – 20 Nm, 133 – 177 in.lbs.)
	Rear frame dropouts non parallel	Bend / reorient dropouts
Derailleur: Chain jumps from smallest sprocket to frame dropout.	High gear limit screw is not adjusted properly.	Turn in screw H until the guide pulley is aligned with the smallest sprocket.
Difficult or impossible to shift chain onto smallest sprocket.	High gear limit screw is not adjusted properly.	Unscrew screw H until the guide pulley is aligned with the smallest sprocket.
Chain jumps over largest sprocket and falls between the spokes and largest sprocket or inner cage plate scrapes on spokes.	Low gear limit screw is not adjusted properly.	Turn in screw L until the guide pulley is aligned with the largest sprocket.
	Rear derailleur or derailleur hanger is bent.	Straighten or replace.
Delayed shifting.	Clearance between guide pulley / sprocket is too large.	Adjust b-adjust screw by rotating counterclockwise.
Rough shifting behavior.	Clearance between guide pulley / sprocket is too small.	Adjust b-adjust screw by rotating clockwise.
Shifts more gears onto smaller sprockets as intended	Shift cable insufficiently tensioned.	Turn barrel adjuster on the shifter counterclockwise.
Delayed shifting onto larger sprocket	Shift cable insufficiently tensioned.	Turn barrel adjuster on the shifter counterclockwise.
Delayed shifting onto smaller sprocket	Shift cable is too tight.	Turn barrel adjuster on the shifter clockwise.
	Excessive cable friction, pinched or poorly routed cable.	Lubricate or replace cable and housing. Check for excessive bending of cable housing.



SRAM® S7 TECHNICAL DATA / ASSEMBLY REQUIREMENTS

S7

Caution:
Not suitable for tandems, transport bicycles and similar.

Cycle frame:

- Dropouts must be parallel.
- Slot width at rear dropout 10^{-0.5} mm.
- The strength must be such that with a maximum braking torque of 250 Nm (2200 in.lbs.) on the rear wheel no residual deformation can occur on the rear structure.

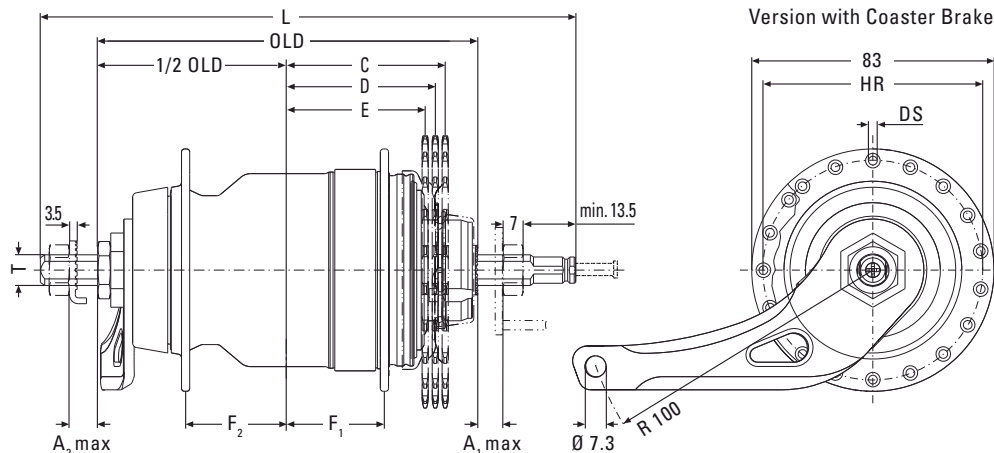

GEAR HUBS

		SRAM S7 with coaster brake	SRAM S7 without brake
	Type	MH 7215	MH 7205
	Brake	With coaster brake	Without brake
Over Locknut Dim., OLD		130 mm	130 mm
Axle	Length, L	183.4 mm	183.4 mm
	Ends Diameter, T	FG 10.5	FG 10.5
	Dropout Width Dim.	A ₁ max. = 12.5 mm / A ₂ max. = 12 mm	A ₁ max. = 12.5 mm / A ₂ max. = 10 mm
Spoke	Holes	36	36
	Hole Diameter, DS	3.0 mm	3.0 mm
	Hole Ref. ø, HR	75 mm	75 mm
	Flange Dist. to 1/2 OLD	F ₁ = 33 mm / F ₂ = 34 mm	F ₁ = 33 mm / F ₂ = 34 mm
Gear Hub Ratio	Totally	303 %	←
	Speed 1	0,574	←
	Speed 2	0,677	←
	Speed 3	0,809	←
	Speed 4	1,000	←
	Speed 5	1,236	←
	Speed 6	1,476	←
	Speed 7	1,742	←
Chain	Usable Dimensions	1/2" x 1/8" or 1/2" x 3/32"	1/2" x 1/8" or 1/2" x 3/32"
	Line, C/D/E	C = 54 mm / D = 51 mm / E = 48 mm	C = 54 mm / D = 51 mm / E = 48 mm
	Ratio	24", 26", 28" = 1.83 - 1.90 / 20" = 1.83 - 2.00	min. 1.83
Compatibility	Sprocket	16 - 24 Teeth (outward offset - Chain Line C) / 18 Teeth (straight - CL D) / 19 - 24 Teeth (inward offset - CL E)	
	Shifter	SRAM Grip 7	←
	Clickbox	Clickbox S7	←
	Tandem	Not suitable for tandems, transport bicycles or similar	
Finish	Weight	1714 g	1556 g
	Hub Shell Material	Steel	Steel
	Finish	Matt Chrome Plated or Black	Matt Chrome Plated or Black

SRAM® S7

TECHNICAL DATA / ASSEMBLY REQUIREMENTS

SHIFTER

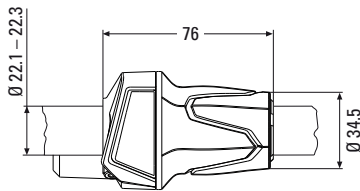

SHIFTER

SRAM Grip 7

Design	Shifter Type	Twist Shifter mit Clickbox							
	Cable Length	Black housing: 1400 mm	1500 mm	1600 mm	1700 mm	1800 mm	1900 mm	Grey housing: 1650 mm	1750 mm
	Gear Indication	Window							
	Clamping Diameter	22.1 – 22.3 mm							
	Straight handlebar ends	Minimum necessary length for shifter and handlebar grip = 150 mm							
	Length of shifter	76 mm							
	Weight	N/A							
	Housing	Glass filled PA, black or grey							
	Grip	PP							
	Grip Cover	Thermoplastic elastomer, Overmolded							
	Clamping Collar	Aluminum							

SRAM S7 ASSEMBLY

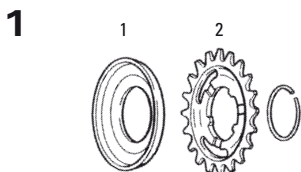

ASSEMBLY HUB

- Lace the wheel as normal. See spoke length table.
 - Place the dust cap (1, Fig. 1) and sprocket (2) on the driver.
- Advice:**
When fitting a straight sprocket (not an offset version), the beadings of the sprocket must lie against the dust cap.

- Push sprocket circlip (3, Fig. 2) onto the cone of tool sleeve (4). Place tool sleeve with large diameter on the driver.
- Push the spring end of sliding sleeve (5) of the tool over the tool sleeve. Thrust sliding sleeve in direction (6), this forces circlip into the recess of the driver.
- Remove tool and check that the circlip is seated correctly.

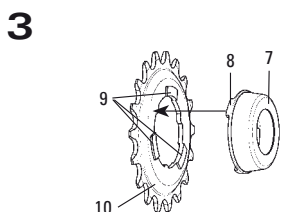
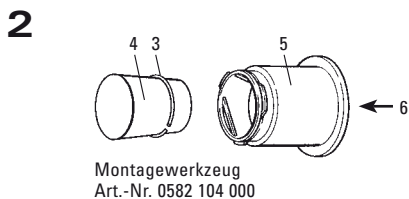

Spoke length table

Tire Size		Cross	Length
47-406	20" x 1.75 x 2	3 x	181 mm
37-490	22" x 1 3/8	3 x	225 mm
47-507	24" x 1.75 x 2	3 x	232 mm
37-540	24" x 1 3/8	3 x	251 mm
47-559	26" x 1.75 x 2	3 x	259 mm
37-590	26" x 1 3/8	3 x	275 mm
47-622	28" x 1.75	3 x	289 mm
37-622	28" x 1 3/8 x 1 5/8	3 x	289 mm
28-622	28" x 1 1/8	3 x	289 mm
32-622	28" x 1 5/8 x 1 1/4	3 x	289 mm
28-630	27" x 1 1/4 fifty	3 x	294 mm
32-630	27" x 1 1/4	3 x	294 mm

Spoke lengths are approximate values. They must be checked through lacing attempts and adjusted accordingly.

4

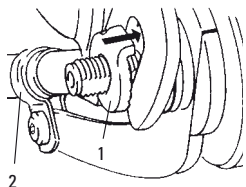

5

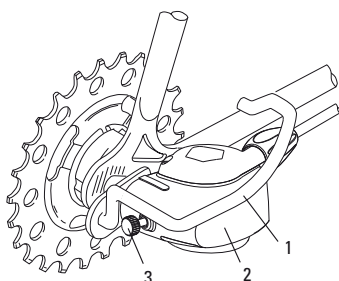

6

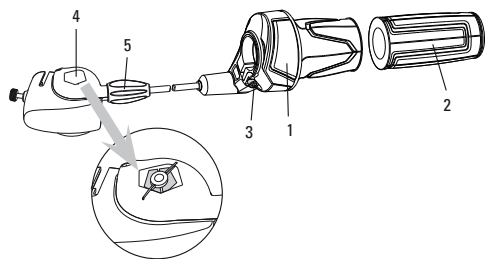

7

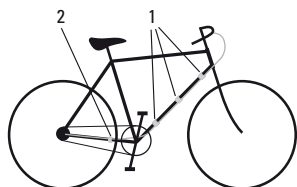

8

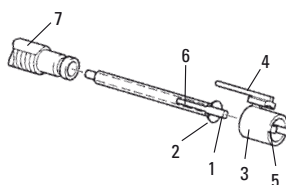

- Turn dust cap (7, Fig. 3) until the three lugs (8) are between the three beads (9) on the sprocket (10).
- Position dust cap and push towards sprocket until it is felt to lock into place.
- Placing the wheel in the rear frame.
- Fit new retaining washer (3,5 mm thick) on left axle end (1, Fig. 4).

The serrations must bear against the dropout and the lug must engage in the dropout slot.

- Fit the hoop guard (1, Fig. 5) on the right axle side (drive side). No additional washers or any accessories are permitted.

Advice:
If a different protective bracket is used the thickness of the attachment plate must be max. 3 mm.

At least the beginning of the axle thread must be visible in front of the axle nut.

- Mount the axle nuts. Tightening torque on axle nuts 30 – 40 Nm (266 – 350 in.lbs.)
- Version with coaster brake: Mount the brake lever using a suitable frame clamp (2, Fig. 4).

Caution:
Mount the brake lever between the two straps of the frame clamp.

The clamp must be seated on the frame without play.

Use a self-locking nut! Tightening torque: 2 – 3 Nm (18 – 27 in.lbs.).

Caution:
Check that all the brake system components are functioning properly!

ASSEMBLY SHIFTER

Advice:

- When choosing cable housing lengths, be sure to allow enough housing for an extreme turn of the handlebars in both directions.
- Note also, that different stem lengths and handlebar positions effects cable housing length.

- Slide the shifter (1, Fig. 6) onto the handlebar.
- Slide the handlebar grip (2) onto the handlebar.

Caution:
Never use lubricants or solvents when fitting handlebar grips. They have a safety function and must not come free from the handlebar.

- Place the shifter on the handlebar grip and position so that you can use it comfortably. Tighten the clamping bolt (3). 3 mm Allen key, torque 3.5 – 4 Nm (31 – 35 in.lbs.).

Caution:

- Check that shifter and brake lever can be easily operated (if necessary, realign).
- Never ride without handlebar grips. The turning grip of the twist shifter could become loose. This can result in severe injuries.

- When fitting the cable avoid small radius. Attach the cable 3 times to the down tube (1, Fig. 7).

- Last attachment point is on the lower rear wheel fork (2, Fig. 7) immediately behind the chain wheel.

Cable housing must be movable inside attachment.

INSTALLING CLICKBOX

- Insert shift rod (1, Fig. 8) in shift tube (2) (oil parts lightly) and then push into axle bore as far as the stop. Turn slot (6) in shift tube to a position where it is easily visible.

- Push locating sleeve (3) with guiding rib (4) to the front onto the hub axle – making sure that the internal lug (5) is guided in the slot (6) of the shift tube until it can be felt – and heard – to engage.

- Turn locating sleeve on the axle until the guiding rib (4) is facing roughly upwards.

- Place shifter in gear position “1”.
- Push on Clickbox (2, Fig. 5) to the stop on the hub axle. The guiding rib (4, Fig. 8) of the locating sleeve thereby engages in the slot on the housing. In the end position tighten up the knurled bolt (3, Fig. 5) by hand (0.3 Nm / 2.7 in.lbs.).

ADJUSTMENT

- Be sure to reset rotational shifter from 5th to 4th gear.
- Match up the marks in the Clickbox viewing window (4, Fig. 6) by turning the barrel adjuster (5).

Caution:
Check that all the brake system components are functioning properly!

SRAM® S7 MAINTENANCE

1

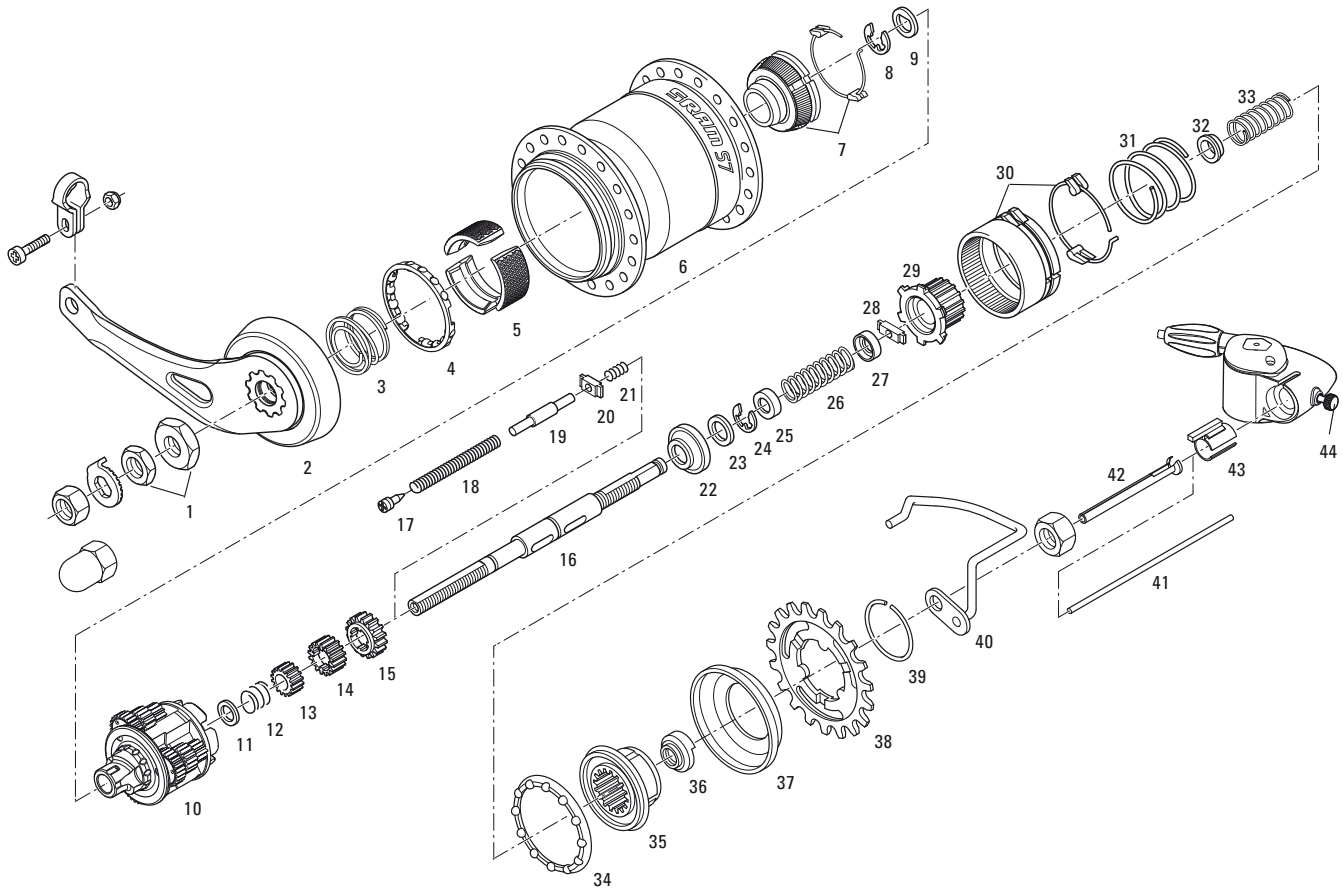

2

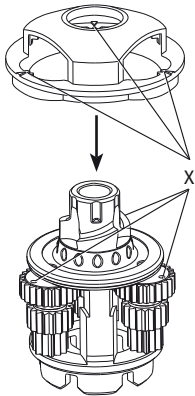

SRAM S7 mounting aid
Part No. 65 0324 103 000

3

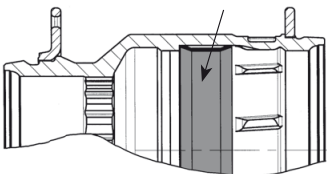

SERVICE

To maintain optimal performance and durability of your components, periodic maintenance is required. We recommend that you have your components serviced every 2 year or 5000 km by a qualified bicycle mechanic.

REMOVE WHEEL

- Place shifter in gear position "1".
- Loosen the knurled screw (44, **Fig. 1**) and pull the Clickbox off the axle.
- Disengage the red location sleeve (43) and pull it off.
- Remove shift rod (42) and shift tube (41) out of the axle bore.
- Remove wheel.

DISMANTLING HUB

see **Fig. 1**

- Remove circlip (39), sprocket (38) and dust cap (37) as normal.
- Clamp hub by the axle between aluminum jaws with sprocket side facing downwards.
- Unscrew both locknuts (1).
- While turning clockwise, remove lever cone (2) with friction spring (3) and ball retainer (4).

- Take out 3 brake segments (5).
- Withdraw hub sleeve (6) upwards.
- Remove brake cone (7).
- Take out retaining washer (8) and thrust washer (9).
- Remove planetary gear carrier (10), washer (11) compression spring (12) and the three sun gears (13, 14, 15).
- Clamp other axle end.
- Clamp fixed cone (36).
- Remove driver (35), compression spring (33) with cover (32), large compression spring (31), ball retainer (34), gear ring (30) and coupling gear (29).
- Compress spring (26) and remove thrust block (28).
- Remove cover (27), spring (26) and cover (25).
- Dismantle retaining washer (24).
- Remove thrust washer (23) and plastic profile washer (22).
- Unscrew grub screw (17) (Caution: It is subject to spring pressure) – and dismantle the long compression spring (18) guide pin (19), thrust block (20) and the short compression spring (21).

4

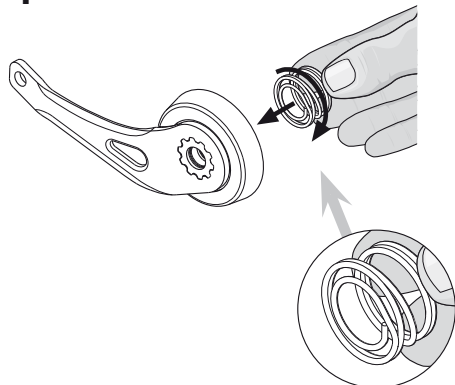

REASSEMBLY HUB

see Fig. 1

Lubrication see "MAINTENANCE / LUBRICATION".

- Insert into the axle (on the side with the internal thread):
Short compression spring (21), thrust block (20) – it is the same both sides, guide rod (19) – it is the same both sides, long compression spring (18).
- Compress spring and fit grub screw (17).
- Clamp axle, end with groove for Clickbox facing upwards.
- Fit plastic profile washer (22) with its large diameter upwards.
- Fit thrust washer (23) and retaining washer (24).
- Locate cover (25), compression spring (26) with 7 turns and cover (27, insides to the spring).
- Compress spring and position thrust block (28) – it is the same both sides – centrally in the axle.
- Clamp other axle end (groove is facing downwards).
- Fit large sun gear (15), with deflector bevels upwards.
- Position medium sun gear (14), with deflector bevels upwards.
- Fit small sun gear (13) – with recesses in front, thrust block engages in the slots.
- Position smallest compression spring (12).
- Fit 1 mm thick washer (11).
- Fit planetary gear carrier (10):
Place the mounting aid (Fig. 2) on the planetary gear carrier such that the markings (X) on the 3 small planet gears and the mounting aid match up.
- Turn planetary gear carrier and at the same time push it downwards over the sun gears.
- Fit thrust washer (9) and retaining washer (8) in the undercut.

Now remove the mounting aid.

Advice:

If the gears are not accurately assembled the hub may feel tight in use. This may lead to gear wheel damage during travel.

- Clamp other axle end (groove for Clickbox facing upwards).
- Fit coupling gear (29) with carrier plate downwards
- Push ring gear (30) over the coupling gear.
- Locate large spring (31).
- Fit largest ball retainer (34) with balls underneath.
- Fit cover (32, inside to the spring).
- Assemble the compression spring (33) with 12 turns.
- Position driver (35) – push it down – and screw on fixed cone (36) to the stop, tightening torque 20 Nm (177 in.lbs.).

- Clamp other axle end (groove for Clickbox is facing downwards).
- Assemble hub shell (6) with a slight counter-clockwise movement.
In case the hub shell jams, position the plastic ring (Fig. 3) correctly. The plastic ring is only fitted to some hub versions.
- Screw brake cone (7) clockwise onto the planetary gear carrier (10) until it stops.
- Insert 3 brake segments (5).
- Turn in friction spring (3) counterclockwise into the lever cone (2) (inlying winding of the spring has to lie against the lever cone) (Fig. 4).
- Insert ball retainer (4) (balls are facing upwards) into lever cone (2): the 3 recesses have to engage into the retaining lugs of the lever cone. Slightly turn ball retainer to prevent it from falling off.
- Fit lever cone onto hub shell: the retaining lugs of the lever cone have to engage into the openings between the brake segments. Make sure that lever cone engages while turning it back and forth slightly.
- Screw on locknuts (1), adjust bearing so that there is no play and lock nuts together with 15 – 20 Nm (133 – 177in.lbs.).

Caution:

Check that all the brake system components are functioning properly!

Advice:

Dismantling and reassembly of hub version without brake should be carried out in the same way.

Differences: Instead of brake segments / cone a click-and-pawl carrier is installed on the planetary gear carrier.

SRAM® S7 MAINTENANCE

5

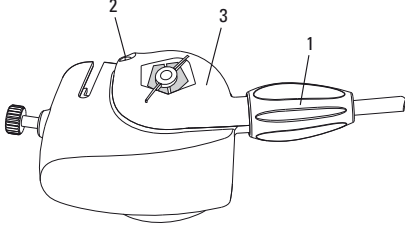

6

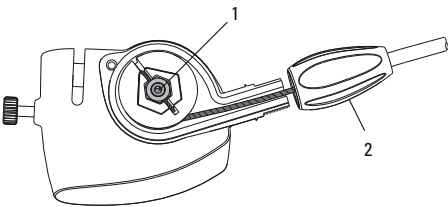

7

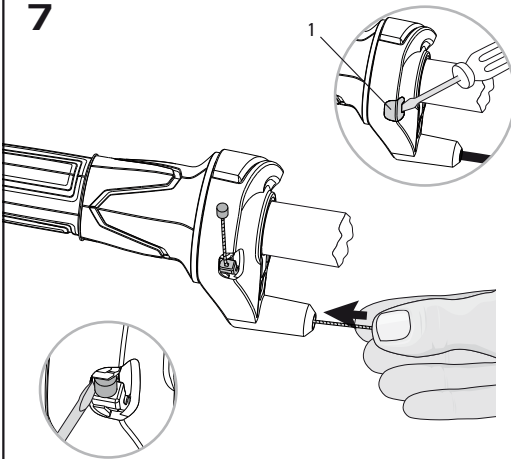

8

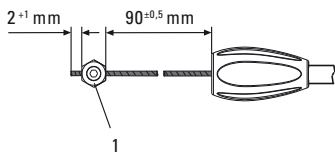

9

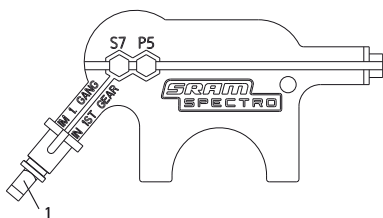

CHANGING THE SHIFT CABLE

Advice:

Always use new, high-quality cables and compressionless cable housings with end caps.

- Turn the twist shifter to 1st gear.

Advice:

Do not remove the Clickbox from the axle end.

- Unscrew the barrel adjuster (1, Fig. 5) completely. Unscrew the cover screw (2), brush aside the barrel adjuster (1) and remove the cover (3).
- Withdraw the shifter cable and clamping bolt (1, Fig. 6) upwards, loosen the clamp screw with a 2.5 mm Allen key and pull the clamping piece from the cable.
- Remove and discard the old cable housing.
- Remove the cap (1, Fig. 7) from the shifter. The nipple of the inner cable is now visible.

- Push or pull the old inner cable (Fig. 7) out of the shifter, e.g. using a small screwdriver.
- Guide the new inner cable into the cable inlet, through the shifter and the new cable housing. Pull the cable tight.
- Insert the cap in the shifter.

- Position clamping bolt (1, Fig. 8) at a distance of 90 mm.

Advice:

For positioning the clamping bolt use adjust gauge (Fig. 9) (Part. No. 65 0324 107 000).

Tighten the clamping screw with a 2.5 mm Allen key. Tightening torque 1.5 Nm (13 in.lbs.).

Cut off the cable end to 2 – 3 mm.

- Locate clamping bolt (1, Fig. 6) and place shifter cable around the carrier cylinder (counter-clockwise winding).
- Position the cover (3, Fig. 5) and tighten up with the cover screw (2). Torque 0.35 – 0.45 Nm (3.1 – 4.0 in.lbs.). Screw in the barrel adjuster (1) completely.

Advice:

- If you want to remove the Clickbox from the axle end for changing the cable, do as follows:

- Place shifter in gear position "1".
- Loosen the knurled screw and pull the Clickbox off the axle.
- Now it's essential to push the end (1, Fig. 9) of the adjust gauge completely into the Clickbox and tighten up the knurled bolt (so that you maintain the initial tension of the spring inside the Clickbox).

- Change cable as per description above.

- If you remove the Clickbox from the axle and change the cable without using the end of the adjust gauge, then you will lose the initial tension of the spring inside the Clickbox. In this case you must assemble the cable by placing it around the carrier cylinder with an additional winding (Fig. 6).
- Adjust the gears as described on page 71.

MAINTENANCE / LUBRICATION

Caution:

The rear wheel hub is provided with permanent lubrication and is almost maintenance-free under normal conditions. If the coaster brake is loaded excessively its effect can be too strong, the hub may lock. In such a case the 3 brake segments must be lubricated only with SRAM special grease (Part No. 0369 135 200/ ...201). Renew brake segments when rhombic pattern is worn out.

Cleaning of parts:

- All parts – except for the planetary gear carrier – can be degreased in a cleaning bath.
- The planetary gear carrier only needs to be cleaned on the outside with a brush so as not to degrease the planetary gear bearing.

Caution:

The rear wheel hub is not completely waterproof. However, do not use water under pressure (such as pressure washers or water jets) for cleaning to prevent malfunctions due to water penetration.

Lubrication of parts:

Use only SRAM special grease, part no. 0369 135 200 / ... 201.

Lubricate ball retainers and ball tracks only with SRAM Ball Bearing Grease. Part no. 0369.001.015.

- To lubricate the bearing points on the planetary gear sets, position the planetary gear carrier on its crown and apply 2 – 3 drops of oil to the bearing bolts – at the same time turning the planetary gears so that the bearing points are completely wet. Oil axle through the axle bore and axle slot, apply a thin coating of grease to the outside.
- Oil the inside of the sun gears, grease the outside teeth (fill the gaps in the teeth).
- Oil outside teeth and carrier plate on the coupling gear and lightly grease the borehole from right and left.
- Do not apply grease to ring gear but just oil the pawl pockets.
- Slightly grease the actuation ramps of the planetary gear carrier.
- Apply grease all around the seat area of the friction spring. Oil the pawl pockets.
- Spread grease on the complete surfaces inside and outside of the 3 brake segments.
- Regrease ball retainer and insert into lever cone, slightly grease cone surface of the lever cone.
- Line ball bearing running tracks and brake cylinder in hub shell with grease.

TROUBLESHOOTING

Problem	Cause	Remedy
Shifting difficulties	Damaged control cable	Replace control cable
	Incorrect gear setting	Adjust shift system
	To much additional axle attachments between hub and axle nut	Beginning of axle thread must be visible in front of the axle nut
Pedals are carried forward when free-wheeling	Bearings set too tight	Re-adjust bearings
	Loose lock nuts	Tighten lock nuts (15 – 20 Nm)
	Chain is over-tensioned	Reduce chain tension
Hub locks when braking (coaster brake)	Brake segments has run dry	Wash out hub sleeve, repolish and relubricate brake cylinder, renew brake segments
Coaster brake without function	Incorrect mounted friction spring (3, Fig. 1 / Page 72)	Fit friction spring in correct way

SRAM® P5 TECHNICAL DATA / ASSEMBLY REQUIREMENTS

P5

Version SRAM P5 Cargo:
see page 85.

Caution:
Not suitable for tandems, transport bicycles and similar.

- Cycle frame:**
- Dropouts must be parallel.
 - Slot width at rear dropout 10^{+0.5} mm.
 - The strength must be such that with a maximum braking torque of 250 Nm (2200 in.lbs.) on the rear wheel no residual deformation can occur on the rear structure.

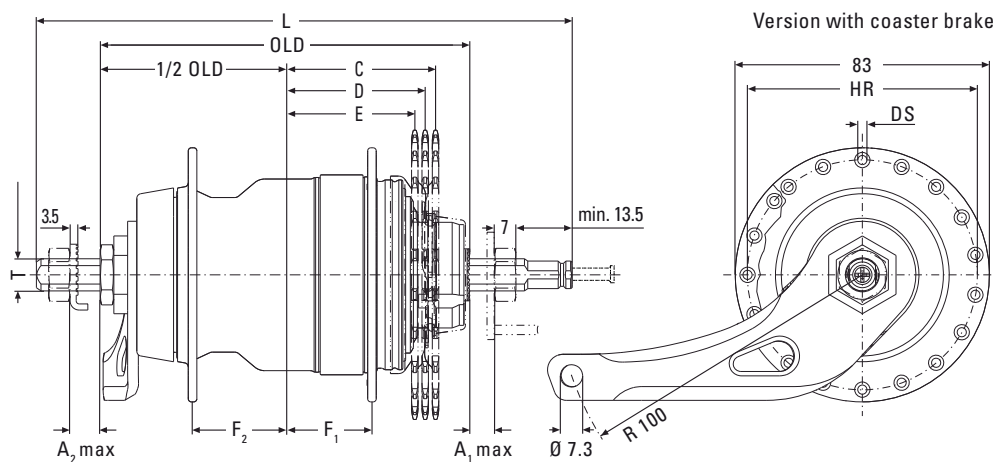

GEAR HUBS

		SRAM P5 with coaster brake	SRAM P5 without brake
	Type	MH 5215	MH 5205
	Brake	With coaster brake	Without brake
Axle	Over Locknut Dim., OLD	122 mm	122 mm
	Length, L	175 mm	175 mm
	Ends Diameter, T	FG 10.5 FG 10.5 toothed cone	FG 10.5
	Dropout Width Dim.	A ₁ max. = 12.5 mm / A ₂ max. = 11.5 mm	A ₁ max. = 12.5 mm / A ₂ max. = 10.5 mm
Spoke	Holes	36	36
	Hole Diameter, DS	3,0 mm	3,0 mm
	Hole Ref. ø, HR	75 mm	75 mm
	Flange Dist. to 1/2 OLD	F ₁ = 28.5 mm / F ₂ = 29.5 mm	F ₁ = 29 mm / F ₂ = 29 mm
Gear Hub Ratio	Totally	251 %	←
	Speed 1	0,633	←
	Speed 2	0,781	←
	Speed 3	1,000	←
	Speed 4	1,281	←
	Speed 5	1,579	←
Chain	Usable Dimensions	1/2" x 1/8" or 1/2" x 3/32"	1/2" x 1/8" or 1/2" x 3/32"
	Line, C/D/E	C = 49 mm / D = 45.5 / E = 43 mm	C = 49 mm / D = 45.5 mm / E = 43 mm
Compatibility	Ratio	24", 26", 28" = 1.8 – 1.9 / 20" = 1.8 – 2.0	min. 1.8
	Sprocket	16 – 24 Teeth (outward offset - Chain Line C) / 16 – 18 Teeth (straight - Chain Line D) / 18 – 24 Teeth (inward offset - Chain Line E)	
	Shifter	SRAM Grip 5	←
	Clickbox	Clickbox P5	←
	Tandem	Not suitable for tandems, transport bicycles or similar	
Finish	Weight	1495 g	1330 g
	Hub Shell Material	Steel	Steel
	Finish	Matt Chrome Plated	Matt Chrome Plated

SRAM® P5 TECHNICAL DATA / ASSEMBLY REQUIREMENTS

SHIFTER

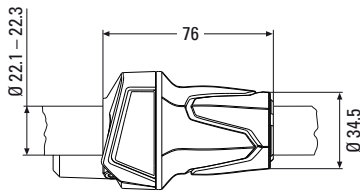

SHIFTER

SRAM Grip 5	
Shifter Type	Twist Shifter mit Clickbox
Cable Length	1500 mm 1600 mm 1700 mm 1800 mm 1900 mm
Gear Indication	Window
Clamping Diameter	22.1 – 22.3 mm
Straight handlebar ends	Minimum necessary length for shifter and handlebar grip = 150 mm
Length of shifter	76 mm
Weight	N/A
Housing	Glass filled PA
Grip	PP
Grip Cover	Thermoplastic elastomer, Overmolded
Clamping Collar	Aluminum

SRAM P5 ASSEMBLY

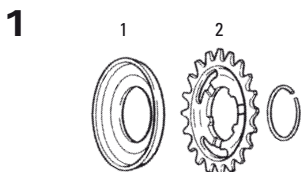

ASSEMBLY HUB

- Lace the wheel as normal. See spoke length table.
 - Place the dust cap (1, Fig. 1) and sprocket (2) on the driver.
- Advice:**
When fitting a straight sprocket (not an offset version), the beadings of the sprocket must lie against the dust cap.

- Push sprocket circlip (3, Fig. 2) onto the cone of tool sleeve (4). Place tool sleeve with large diameter on the driver.
- Push the spring end of sliding sleeve (5) of the tool over the tool sleeve. Thrust sliding sleeve in direction (6), this forces circlip into the recess of the driver.
- Remove tool and check that the circlip is seated correctly.

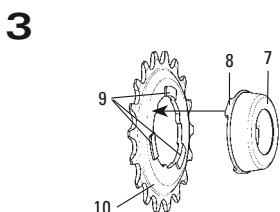
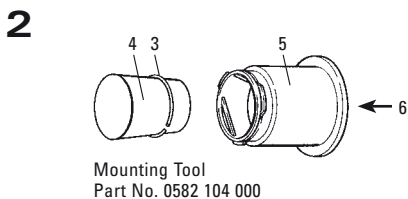

Spoke length table:

Tire Size	Cross	Length
47-406	20" x 1.75 x 2	3 x 181 mm
37-490	22" x 1 3/8	3 x 225 mm
47-507	24" x 1.75 x 2	3 x 232 mm
37-540	24" x 1 3/8	3 x 251 mm
47-559	26" x 1.75 x 2	3 x 259 mm
37-590	26" x 1 3/8	3 x 275 mm
47-622	28" x 1.75	3 x 289 mm
37-622	28" x 1 3/8 x 1 5/8	3 x 289 mm
28-622	28" x 1 1/8	3 x 289 mm
32-622	28" x 1 5/8 x 1 1/4	3 x 289 mm
28-630	27" x 1 1/4 fifty	3 x 294 mm
32-630	27" x 1 1/4	3 x 294 mm

Spoke lengths are approximate values. They must be checked through lacing attempts and adjusted accordingly.

4

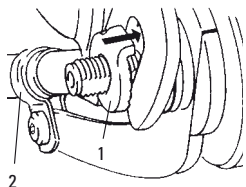

5

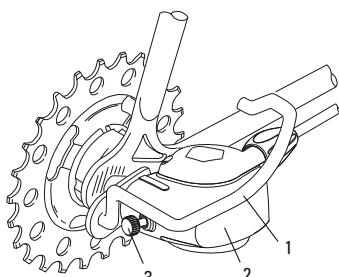

6

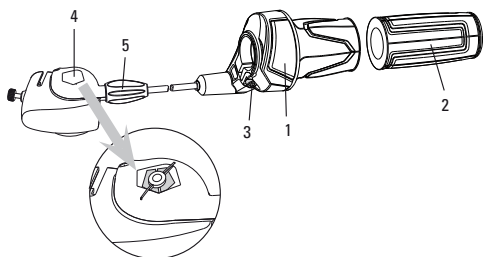

7

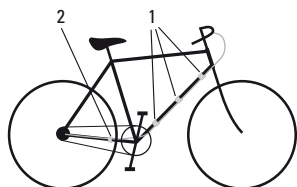

8

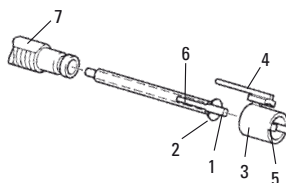

- Turn dust cap (7, Fig. 3) until the three lugs (8) are between the three beads (9) on the sprocket (10).
- Position dust cap and push towards sprocket until it is felt to lock into place.
- Placing the wheel in the rear frame.
- Fit new retaining washer (3,5 mm thick) on left axle end (1, Fig. 4). The serrations must bear against the dropout and the lug must engage in the dropout slot.
- On the sprocket side fit the protective bracket (1, Fig. 5) directly below the axle nut. Tightening torque on axle nuts 30 – 40 Nm (266 – 350 in.lbs.).
- Mount the brake lever using a suitable frame clamp (2, Fig. 4).

Caution:

Mount the brake lever between the two straps of the frame clamp.

The clamp must be seated on the frame without play.

Use a self-locking nut! Tightening torque: 2 – 3 Nm (18 – 27 in.lbs.).

Advice:

- If a different protective bracket (1, Fig. 5) is used the thickness of the attachment plate must be max. 3 mm.
- Do not use additional washers.
- At least the beginning of the axle thread must be visible in front of the axle nut.

Caution:

Check that all the brake system components are functioning properly!

ASSEMBLY SHIFTER

Advice:

- When choosing cable housing lengths, be sure to allow enough housing for an extreme turn of the handlebars in both directions.
- Note also, that different stem lengths and handlebar positions effects cable housing length.

- Slide the shifter (1, Fig. 6) onto the handlebar.
- Slide the handlebar grip (2) onto the handlebar.

Caution:

Never use lubricants or solvents when fitting handlebar grips. They have a safety function and must not come free from the handlebar.

- Place the shifter on the handlebar grip and position so that you can use it comfortably. Tighten the clamping bolt (3). 3 mm Allen key, torque 3.5 – 4 Nm (31 – 35 in.lbs.).

Caution:

- Check that shifter and brake lever can be easily operated (if necessary, realign).
- Never ride without handlebar grips. The turning grip of the twist shifter could become loose. This can result in severe injuries.

- When fitting the cable avoid small radius. Attach the cable 3 times to the down tube (1, Fig. 7).
 - Last attachment point is on the lower rear wheel fork (2, Fig. 7) immediately behind the chain wheel.
- Cable housing must be movable inside attachment.**

INSTALLING CLICKBOX

- Insert shift rod (1, Fig. 8) in shift tube (2) (oil parts lightly) and then push into axle bore as far as the stop. Turn slot (6) in shift tube to a position where it is easily visible.
- Push locating sleeve (3) with guiding rib (4) to the front onto the hub axle – making sure that the internal lug (5) is guided in the slot (6) of the shift tube until it can be felt – and heard – to engage.
- Turn locating sleeve on the axle until the guiding rib (4) is facing roughly upwards.
- Place shifter in gear position “2”.
- Push on Clickbox (2, Fig. 5) to the stop on the hub axle. The guiding rib (4, Fig. 8) of the locating sleeve thereby engages in the slot in the housing. In the end position tighten up the knurled bolt (3, Fig. 5) by hand (0.3 Nm / 2.7 in.lbs.).

ADJUSTMENT

- Be sure to reset rotational shifter from 4th to 3th gear.
- Match up the marks in the Clickbox viewing window (4, Fig. 6) by turning the barrel adjuster (5).

Caution:

Check that all the brake system components are functioning properly!

SRAM® P5 MAINTENANCE

1

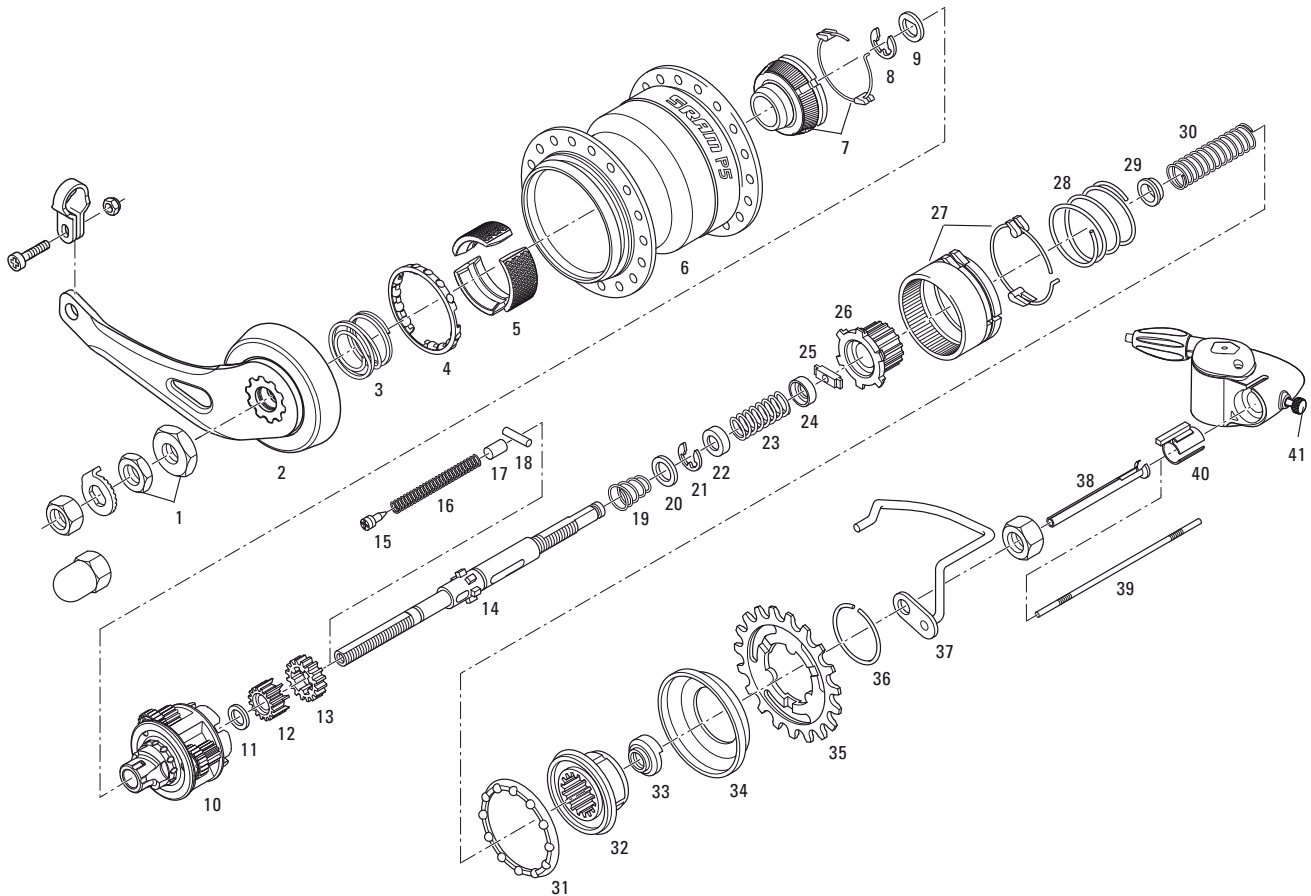

2

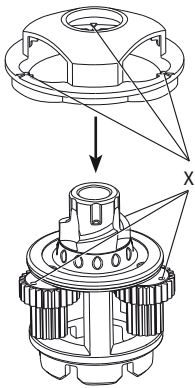

SRAM P5 mounting aid
Part No. 65 0524 300 000

3

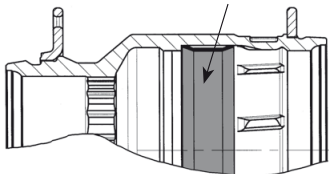

SERVICE

To maintain optimal performance and durability of your components, periodic maintenance is required. We recommend that you have your components serviced every 2 year or 5000 km by a qualified bicycle mechanic.

REMOVE WHEEL

- Place shifter in gear position "2".
- Loosen the knurled screw (41, **Fig. 1**) and pull the Clickbox off the axle.
- Disengage the red location sleeve (40) and pull it off.
- Remove shift rod (39) and shift tube (38) out of the axle bore.
- Remove wheel.

DISMANTLING HUB

see **Fig. 1**

- Remove circlip (36), sprocket (35) and dust cap (34).
- Clamp hub with sprocket side facing downwards with the two axle flats.
- Unscrew both locknuts (1).
- While turning clockwise, remove lever cone (2) with friction spring (3) and ball retainer (4).

- Take out 3 brake segments (5).
- Withdraw hub sleeve (6) upwards.
- Remove brake cone (7).
- Remove retaining washer (8), thrust washer (9).
- Remove planetary gear carrier (10) and thrust washer (11).
- Clamp other axle end.
- Unscrew fixed cone (33).
- Remove driver (32), compression spring (30), large compression spring (28) and ball retainer (31).
- Withdraw gear ring (27) and coupling gear (26) and then remove cover (29) from the coupling gear.
- Take out thrust block (25), (to do this compress the spring). Remove spring (23) and the two covers (24/22).
- Dismantle retaining washer (21), washer (20), conical compression spring (19), and the large sun gear (13). Clamp other axle end (thrust block visible).
- Unscrew grub screw (15) – Dismantle spring (16), guide bolt (17) and thrust block (18).
- Remove small sun gear (12).

4

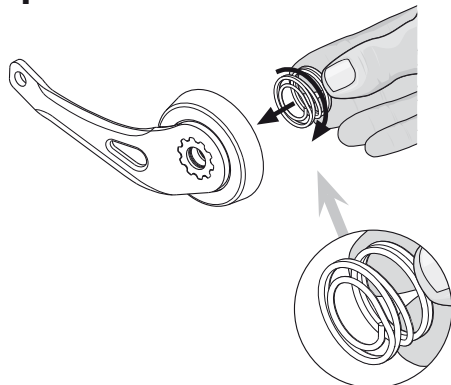

REASSEMBLY HUB

see Fig. 1

Lubrication see "MAINTENANCE / LUBRICATION".

- Clamp axle with internal thread upwards.
- Position small sun gear (12) with crown gears to the front.
- Position thrust block (18) in the slotted hole (is laterally guided when the sun gear is screwed in).
- Locate bolt (17), then screw in grub screw (15) until it is flush with the axle.
- Reclamp axle. Fit large sun gear (13) (it is the same both sides). Position conical compression spring (19), with the large diameter first. Press spring together and fit washer (20) and retaining washer (21).
- Assemble cover (22), compression spring with 7 turns (23) and the second cover (24, insides to the spring).
- Compress spring and position thrust block (25) (it is the same both sides) in the center of the slotted hole.
- Position coupling gear (26) with carrier plate facing downwards.
- Fit cover (29, inside to the spring) for compression spring.
- Position gear ring (27) over the teeth of the coupling gear.
- Place ball retainer (31), with balls below on the gear ring.
- Position large compression spring (28) on gear ring.
- Mount compression spring with 13 turns (30) on the axle. (Is supported in the coupling wheel by the cover).
- Locate driver (32), press it down and screw on fixed cone (33) as far as the stop. Tightening torque 20 Nm.
- Clamp other axle end.
- Push on thrust washer (11) and fit planetary gear carrier (10). In doing this: Position mounting aid (Fig. 2) on the planetary gear carrier so that the (X) markings on the three planetary gears match with the mounting aid.
- Insert planetary gear carrier, place thrust washer (8) on it and mount retaining washer (9) in recess.

Now remove the mounting aid.

Advice:

If the gears are not accurately installed the hub may be tight to move.

This could lead to damage to the gear-wheels in operation.

- Assemble hub shell (6) with a slight counter-clockwise movement. In case the hub shell jams, position the plastic ring (Fig. 3) correctly. The plastic ring is only fitted to some hub versions.

- Screw brake cone (7) clockwise onto the planetary gear carrier (10) until it stops.
- Insert 3 brake segments (5).
- Turn in friction spring (3) counterclockwise into the lever cone (2) (inlying winding of the spring has to lie against the lever cone) (Fig. 4).
- Insert ball retainer (4) (balls are facing upwards) into lever cone (2): the 3 recesses have to engage into the retaining lugs of the lever cone. Slightly turn ball retainer to prevent it from falling off.
- Fit lever cone onto hub shell: the retaining lugs of the lever cone have to engage into the openings between the brake segments. Make sure that lever cone engages while turning back and forth slightly.
- Screw on locknuts (1), adjust bearing so that there is no play and lock nuts together with 15 – 20 Nm (133 – 177in. lbs.).

Caution:

Check that all the brake system components are functioning properly!

Advice:

Dismantling and reassembly of hub version without brake should be carried out in the same way.

Differences: Instead of brake segments / cone a click-and-pawl carrier is installed on the planetary gear carrier.

SRAM® P5 MAINTENANCE

5

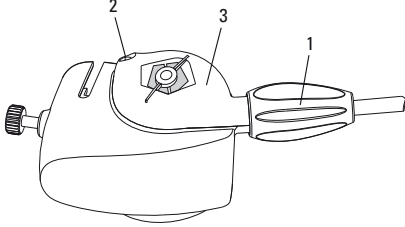

6

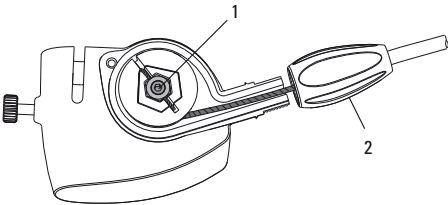

7

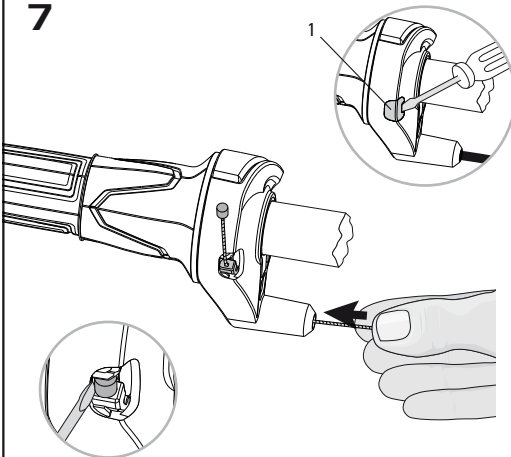

8

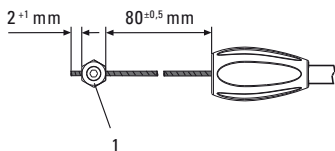

9

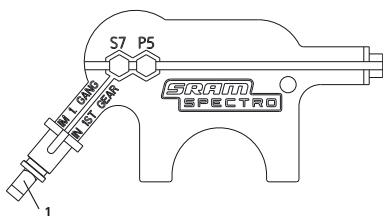

CHANGING THE SHIFT CABLE

Advice:

Always use new, high-quality cables and compressionless cable housings with end caps.

- Turn the twist shifter to 1st gear.

Advice:

Do not remove the Clickbox from the axle end.

- Unscrew the barrel adjuster (1, Fig. 5) completely. Unscrew the cover screw (2), brush aside the barrel adjuster (1) and remove the cover (3).
- Withdraw the shifter cable and clamping bolt (1, Fig. 6) upwards, loosen the clamp screw with a 2.5 mm Allen key and pull the clamping piece from the cable.
- Remove and discard the old cable housing.
- Remove the cap (1, Fig. 7) from the shifter. The nipple of the inner cable is now visible.

- Push or pull the old inner cable (Fig. 7) out of the shifter, e.g. using a small screwdriver.
- Guide the new inner cable into the cable inlet, through the shifter and the new cable housing. Pull the cable tight.
- Insert the cap in the shifter.

- Position clamping bolt (1, Fig. 8) at a distance of 80 mm.

Advice:

For positioning the clamping bolt use adjust gauge (Fig. 9) (Part. No. 65 0324 107 000).

Tighten the clamping screw with a 2.5 mm Allen key. Tightening torque 1.5 Nm (13 in.lbs.).

Cut off the cable end to 2 – 3 mm.

- Locate clamping bolt (1, Fig. 6) and place shifter cable around the carrier cylinder (counter-clockwise winding).
- Position the cover (3, Fig. 5) and tighten up with the cover screw (2). Torque 0.35 – 0.45 Nm (3.1 – 4.0 in.lbs.). Screw in the barrel adjuster (1) completely.

Advice:

- If you want to remove the Clickbox from the axle end for changing the cable, do as follows:

- Place shifter in gear position "1".
- Loosen the knurled screw and pull the Clickbox off the axle.
- Now it's essential to push the end (1, Fig. 9) of the adjust gauge completely into the Clickbox and tighten up the knurled bolt (so that you maintain the initial tension of the spring inside the Clickbox).
- Change cable as per description above.

- If you remove the Clickbox from the axle and change the cable without using the end of the adjust gauge, then you will lose the initial tension of the spring inside the Clickbox. In this case you must assemble the cable by placing it around the carrier cylinder with an additional winding (Fig. 6).
- Adjust the gears as described on page 67.

MAINTENANCE / LUBRICATION

Caution:

The rear wheel hub is provided with permanent lubrication and is almost maintenance-free under normal conditions. If the coaster brake is loaded excessively its effect can be too strong, the hub may lock. In such a case the 3 brake segments must be lubricated only with SRAM special grease (Part No. 0369 135 200/ ...201). Renew brake segments when rhombic pattern is worn out.

Cleaning of parts:

- All parts – except for the planetary gear carrier – can be degreased in a cleaning bath.
- The planetary gear carrier only needs to be cleaned on the outside with a brush so as not to degrease the planetary gear bearing.

Caution:

The rear wheel hub is not completely waterproof. However, do not use water under pressure (such as pressure washers or water jets) for cleaning to prevent malfunctions due to water penetration.

Lubrication of parts:

Use only SRAM special grease, part no. 0369 135 200 / ... 201.

Lubricate ball retainers and ball tracks only with SRAM Ball Bearing Grease. Part no. 0369.001.015.

- To lubricate the bearing points on the planetary gear sets, position the planetary gear carrier on its crown and apply 2 – 3 drops of oil to the bearing bolts – at the same time turning the planetary gears so that the bearing points are completely wet. Oil axle through the axle bore and axle slot, apply a thin coating of grease to the outside.
- Oil the inside of the sun gears, grease the outside teeth (fill the gaps in the teeth).
- Oil outside teeth and carrier plate on the coupling gear and lightly grease the borehole from right and left.
- Do not apply grease to ring gear but just oil the pawl pockets.
- Slightly grease the actuation ramps of the planetary gear carrier.
- Apply grease all around the seat area of the friction spring. Oil the pawl pockets.
- Spread grease on the complete surfaces inside and outside of the 3 brake segments.
- Regrease ball retainer and insert into lever cone, slightly grease cone surface of the lever cone.
- Line ball bearing running tracks and brake cylinder in hub shell with grease.

TROUBLESHOOTING

Problem	Cause	Remedy
Shifting difficulties	Damaged control cable	Replace control cable
	Incorrect gear setting	Adjust shift system
	To much additional axle attachments between hub and axle nut	Beginning of axle thread must be visible in front of the axle nut
Pedals are carried forward when free-wheeling	Bearings set too tight	Re-adjust bearings
	Loose lock nuts	Tighten lock nuts (15 – 20 Nm)
	Chain is over-tensioned	Reduce chain tension
Hub locks when braking (coaster brake)	Brake segments has run dry	Wash out hub sleeve, repolish and relubricate brake cylinder, renew brake segments
Coaster brake without function	Incorrect mounted friction spring (3, Fig. 1 / Page 68)	Fit friction spring in correct way

SRAM® P5 CARGO

TECHNICAL DATA / ASSEMBLY REQUIREMENTS



Caution:

The SRAM P5 Cargo is suitable for tandems, transport bicycles and similar. An additional external rear brake is necessary due to the high load.

Tolerable stress:

Axle load: max. 120 kilograms
Torque/driver body: max. 85 Nm (750 in.lbs.), no continuous stress.

Identification SRAM P5 Cargo:

Yellow grub screw inside the axle end.

Version SRAM P5 for normal bikes:

see page 77.

Cycle frame:

- Dropouts must be parallel.
- Slot width at rear dropout 10^{-0.5} mm.
- The strength must be such that with a maximum braking torque of 250 Nm (2200 in.lbs.) on the rear wheel no residual deformation can occur on the rear structure.

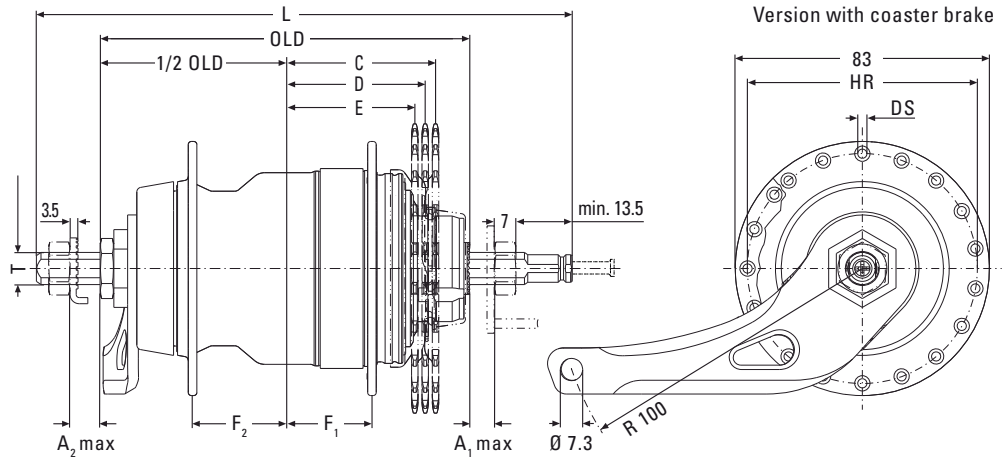

GEAR HUBS

	SRAM P5 Cargo with coaster brake	SRAM P5 Cargo with drum brake	SRAM P5 Cargo disc brake compatible
Typ	MH 5215 Cargo	MH 5225 Cargo	—
Brake	With coaster brake	With drum brake – Version „D“	Adaptor for disc brake
Over Locknut Dim., OLD	122 mm	126 mm	125 mm
Length, L	175 mm	179 mm	179 mm
Ends Diameter, T	FG 10.5 toothed cone	FG 10.5	FG 10.5
Dropout Width Dim.	A ₁ max. = 12.5 mm / A ₂ max. = 11.5 mm	A ₁ max. = 12.5 mm / A ₂ max. = 12.5 mm	A ₁ max. = 12.5 mm / A ₂ max. = 11.5 mm
Holes	36	36	36
Hole Diameter, DS	3.0 mm	2.9 mm	3.0 mm
Hole Ref. ø, HR	75 mm	89 mm	75 mm
Flange Dist. to 1/2 OLD	F ₁ = 28.5 mm / F ₂ = 29.5 mm	F ₁ = 30.5 mm / F ₂ = 29.5 mm	F ₁ = 28.5 mm / F ₂ = 29.5 mm
Gear Hub Ratio	Totally 224 % Speed 1 0,667 Speed 2 0,778 Speed 3 1,000 Speed 4 1,286 Speed 5 1,500	Gear steps ← ← ← ← ←	← ← ← ← ←
Chain	Usable Dimensions 1/2" x 1/8" or 1/2" x 3/32" Line, C/D/E C = 49 mm / D = 45.5 mm / E = 43 mm Ratio 24", 26", 28" = 1.8 – 1.9 / 20" = 1.8 – 2.0	1/2" x 1/8" or 1/2" x 3/32" C = 51.5 mm / D = 48.5 mm / E = 45.5 mm min. 1.8	1/2" x 1/8" or 1/2" x 3/32" C = 50 mm / D = 47 mm / E = 44 mm min. 1.8
Compatibility	Sprocket 16 – 24 Teeth (outward offset - Chain Line C) / 16 – 18 Teeth (straight - Chain Line D) / 18 – 24 Teeth (inward offset - Chain Line E) Shifter SRAM Grip 5 Clickbox Clickbox P5 Scheibenbremse — Hand Brake Lever — Tandem Suitable for tandems, transport bicycles or similar	← ← ← — see page 87	← ← 6 holes Disc brake compatible ←
Weight	1495 g	1536 g	1390 g
Hub Shell Material	Steel	Aluminum	Steel
Finish	Matt Chrome Plated	Clear Coat	Matt Chrome Plated

SRAM® P5 CARGO

TECHNICAL DATA / ASSEMBLY REQUIREMENTS

SHIFTER

SRAM Grip 5 (Drawing see Page 66)

Design	Shifter Type	Twist Shifter mit Clickbox				
	Cable Length	1500 mm	1600 mm	1700 mm	1800 mm	1900 mm
	Gear Indication	Window				
	Clamping Diameter	22.1 – 22.3 mm				
	Handlebar, Straight Area	Minimum necessary length for shifter and handlebar grip = 150 mm				
	Length of shifter	76 mm				
	Weight	N/A				
	Housing	Glass filled PA				
	Grip	PP				
	Grip Cover	Thermoplastic elastomer, Overmolded				
	Clamping Collar	Aluminum				

SRAM P5 CARGO MONTAGE

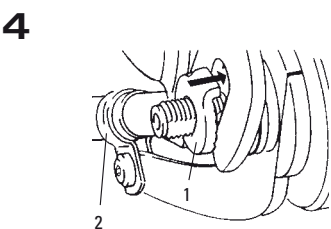
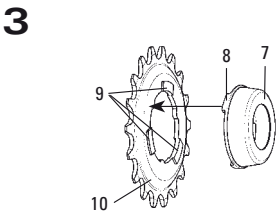
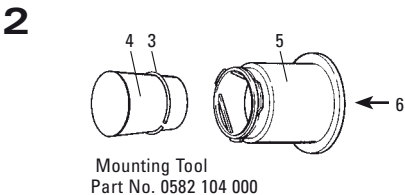
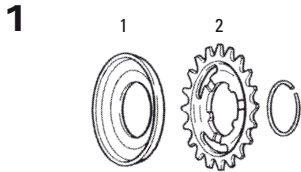

ASSEMBLY HUB

- Lace the wheel as normal. See spoke length table.
- Place the dust cap (1, Fig. 1) and sprocket (2) on the driver.

Advice:

When fitting a straight sprocket (not an offset version), the beadings of the sprocket must lie against the dust cap.

- Push sprocket circlip (3, Fig. 2) onto the cone of tool sleeve (4). Place tool sleeve with large diameter on the driver.
- Push the spring end of sliding sleeve (5) of the tool over the tool sleeve. Thrust sliding sleeve in direction (6), this forces circlip into the recess of the driver.
- Remove tool and check that the circlip is seated correctly.

- Turn dust cap (7, Fig. 3) until the three lugs (8) are between the three beads (9) on the sprocket (10).

- Position dust cap and push towards sprocket until it is felt to lock into place.

- Hub versions for Disc Brake:

Advice:

Read and observe the corresponding technical documentation for assembling the disc of the disc brake.

Caution:

Plane faces of the hub and the disc and the threaded holes of the hub must be clean and free from oily and greasy substances.

- Placing the wheel in the rear frame.
- Fit new retaining washer (3,5 mm thick) on left axle end (1, Fig. 4). The serrations must bear against the dropout and the lug must engage in the dropout slot.

Spoke length table:

Tire Size		Cross	Length MH 5215	Length MH 5225
47-406	20" x 1.75 x 2	3 x	181 mm	179 mm
37-490	22" x 1 3/8	3 x	225 mm	222 mm
47-507	24" x 1.75 x 2	3 x	232 mm	229 mm
37-540	24" x 1 3/8	3 x	251 mm	248 mm
47-559	26" x 1.75 x 2	3 x	259 mm	256 mm
37-590	26" x 1 3/8	3 x	275 mm	272 mm
47-622	28" x 1.75	3 x	289 mm	286 mm
37-622	28" x 1 3/8 x 1 5/8	3 x	289 mm	286 mm
28-622	28" x 1 1/8	3 x	289 mm	286 mm
32-622	28" x 1 5/8 x 1 1/4	3 x	289 mm	286 mm
28-630	27" x 1 1/4 fifty	3 x	294 mm	291 mm
32-630	27" x 1 1/4	3 x	294 mm	291 mm

Spoke lengths are approximate values. They must be checked through lacing attempts and adjusted accordingly.

5

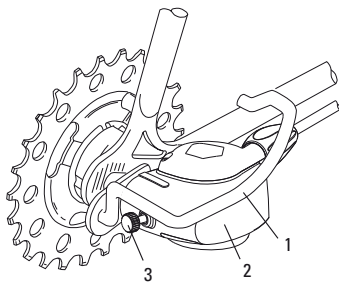

6

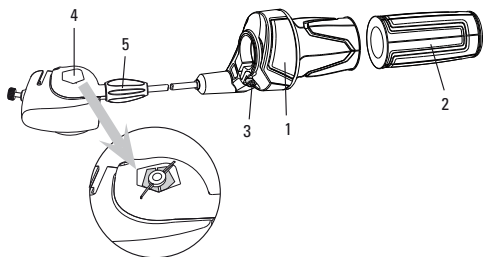

7

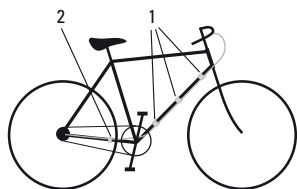

8

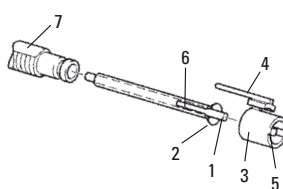

9

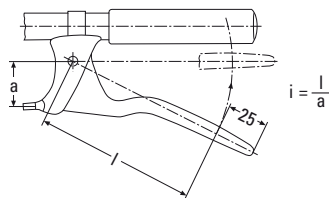

10

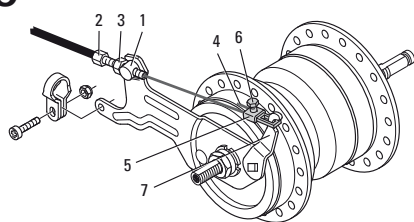

- On the sprocket side fit the protective bracket (1, Fig. 5) directly below the axle nut. Tightening torque on axle nuts 30 – 40 Nm (266 – 350 in.lbs.).

- Mount the brake lever using a suitable frame clamp (2, Fig. 4 resp. Fig. 10).

Caution:

Mount the brake lever between the two straps of the frame clamp.

The clamp must be seated on the frame without play.

Use a self-locking nut! Tightening torque: 2 – 3 Nm (18 – 27 in.lbs.).

Advice:

- If a different protective bracket (1, Fig. 5) is used the thickness of the attachment plate must be max. 3 mm.
- Do not use additional washers.
- At least the beginning of the axle thread must be visible in front of the axle nut.

Caution:

Check that all the brake system components are functioning properly!

ASSEMBLY SHIFTER

Advice:

- When choosing cable housing lengths, be sure to allow enough housing for an extreme turn of the handlebars in both directions.
- Note also, that different stem lengths and handlebar positions effects cable housing length.

- Slide the shifter (1, Fig. 6) onto the handlebar.
- Slide the handlebar grip (2) onto the handlebar.

Caution:

Never use lubricants or solvents when fitting handlebar grips. They have a safety function and must not come free from the handlebar.

- Place the shifter on the handlebar grip and position so that you can use it comfortably. Tighten the clamping bolt (3). 3 mm Allen key, torque 3.5 – 4 Nm (31 – 35 in.lbs.).

Caution:

- Check that shifter and brake lever can be easily operated (if necessary, realign).
- Never ride without handlebar grips. The turning grip of the twist shifter could become loose. This can result in severe injuries.

- When fitting the cable avoid small radius. Attach the cable 3 times to the down tube (1, Fig. 7).
- Last attachment point is on the lower rear wheel fork (2, Fig. 7) immediately behind the chain wheel.

Cable housing must be movable inside attachment.

INSTALLING CLICKBOX

- Insert shift rod (1, Fig. 8) in shift tube (2) (oil parts lightly) and then push into axle bore as far as the stop. If the shifting rod is sticking up out of the axle end: apply slight pressure on the shift rod with its threaded section and screw inwards in a clockwise direction until it can again be moved axially (valid for older hub versions). Turn slot (6) in shift tube to a position where it is easily visible.
- Push locating sleeve (3) with guiding rib (4) to the front onto the hub axle – making sure that the internal lug (5) is guided in the slot (6) of the shift tube until it can be felt – and heard – to engage.
- Turn locating sleeve on the axle until the guiding rib (4) is facing roughly upwards.
- Place shifter in gear position “2”.
- Push on Clickbox (2, Fig. 5) to the stop on the hub axle. The guiding rib (4, Fig. 8) of the locating sleeve thereby engages in the slot on the housing. In the end position tighten up the knurled bolt (3, Fig. 5) by hand (0.3 Nm / 2.7 in.lbs.).

ADJUSTMENT

- Be sure to reset rotational shifter from 4th to 3rd gear.
- Match up the marks in the Clickbox viewing window (4, Fig. 6) by turning the barrel adjuster (5).

CONNECTING DRUM BRAKE

Caution:

Only use brake levers with a cable moving distance of at least 15 mm and a leverage of “i” = 3.8 – 4.2 (Fig. 9).

- Fit cable stop (1, Fig. 10) with adjusting bolt (2) and nut (3) and insert into the slot on the brake anchor plate.
- Turn adjusting bolt down by approx. 2/3 and route the brake cable from the brake handle.
- Push lower brake cable end through adjusting bolt (2) and insert lower cable housing end into adjusting bolt.
- Thread brake cable end (4) into fork unit (5).
- Tighten screw (6) slightly.
- Attach fork unit to brake lever (7).
- Pull brake cable end taut with pliers so that fork unit can still be attached and removed (important for changing wheel).
- Tighten screw (6).

ADJUSTMENT DRUM BRAKE

- Unscrew adjusting screw (2, Fig. 10) until the brake pads drag lightly.
- Actuate the hand brake lever forcefully several times and then, if necessary, turn the adjusting screw further in just until the wheel starts spinning freely.
- Lock hex nut (3).

Caution:

Check that all the brake system components are functioning properly!

SRAM® P5 CARGO MAINTENANCE

1

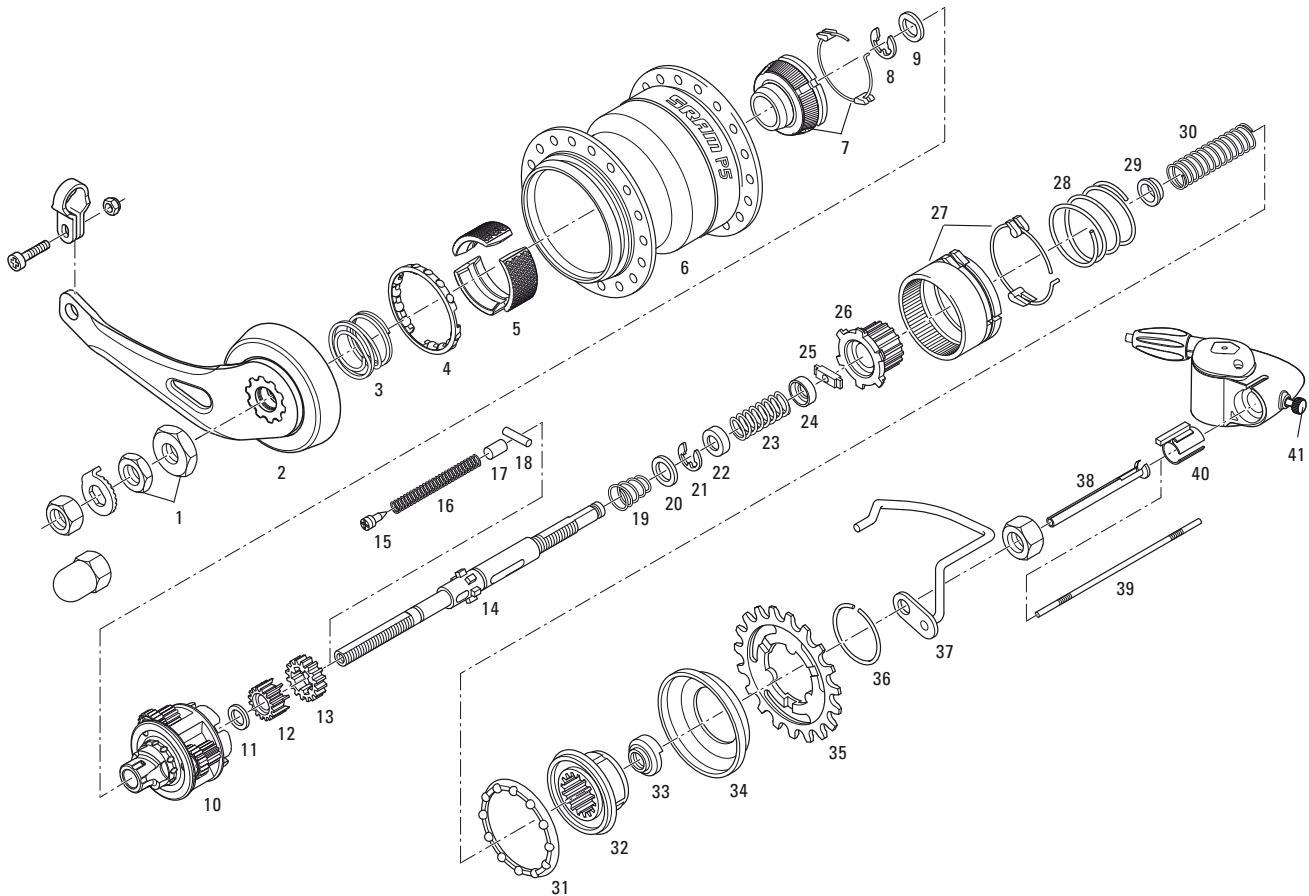

2

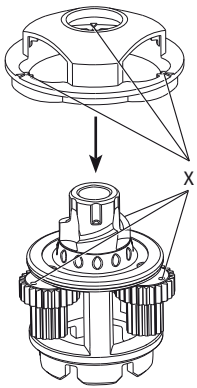

SRAM P5 mounting aid
Part No. 65 0524 300 000

SERVICE

To maintain optimal performance and durability of your components, periodic maintenance is required. We recommend that you have your components serviced every 2 year or 5000 km by a qualified bicycle mechanic.

REMOVE WHEEL

- Place shifter in gear position "2".
- Loosen the knurled screw (41, **Fig. 1**) and pull the Clickbox off the axle.
- Disengage the red location sleeve (40) and pull it off.
- Remove shift rod (39) and shift tube (38) out of the axle bore.
- Remove wheel.

DISMANTLING HUB

see Fig. 1

- Remove circlip (36), sprocket (35) and dust cap (34).
- Clamp hub with sprocket side facing downwards with the two axle flats.
- Unscrew both locknuts (1).
- While turning clockwise, remove lever cone (2) with friction spring (3) and ball retainer (4).

- Take out 3 brake segments (5).
- Withdraw hub sleeve (6) upwards.
- Remove brake cone (7).
- Remove retaining washer (8), thrust washer (9).
- Remove planetary gear carrier (10) and thrust washer (11).
- Clamp other axle end.
- Unscrew fixed cone (33).
- Remove driver (32), compression spring (30), large compression spring (28) and ball retainer (31).
- Withdraw gear ring (27) and coupling gear (26) and then remove cover (29) from the coupling gear.
- Take out thrust block (25), (to do this compress the spring). Remove spring (23) and the two covers (24/22).
- Dismantle retaining washer (21), washer (20), conical compression spring (19), and the large sun gear (13). Clamp other axle end (thrust block visible).
- Unscrew grub screw (15) – Dismantle spring (16), guide bolt (17) and thrust block (18).
- Remove small sun sun gear (12).

3

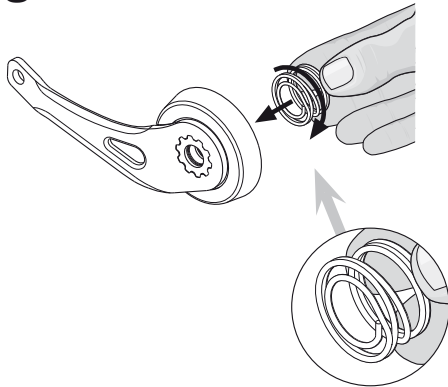

REASSEMBLY HUB

see Fig. 1

Lubrication see "MAINTENANCE / LUBRICATION".

- Clamp axle with internal thread upwards.
- Position small sun gear (12) with crown gears to the front.
- Position thrust block (18) in the slotted hole (is laterally guided when the sun gear is screwed in).
- Locate bolt (17), then spring (16) in the axle and screw in grub screw (15) until it is flush with the axle.
- Reclamp axle. Fit large sun gear (13) (it is the same both sides). Position conical compression spring (19), with the large diameter first. Press spring together and fit washer (20) and retaining washer (21).
- Assemble cover (22), compression spring with 7 turns (23) and the second cover (24, insides to the spring).
- Compress spring and position thrust block (25) (it is the same both sides) in the center of the slotted hole.
- Position coupling gear (26) with carrier plate facing downwards.
- Fit cover (29, inside to the spring) for compression spring.
- Position gear ring (27) over the teeth of the coupling gear.
- Place ball retainer (31), with balls below on the gear ring.
- Position large compression spring (28) on gear ring.
- Mount compression spring with 13 turns (30) on the axle. (Is supported in the coupling wheel by the cover).
- Locate driver (32), press it down and screw on fixed cone (33) as far as the stop. Tightening torque 20 Nm.
- Clamp other axle end.
- Push on thrust washer (11) and fit planetary gear carrier (10). In doing this: Position mounting aid (Fig. 2) on the planetary gear carrier so that the (X) markings on the three planetary gears match with the mounting aid.
- Insert planetary gear carrier, place thrust washer (8) on it and mount retaining washer (9) in recess.

Now remove the mounting aid.

Advice:

If the gears are not accurately installed the hub may be tight to move.

This could lead to damage to the gear-heels in operation.

- Assemble hub shell (6) with a slight counter-clockwise movement.
- Screw brake cone (7) clockwise onto the planetary gear carrier (10) until it stops.
- Insert 3 brake segments (5).

- Turn in friction spring (3) counterclockwise into the lever cone (2) (inlying winding of the spring has to lie against the lever cone) (Fig. 3).
- Insert ball retainer (4) (balls are facing upwards) into lever cone (2): the 3 recesses have to engage into the retaining lugs of the lever cone. Slightly turn ball retainer to prevent it from falling off.
- Fit lever cone onto hub shell: the retaining lugs of the lever cone have to engage into the openings between the brake segments. Make sure that lever cone engages while turning back and forth slightly.
- Screw on locknuts (1), adjust bearing so that there is no play and lock nuts together with 15 – 20 Nm (133 – 177in. lbs.).

Caution:

Check that all the brake system components are functioning properly!

Advice:

Dismantling and reassembly of hub types with drum brake and disc brake should be carried out in the same way.

Differences: Instead of brake segments / cone a click-and-pawl carrier is installed on the planetary gear carrier.

SRAM® P5 CARGO MAINTENANCE

4

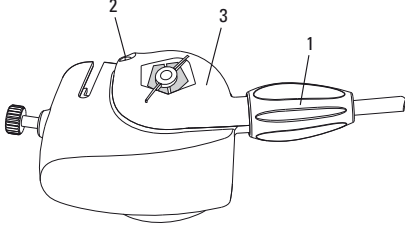

5

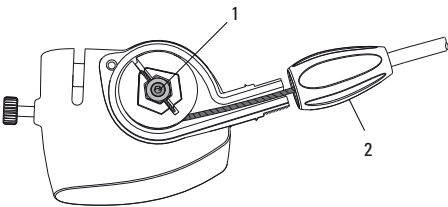

6

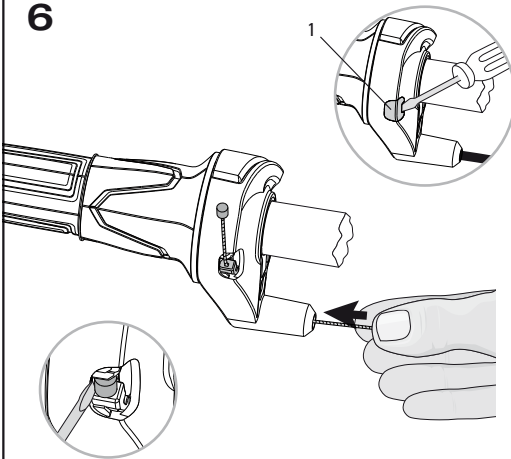

7

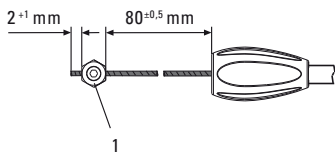

8

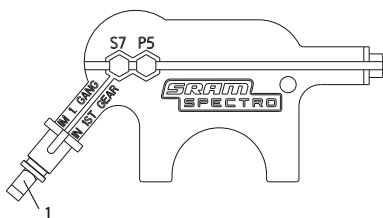

CHANGING THE SHIFT CABLE

Advice:

Always use new, high-quality cables and compressionless cable housings with end caps.

- Turn the twist shifter to 1st gear.

Advice:

Do not remove the Clickbox from the axle end.

- Unscrew the barrel adjuster (1, Fig. 4) completely. Unscrew the cover screw (2), brush aside the barrel adjuster (1) and remove the cover (3).
- Withdraw the shifter cable and clamping bolt (1, Fig. 5) upwards, loosen the clamp screw with a 2.5 mm Allen key and pull the clamping piece from the cable.
- Remove and discard the old cable housing.

- Remove the cap (1, Fig. 6) from the shifter. The nipple of the inner cable is now visible.
- Push or pull the old inner cable (Fig. 6) out of the shifter, e.g. using a small screwdriver.
- Guide the new inner cable into the cable inlet, through the shifter and the new cable housing. Pull the cable tight.
- Insert the cap in the shifter.

- Position clamping bolt (1, Fig. 7) at a distance of 80 mm.

Advice:

For positioning the clamping bolt use adjust gauge (Fig. 9) (Part. No. 65 0324 107 000).

Tighten the clamping screw with a 2.5 mm Allen key. Tightening torque 1.5 Nm (13 in.lbs.).

Cut off the cable end to 2 – 3 mm.

- Locate clamping bolt (1, Fig. 5) and place shifter cable around the carrier cylinder (counter-clockwise winding).
- Position the cover (3, Fig. 4) and tighten up with the cover screw (2). Torque 0.35 – 0.45 Nm (3.1 – 4.0 in.lbs.). Screw in the barrel adjuster (1) completely.

Advice:

- If you want to remove the Clickbox from the axle end for changing the cable, do as follows:

- Place shifter in gear position "1".
- Loosen the knurled screw and pull the Clickbox off the axle.
- Now it's essential to push the end (1, Fig. 8) of the adjust gauge completely into the Clickbox and tighten up the knurled bolt (so that you maintain the initial tension of the spring inside the Clickbox).
- Change cable as per description above.

- If you remove the Clickbox from the axle and change the cable without using the end of the adjust gauge, then you will lose the initial tension of the spring inside the Clickbox. In this case you must assemble the cable by placing it around the carrier cylinder with an additional winding (Fig. 5).

- Adjust the gears as described on page 87.

9

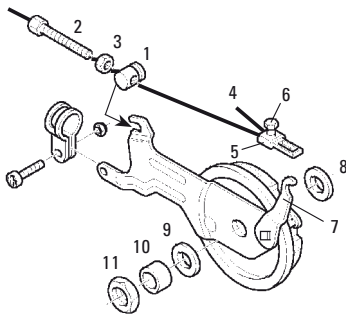

DRUM BRAKE

Install brake anchor plate (or exchange it):

- Place thrust washer (8, **Fig. 9**) over the axle on the adjusting cone and fit complete brake anchor plate. Position washer (9) distance sleeve (10) and screw on locknut (11).
- Push brake lever (7) to the stop and hold it there to center the brake jaws in the brake drum – tighten up locknut with a torque of 15 – 20 Nm (133 – 177 in.lbs.).

ADJUSTMENT DRUM BRAKE

- Unscrew adjusting screw (2, **Fig. 9**) until the brake pads drag lightly.
- Actuate the hand brake lever forcefully several times and then, if necessary, turn the adjusting screw further in just until the wheel starts spinning freely.
- Lock hex nut (3).

Caution:

Check that all the brake system components are functioning properly!

MAINTENANCE / LUBRICATION

Caution:

The rear wheel hub is provided with permanent lubrication and is almost maintenance-free under normal conditions. If the coaster brake is loaded excessively its effect can be too strong, the hub may lock. In such a case the 3 brake segments must be lubricated only with SRAM special grease (Part No. 0369 135 200/ ...201). Renew brake segments when rhombic pattern is worn out.

Cleaning of parts:

- All parts – except for the planetary gear carrier – can be degreased in a cleaning bath.
- The planetary gear carrier only needs to be cleaned on the outside with a brush so as not to degrease the planetary gear bearing.

Caution:

The rear wheel hub is not completely waterproof. However, do not use water under pressure (such as pressure washers or water jets) for cleaning to prevent malfunctions due to water penetration.

Lubrication of parts:

Use only SRAM special grease, part no. 0369 135 200 / ... 201.

Lubricate ball retainers and ball tracks only with SRAM Ball Bearing Grease. Part no. 0369.001.015.

- To lubricate the bearing points on the planetary gear sets, position the planetary gear carrier on its crown and apply 2 – 3 drops of oil to the bearing bolts – at the same time turning the planetary gears so that the bearing points are completely wet. Oil axle through the axle bore and axle slot, apply a thin coating of grease to the outside.
- Oil the inside of the sun gears, grease the outside teeth (fill the gaps in the teeth).
- Oil outside teeth and carrier plate on the coupling gear and lightly grease the borehole from right and left.
- Do not apply grease to ring gear but just oil the pawl pockets.
- Slightly grease the actuation ramps of the planetary gear carrier.
- Apply grease all around the seat area of the friction spring. Oil the pawl pockets.
- Spread grease on the complete surfaces inside and outside of the 3 brake segments.
- Regrease ball retainer and insert into lever cone, slightly grease cone surface of the lever cone.
- Line ball bearing running tracks and brake cylinder in hub shell with grease.

TROUBLESHOOTING

Problem	Cause	Remedy
Shifting difficulties	Damaged control cable	Replace control cable
	Incorrect gear setting	Adjust shift system
	To much additional axle attachments between hub and axle nut	Beginning of axle thread must be visible in front of the axle nut
Pedals are carried forward when free-wheeling	Bearings set too tight	Re-adjust bearings
	Loose lock nuts	Tighten lock nuts (15 – 20 Nm)
	Chain is over-tensioned	Reduce chain tension
Hub locks when braking (coaster brake)	Brake segments has run dry	Wash out hub sleeve, repolish and relubricate brake cylinder, renew brake segments
Coaster brake without function	Incorrect mounted friction spring (3, Fig. 1 / Page 88)	Fit friction spring in correct way

SRAM® T3

TECHNICAL DATA / ASSEMBLY REQUIREMENTS

GEAR HUBS

Caution:
Not suitable for tandems, transport bicycles and similar.

Cycle frame:

- Dropouts must be parallel.
- Slot width at rear dropout $10^{+0.5}$ mm.
- The strength must be such that with a maximum braking torque of 250 Nm (2200 in.lbs.) on the rear wheel no residual deformation can occur on the rear structure.

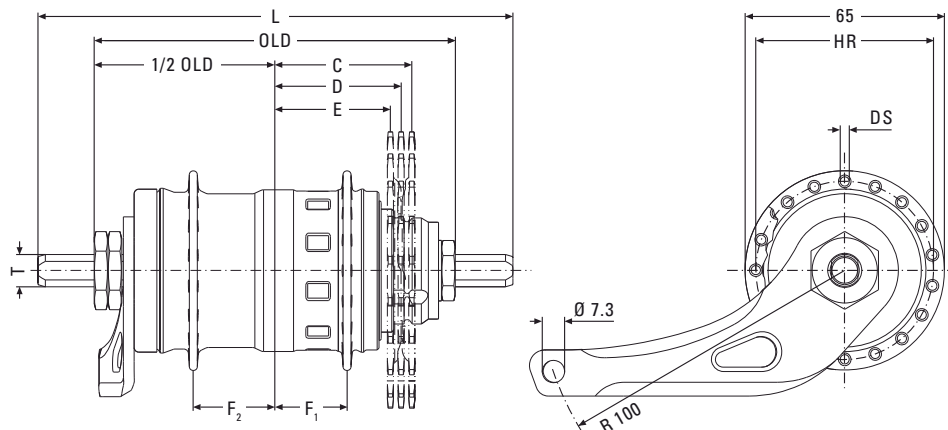

Version with Coaster Brake

GEAR HUBS

		SRAM T3 with coaster brake		SRAM T3 without brake
Type		MH 3115		MH 3105
Brake		Coaster		Without brake
Over Locknut Dim., OLD		118 mm	127 mm	117 mm
	Length, L	155 or 166 mm	166 mm	155 mm or 166 mm
Axle	Ends Diameter, T	FG 10.5		FG 10.5
	Holes	36 or 28	36	36 or 28
Spoke	Hole Diameter, DS	3.0 mm		3.0 mm
	Hole Ref. ø, HR	58 mm		58 mm
	Flange Dist. to 1/2 OLD	F ₁ = 24.5 mm / F ₂ = 25.5 mm		F ₁ = 24.5 mm / F ₂ = 25.5 mm
Gear Hub Ratio	Totally	186 %	Gear steps	←
	Speed 1	0,734	↓	←
	Speed 2	1,000	36 %	←
	Speed 3	1,362	36 %	←
Chain	Line, C/D/E	C = 44.5 mm / D = 41.5 mm / E = 38.5 mm		C = 44 mm / D = 41 mm / E = 38 mm
	Ratio	24", 26", 28" = 2.0 - 2.4 / 20" = 2.0 - 2.5		min. 2.0
Compati- bility	Dimensions	1/2" x 1/8" and 1/2" x 3/32"		1/2" x 1/8" and 1/2" x 3/32"
	Sprocket	16 - 24 Teeth (outward offset - Chain Line C) / 16 - 18 Teeth (straight - Chain Line D) / 16 - 24 Teeth (inward offset - Chain Line E)		
	Shifter	SRAM T3 / SRAM Bandix 3		←
	Tandem	Not suitable for tandems, transport bicycles or similar		
	Weight	1182 g		911 g
Finish	Hub Shell Material	Steel		Steel
	Finish	Matt Chrome Plated		Matt Chrome Plated

SRAM® T3 TECHNICAL DATA / ASSEMBLY REQUIREMENTS

T3

SHIFTERS

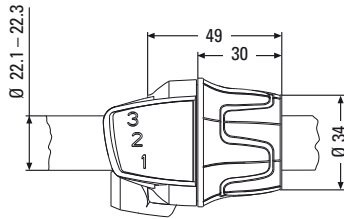

Shifter SRAM T3

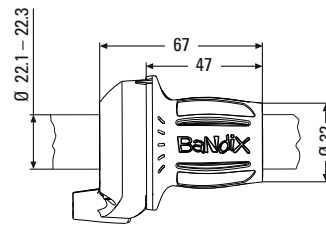
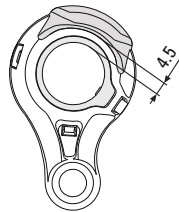

Shifter SRAM T3 BANDIX

SHIFTERS

		SRAM T3 shifter	
Finish	Version	SRAM T3	SRAM T3 BANDIX (for kids)
	Shift cable lengths	2200 mm	2158 mm
	Comp. Cable Housing	Capped, Compressionless with Resin Liner inside	Capped, Compressionless with Resin Liner inside
	Shifter type	SRS twist shifter	SRS twist shifter
	Assembly location	Right side of handlebar	Right side of handlebar
	Compat. gear hub	SRAM T3	SRAM T3
	Gear indicator	Window	Printed
	Barrel adjuster	None	None
	Clamping diameter	22.1 – 22.3 mm	22.1 – 22.3 mm
	Straight handlebar ends	Minim. necessary length for shifter and handlebar grip = 150 mm	Minim. necessary length for shifter and handlebar grip = 155 mm
	Weight	58 g	65 g
	Shift cable	Stainless or galvanized steel	Stainless or galvanized steel
	Housing	Plastic injection molding	PA
Grip cover	Thermoplastic elastomer	Thermoplastic elastomer	
Frame clamp	Aluminum	Aluminum	
Finish	Black	Black	

SRAM® T3 ASSEMBLY

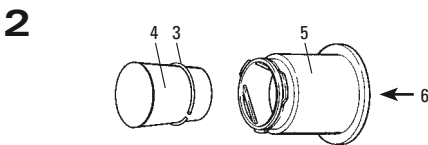
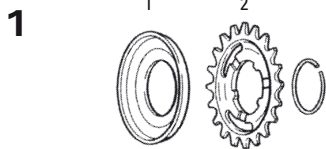

Mounting Tool
Part No. 0582 104 000

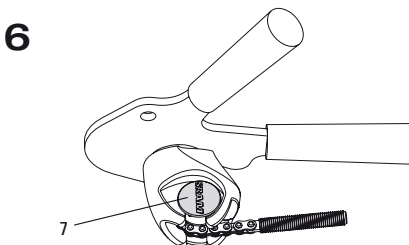
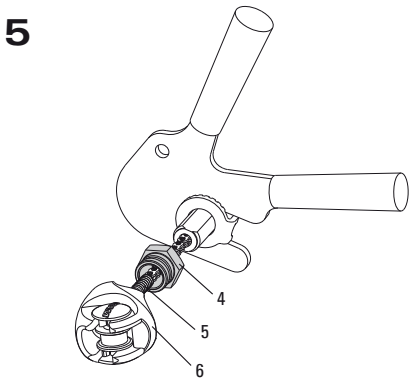
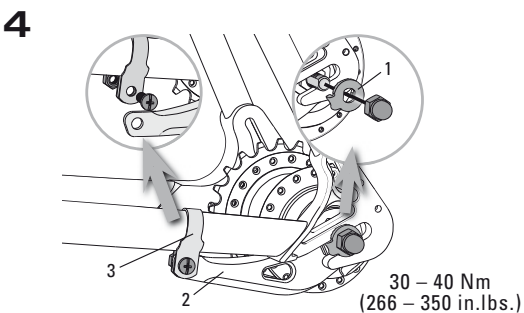
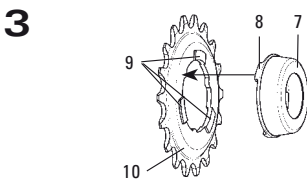

ASSEMBLY HUB

- Lace the wheel as normal. See spoke length table.
- Place the dust cap (1, Fig. 1) and sprocket (2) on the driver.

Advice:
When fitting a straight sprocket (not an offset version), the beadings of the sprocket must lie against the dust cap.
- Push sprocket circlip (3, Fig. 2) onto the cone of tool sleeve (4). Place tool sleeve with large diameter on the driver.
- Push the spring end of sliding sleeve (5) of the tool over the tool sleeve. Thrust sliding sleeve in direction (6), this forces circlip into the recess of the driver.
- Remove tool and check that the circlip is seated correctly.
- Turn dust cap (7, Fig. 3) until the three lugs (8) are between the three beads (9) on the sprocket (10).
- Position dust cap and push towards sprocket until it is felt to lock into place.
- Screw tension chain (5, Fig. 5) into the axle end.
- Placing the wheel in the rear frame.
- Mount the chain.
- Slide one retaining washer (3,5 mm thick) (1, Fig. 4) each axle end. The serrations must bear against the dropout of the frame and the lug must engage in the dropout of the frame.
- Mount the special type axle nut (4, Fig. 5) on the right axle side (drive side) and the axle nut at the other axle end. Tightening torque 30 – 40 Nm (266 – 350 in.lbs.).

- Guide tension chain (5, Fig. 5) through return pulley (6).
- Position return pulley at axle nut (4, Fig. 5) and push until it is felt to lock into place. Turn return pulley until the circular area is at the top (7, Fig. 6).

Caution:

- **Only install additional axle attachments (e.g. struts) between nut and retaining washer.**
- **Cable stop bracket: dimensions see Fig. 9.**
- **Axle end must protrude by min. 1 mm to max. 4 mm beyond the nut (4, Fig. 5).**
- Hub version with coaster brake: Mount the brake lever (3, Fig. 4) between the two straps of the frame clamp (4).

Caution:
Use a suitable frame clamp. The clamp must be seated on the frame without play. Use a self-locking nut! Tightening torque: 2 – 3 Nm (18 – 27 in.lbs.).

Caution:

Check that all the brake system components are functioning properly!

Spoke length table:

Tire Size		Cross		Length	
		28	/ 36 Holes	28	/ 36 Holes
47–406	20" x 1.75 x 2	2 x	/ 3 x	182 mm	/ 184 mm
37–490	22" x 1 3/8	—	/ 3 x	—	/ 228 mm
47–507	24" x 1.75 x 2	2 x	/ 3 x	234 mm	/ 235 mm
37–540	24" x 1 3/8	—	/ 3 x	—	/ 254 mm
47–559	26" x 1.75 x 2	2 x	/ 3 x	258 mm	/ 262 mm
37–590	26" x 1 3/8	—	/ 3 x	—	/ 254 mm
47–622	28" x 1.75	2 x	/ 3 x	289 mm	/ 292 mm
28–622	28" x 1 1/8	—	/ 3 x	—	/ 292 mm
32–622	28" x 1 5/8 x 1 1/4	—	/ 3 x	—	/ 292 mm
37–622	28" x 1 3/8 x 1 5/8	—	/ 3 x	—	/ 292 mm
28–630	27" x 1 1/4 fifty	—	/ 3 x	—	/ 297 mm
32–630	27" x 1 1/4	—	/ 3 x	—	/ 297 mm

Spoke lengths are approximate values. They must be checked through lacing attempts and adjusted accordingly.

7

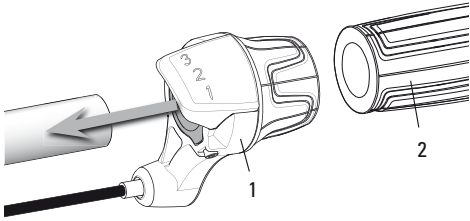

8

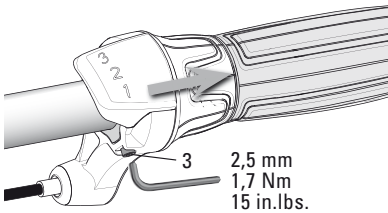

9

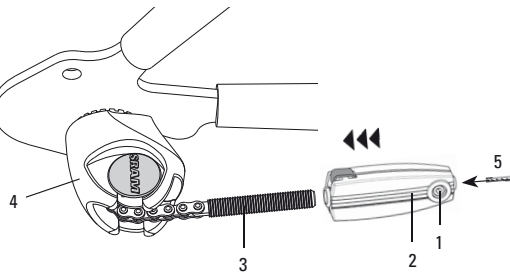

10

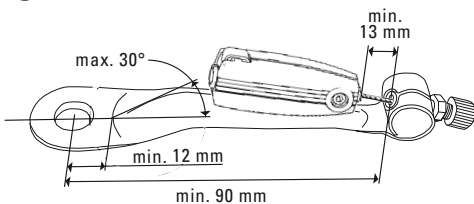

FITTING THE SHIFTER

Caution:
Because of a risk of fracturing, following types of handlebars are not suited:

- thin walled aluminum handlebars, e.g. Hyperlite® handlebars
- carbon handlebars

- Slide the shifter (1, Fig. 7) onto the handlebar.
- Slide the handlebar grip (2, Fig. 7) onto the handlebar.

Caution:
Never use lubricants or solvents when fitting handlebar grips. They have a safety function and must not come free from the handlebar.

- Place the shifter on the handlebar grip (Fig. 7) and position so that you can use it comfortably. Tighten the clamping bolt (3). 2.5 mm Allen wrench, torque 2 Nm (15 in.lbs.).

- Caution:**
- Check that shifter and brake lever can be easily operated (if necessary, realign).
 - Never ride without handlebar grips. The turning grip of the twist shifter could become loose. This can result in severe injuries.

Caution:
Before setting out on any ride, always check the correct and trouble-free operation of the shift system and brakes.

FITTING THE SHIFT CABLE

- Advice:**
- Make sure that the cable housing length is sufficient to permit turning of the handlebar over its full range.
 - Also consider the influence of adjustable handlebars and stems on the cable housing length.

- Fasten the cable housing on the frame.

Advice:

 - In case of continuous cable housing the cable housing must be secured in equidistant intervals on the frame and must be free to move at the securing points.
 - When fitting the cable avoid small radius.
 - Use only compressionless cable housings with resin liner inside and capped.

Advice:
To avoid malfunction the cable frictional force must not exceed 6 N (1.4 lbs.).

- Feed the shifter cable into the locating sleeve (5, Fig. 9), fix at the appropriate length (cable stop bracket: see Fig. 10) using the clamping bolt (1). Allen key 2.5 mm, tightening torque 1.5 Nm (13 in.lbs.). Shorten any cable which is sticking out.

- Connect to the hub: push locating sleeve (2, Fig. 9) loosely onto small pull rod (3).

Adjustment

- Place the shifter in gear position "3". Move the crank to check that the gear is engaged.
- To make the adjustment, the cable must be taut in third gear to be able to transfer a shift movement directly to the hub.
- Push locating sleeve (2, Fig. 9) onto the small pull rod (3) until the control cable is taut. Make sure that you don't pull the indicator chain out of the return pulley (4).

Check:

- Place shifter in gear position "1" while moving the crank.
- Setting too loose: In gear position "1" the tension chain can be pulled out of the return pulley by hand.
- Setting too tight: It is difficult to place the shift lever in gear position "1".
- If required, readjust the shift mechanism (in third gear).

Caution:
Before setting out on any ride, always check the correct and trouble-free operation of the shift system and brakes

SRAM® T3 MAINTENANCE

1 Coaster brake / MH 3115

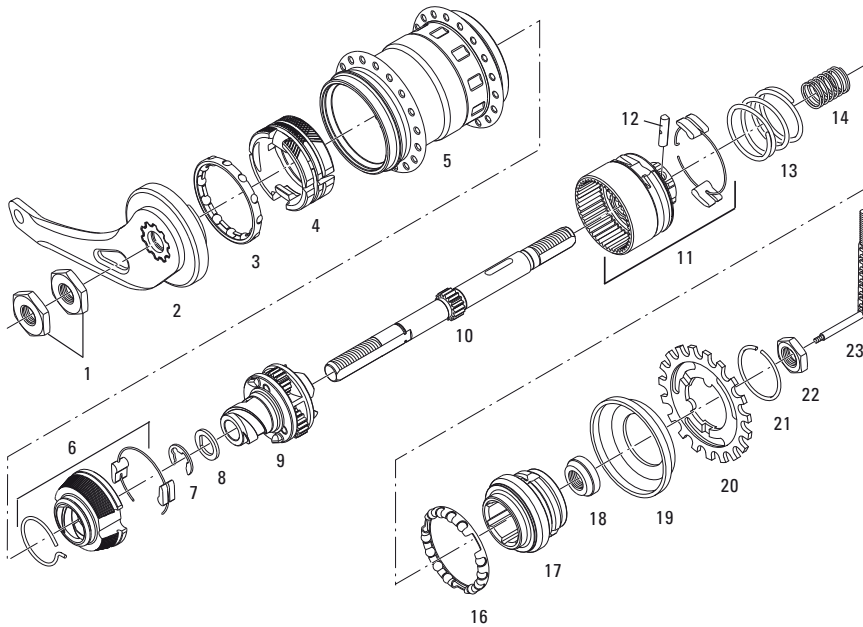

2 Without brake / MH 3105

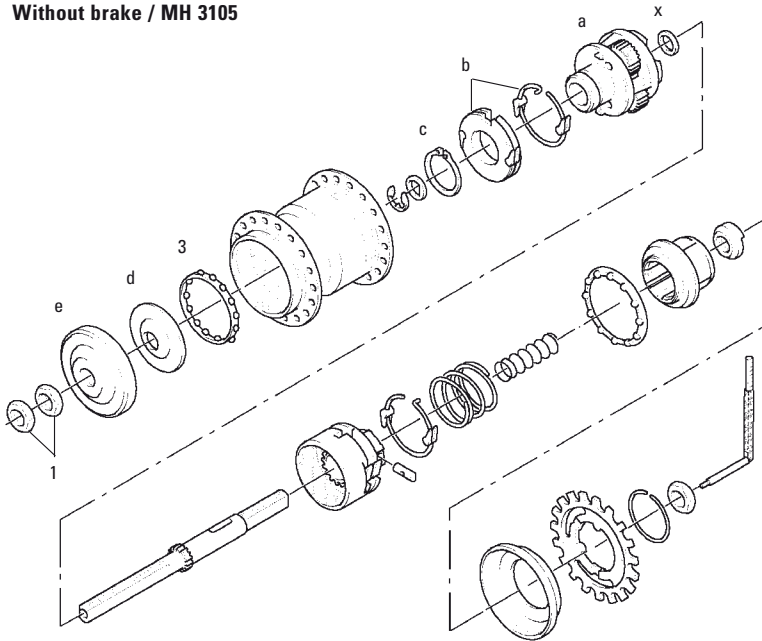

SERVICE

To maintain optimal performance and durability of your components, periodic maintenance is required. We recommend that you have your components serviced every 2 year or 5000 km by a qualified bicycle mechanic.

REMOVE WHEEL

- Apply fingertip pressure onto the metal key of locating sleeve to release it from the pull rod.
- Remove return pulley.
- Screw off both axle nuts and remove retaining washers.
- Remove wheel.

DISMANTLING HUB

see Fig. 1

- Unscrew indicator chain (23), remove circlip (21), sprocket (20), dust cap (19) and clamp axle (10) on the driver side.
- Unlock hexagonal nuts (1) and unscrew.
- Remove brake arm (2), ball retainer (3) and brake sleeve (4) and remove hub shell (5).
- Remove safety washer (7), thrust washer (8) and then the planet carrier (9) complete with brake cone (6). Unscrew the brake cone from the planet carrier.
- Clamp other axle end.
- Loosen the lock nut (22) and fixed cone (18) and remove.
- Remove driver (17), compression springs (14 and 13) and ball retainer (16).
- Push the sliding key (12) through the large bore in the coupling wheel of the ring gear (11) – the bore and thrust block must be aligned.
- Remove the gear ring (11) from the axle.

Advice:

The dismantly and reassembly of the hubs without brake should be carried out in the same way (Fig. 2).

Differences

- There is no brake sleeve (4) and brake cone (6).
- The planet carriers (a) have a cylindrical shaft instead of a flat thread, which houses a pawl carrier (b) held by a safety washer instead of the brake cone.
- Further differences: instead of a lever cone (2) for type MH 3115, an adjusting cone (d) with dust cap (e) for type MH 3105 are fitted.

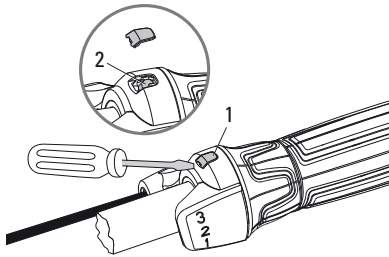
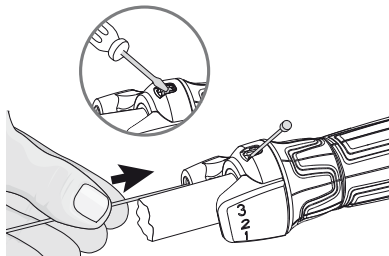
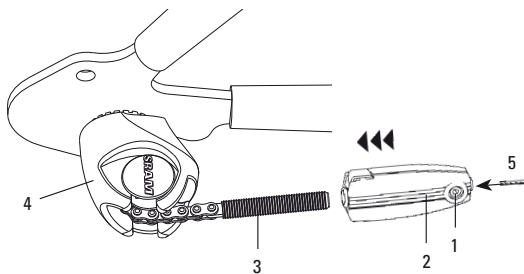
3

4

5

REASSEMBLY HUB

see Fig. 1 / 2

Lubrication see "MAINTENANCE / LUBRICATION".

- Clamp the hub axle (10) with the slot for thrust block upwards), fit ring gear (11) and align the large bore in the coupling wheel with the slot. Position the radius of the sliding key (12) facing downwards and turn the coupling wheel slightly.
- Fit the compression springs (13 and 14).
- Place ball retainer with balls in (16) on ring gear (11), mount driver (17), fit fixed cone and lock with hexagonal nut (22), tightening torque 15 – 20 Nm (133 – 177 in.lbs).
- Turn hub over and slide on planet carrier (9) – thrust washer (X) must first be fitted for types MH 3105. (For type MH 3115, this washer is already integrated in the planet carrier). Mount thrust washer (8) and place safety washer (7) in the recess of the axle.
- Screw brake cone (6, type MH 3115) onto the flat thread – for types MH 3105 mount pawl carrier (b) and secure in place using safety washer (c).
- Fit hub shell (5) – turning it counter-clockwise slightly to get past the stop notches – until the shell runs cleanly onto the ball retainer.
- For type MH 3115, insert the brake sleeve (4) so that the spring end of the friction spring on the brake sleeve (6) sits in one of the two slots on the brake sleeve. Insert the ball retainer and fit the lever cone – move the lever cone lightly until the lugs on the brake lever catch in the grooves on the adjusting cone.
- Adjust the hub clearance by screwing on hexagonal nut (1) until the hub shell runs free of play but not under tension. Lock with a second nut to a tightening torque of 15 – 20 Nm (133 – 177 in.lbs.).
- For type MH 3105 insert ball retainer (3), mount adjusting cone (d) with dust cap (e) and hexagonal nuts (1). Adjust the hub clearance as for type MH 3115.
- For type MH 3125, the ball retainer (f) and dust cap (pressed in) normally remain in the hub shell. The hub clearance is set with adjusting cone (D) as for type MH 3115.

Caution:

Check that all the brake system components are functioning properly!

CHANGING THE SHIFT CABLE

Advice:

Always use new, high-quality cables and compressionless cable housings with end caps.

- Turn the twist shifter to 3rd gear.
- Detach the cable from the locating sleeve.
- Remove the cable housing. Cut the cable off 15 cm (6") from the shifter barrel adjuster. Discard the old cable and cable housing.
- Remove the cap (1, Fig. 3) from the shifter. The nipple (2) of the inner cable is now visible.
- Push or pull the old inner cable out of the shifter (Fig. 4), e.g. using a small screwdriver.
- Guide the new inner cable into the cable inlet, through the shifter and the new cable housing.
- Insert the cap in the shifter.
- Feed the shifter cable into the locating sleeve (5, Fig. 5), fix at the appropriate length using the clamping bolt (1). Allan key 2.5 mm, tightening torque 1.5 Nm (13 in.lbs.). Shorten any cable which is sticking out.
- Connect to the hub: push locating sleeve (2, Fig. 5) loosely onto small pull rod (3).

ADJUSTMENT

- Place the shifter in gear position "3". Move the crank to check that the gear is engaged.
- To make the adjustment, the cable must be taut in third gear to be able to transfer a shift movement directly to the hub.
- Push locating sleeve (2, Fig. 5) onto the small pull rod (3) until the control cable is taut. Make sure that you don't pull the indicator chain out of the return pulley (4).

Check:

- Place shifter in gear position "1" while moving the crank.
- Setting too loose: In gear position "1" the tension chain can be pulled out of the return pulley by hand.
- Setting too tight: It is difficult to place the shift lever in gear position "1".
- If required, readjust the shift mechanism (in third gear).

6

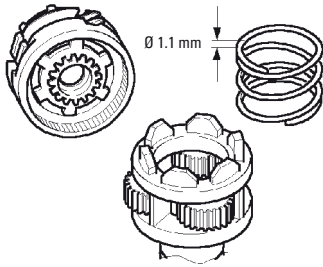

TECHNICAL CHANGES

Coaster Brake:

Improved braking in third gear after production date CW 38/96

- In case of repair, older hub models (Fig. 6) can be converted with a repair set (Fig. 7). It is important that all three parts are replaced at the same time – new, reinforced compression springs, planet carrier with 4 lugs and ring gear with 4 lugs on the driving plate.
- Feature of the new or converted hubs: When braking in third gear, the indicator chain moves out of the return pulley by approx. one chain link – after braking, the tension chain returns immediately to its normal position.

7

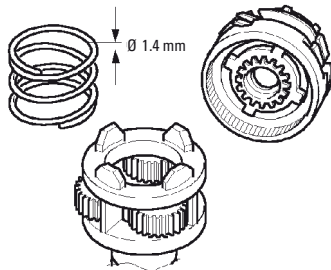

MAINTENANCE / LUBRICATION

Caution:

The rear wheel hub is provided with permanent lubrication and is almost maintenance-free under normal conditions. If the coaster brake is loaded excessively its effect can be too strong, the hub may lock. In such a case the 3 brake segments must be lubricated only with SRAM special grease (Part No. 0369 135 200/ ...201).

The brake shell must be renewed, if, as a result of wear, the grooves on the outer surface are scarcely visible.

Cleaning of parts:

- All parts – except for the planetary gear carrier – can be degreased in a cleaning bath.
- The planetary gear carrier only needs to be cleaned on the outside with a brush so as not to degrease the planetary gear bearing.

Lubrication of parts:

Use only SRAM special grease, part no. 0369 135 200 / ... 201.

Lubricate ball retainers and ball tracks only with SRAM Ball Bearing Grease. Part no. 0369.001.015.

- To lubricate the bearing points on the planetary gear sets, position the planetary gear carrier on its crown and apply 2 – 3 drops of oil to the bearing bolts – at the same time turning the planetary gears so that the bearing points are completely wet. Oil axle through the axle bore and axle slot, apply a thin coating of grease to the outside.
- Oil the inside of the sun gears, grease the outside teeth (fill the gaps in the teeth).
- Oil outside teeth and carrier plate on the coupling gear and lightly grease the borehole from right and left.
- Do not apply grease to ring gear but just oil the pawl pockets.
- Grease the brake cone in the borehole and the friction spring.
- Spread grease on the inside and outside of the brake shell.
- Fill lever cone with grease reserves for brakes.
- Regrease ball retainer, line ball bearing running tracks with grease.

Caution:

The rear wheel hub is not completely waterproof. However, do not use water under pressure (such as pressure washers or water jets) for cleaning to prevent malfunctions due to water penetration.

TROUBLESHOOTING

Problem	Cause	Remedy
Shifting difficulties	Incorrect gear setting	Adjust shifting system, oil control cable, check that cable stop is fastened correctly.
Pedals are carried forward when freewheeling	Bearings set too tight	Re-adjust bearing
	Loose lock nuts	Tighten lock nuts (15 – 20 Nm)
	Chain is overtensioned	Reduce chain tension
Ccoaster brake: Hub locks when braking	Brake shell has run dry	Wash out hub sleeve, repolish and relubricate brake cylinder, renew brake shell
Pedals yield slowly during braking (does not impair safety).	Brake cone / brake sleeve	Replace brake cone and brake sleeve

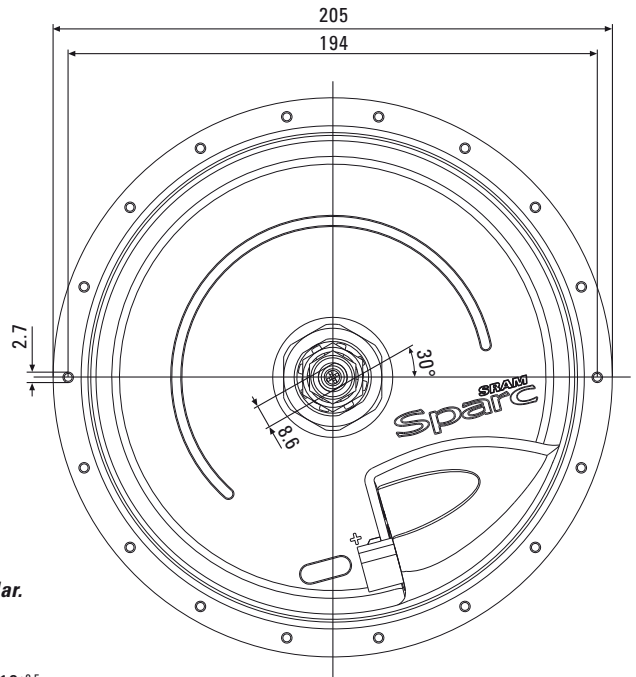
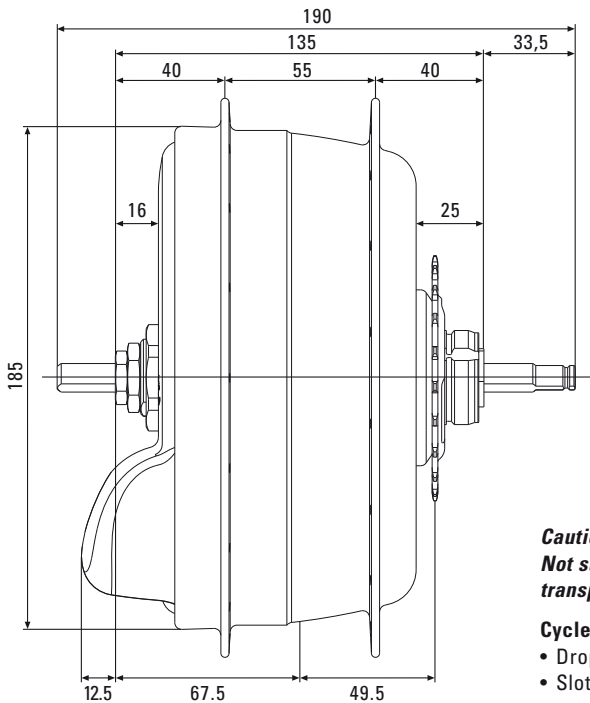

Caution:
 Not suitable for tandems,
 transport bicycles and similar.

- Cycle frame:**
- Dropouts must be parallel.
 - Slot width at rear dropout 10^{+0.5} mm.

GEAR HUBS

		Sparc hub 16,8 V		
Electric Drive	Wheel ø	28" / 26"	20"	26" USA
	Econ Mode	22 km/h	16 km/h	26 km/h
	Speed Mode	25 km/h	23 km/h	32 km/h
	Econ Mode	ca. 35 km*		
	Speed Mode	ca. 25 km*		
	Engine Type	2 x 16,8 V DC engines		
	Power	2 x 100 W max.		
	Assist Type	Pedal controlled		
	Assist Ratio	Econ / Speed		
	Brake	None		
Axle	Over Locknut Dim.	135 mm		
	Length	190 mm		
	Ends Diameter	FG 10.5		
	Holes	36		
	Hole Diameter	2.9 mm		
	Hole Reference ø	194 mm		
	Totally	251 %		
	Speed 1/2/3/4/5	63 % / 78 % / 100 % / 128 % / 158 %		
	Usable Dimension	1/2" x 1/8" or 1/2" x 3/32"		
	Line	49.5 mm (only off-set sprockets)		
Chain	Ratio	1.7 – 2.6		
	Shifter Compatib.	Sparc Shifter		
	Frame Compatib.	Dropouts max. 7 mm		
		Over Locknut Dim. (OLD) 135 mm		
	Tandem	Not suitable for tandems, transport bicycles or similar		
	Weight	2450 g		

SHIFTER

		Sparc Shifter (Drawing see Page 66)				
Shifter Type	Twist Shifter					
Cable Length	1450 mm	1550 mm	1650 mm	1750 mm	1850 mm	
	1950 mm	2150 mm	2350 mm			
Gear Indication	Window					
Clamping Diameter	22.1 – 22.3 mm					
Straight handlebar ends	Min. necessary length for shifter a. handlebar grip = 150 mm					
Length of shifter	76 mm					
Weight	N/A					

REMOTE CONTROL

		Sparc Remote Control Unit					
Cable Length (mm)	1500	1600	1700	1800	2000	2200	
Mode Selector	Off / Econ / Speed						
Mode Indication	Printed						
Clamping Diameter	22.1 – 22.3 mm						
Cable Connection	3.5 mm stereo jack						
Weight	45 g						

BATTERY BOX

		Sparc Battery Box 16,8 V				
Cable Length (mm)	650	750	850	1400	1650	1950
Battery	16,8 V / 8 Ah NiMH battery					
Charger	16,8 V / 2 A					
Charging time	4 hours 30 minutes					
Luggage carrier comp.	Struts: ø 8 mm / dist. 68 mm center to center / parallel					
Weight	2400 g					

* Average speed 20 km/h in the plain using a 28-inch wheel and assuming 75-watt input by the rider. (US version: SPEED = 15 miles, ECON = 21 miles)
 The range achieved by a single battery charge depends on various factors. These include drive mode, the condition of the battery, the road conditions and particularly the cyclist's own effort.

SPARC® ASSEMBLY

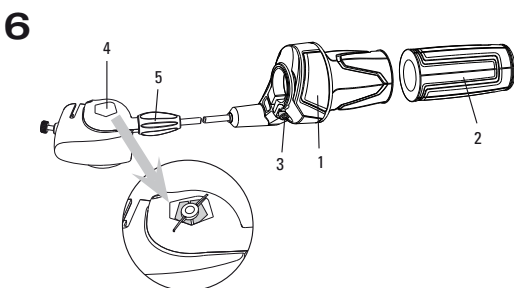
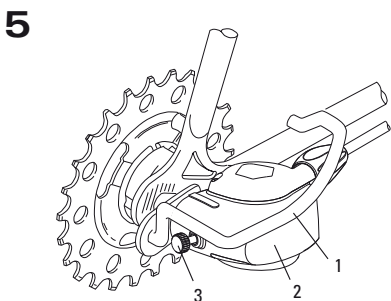
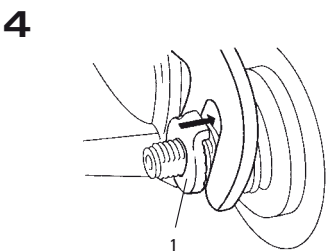
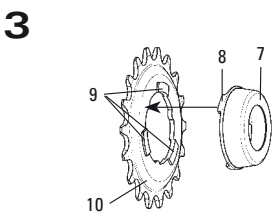
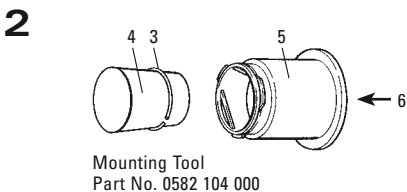
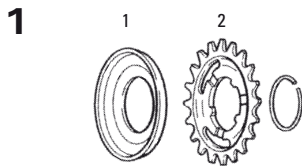

LACING THE WHEEL

Version 28" / 26":

1-cross only.

All spoke heads must be positioned either at the outside or the inside of the respective spoke flange.

Spoke tension about 1000 N recommended.

Version 20":

• 1-cross:

Use only rim „Rigida 20x406 59 (L 01 12 E)“ (or contact SRAM).

All spoke heads must be positioned at the outside of the spoke flange.

Spoke tension about 1000 N recommended.

• Radial lacing:

No restrictions.

Spoke tension about 1000 N recommended.

• **Note also, that different stem lengths and handlebar positions effects cable housing length.**

• Slide the shifter (1, **Fig. 6**) onto the handlebar.

• Slide the handlebar grip (2) onto the handlebar.

Caution:

Never use lubricants or solvents when fitting handlebar grips. They have a safety function and must not come free from the handlebar.

• Place the shifter on the handlebar grip and position so that you can use it comfortably. Tighten the clamping bolt (3). 3 mm Allen key, torque 3.5 – 4 Nm (31 – 35 in.lbs.).

Caution:

• **Check that shifter and brake lever can be easily operated (if necessary, realign).**

• **Never ride without handlebar grips. The turning grip of the twist shifter could become loose. This can result in severe injuries.**

• When fitting the cable (1, **Fig. 7**) avoid small radius.

• Last attachment point is on the lower rear wheel fork (2, **Fig. 7**) immediately behind the chain wheel.

Cable housing must be movable inside attachment.

ASSEMBLY HUB

• Place the dust cap (1, **Fig. 1**) and sprocket (2) on the driver. Toothing close to the hub (only sprocket version off-set).

• Push sprocket circlip (3, **Fig. 2**) onto the cone of tool sleeve (4). Place tool sleeve with large diameter on the driver.

• Push the spring end of sliding sleeve (5) off-the tool over the tool sleeve. Thrust sliding sleeve in direction (6), this forces circlip into the recess of the driver.

• Remove tool and check that the circlip is seated correctly.

• Turn dust cap (7, **Fig. 3**) until the three lugs (8) are between the three beads (9) on the sprocket (10).

• Position dust cap and push towards sprocket until it is felt to lock into place.

• Placing the wheel in the rear frame.

Advice:

Dropouts must be parallel.

• Fit new retaining washer (3,5 mm thick) on left axle ends (1, **Fig. 4**). The serrations must bear against the dropout and the lug must engage in the dropout slot.

• On the sprocket side fit the protective bracket (1, **Fig. 5**) directly below the axle nut. Tightening torque on axle nuts 30 – 40 Nm (266 – 350 in.lbs.).

Advice:

• **If a different protective bracket is used the thickness of the attachment plate must be max. 3 mm.**

• **Do not use additional washers.**

• **At least the beginning of the axle thread must be visible in front of the axle nut.**

INSTALLING CLICK BOX

• Insert shift rod (1, **Fig. 8**) in shift tube (2) (oil parts lightly) and then push into axle bore as far as the stop. Turn slot (6) in shift tube to a position where it is easily visible.

• Push locating sleeve (3) with guiding rib (4) to the front onto the hub axle – making sure that the internal lug (5) is guided in the slot (6) of the shift tube until it can be felt – and heard – to engage.

• Turn locating sleeve on the axle (7) until the guiding rib (4) is facing roughly upwards.

• Place shifter in gear position “2”.

• Push on clickbox (2, **Fig. 5**) to the stop on the axle. The guiding rib (4, **Fig. 8**) of the locating sleeve thereby engages in the slot on the housing. In the end position tighten up the knurled bolt (3, **Fig. 5**) by hand (0.3 Nm / 2.7 in.lbs.).

ADJUSTMENT HUB

• Be sure to reset rotational shifter from 4th. to 3rd gear.

• Match up the arrow marks in the Clickbox viewing window (4, **Fig. 6**) by turning the barrel adjuster (5).

ASSEMBLY SHIFTER

Advice:

• **When choosing cable housing lengths, be sure to allow enough housing for an extreme turn of the handlebars in both directions.**



7

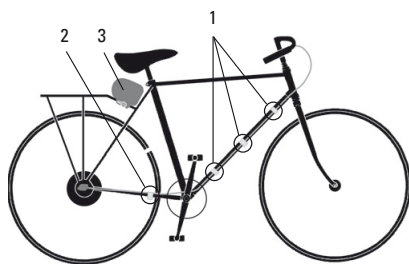

8

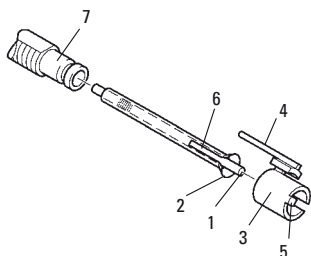

9

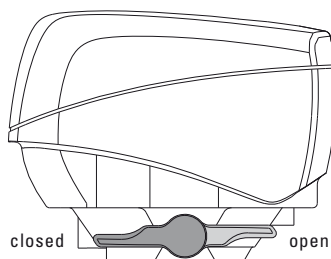

10

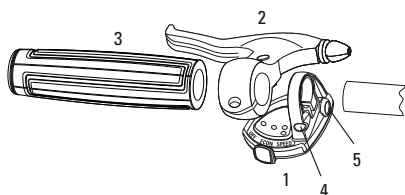

ASSEMBLY BATTERY BOX

- Pull both quick releases outward and turn them to the „open“ position (Fig. 9).
- Position battery box onto luggage carrier struts (3, Fig. 7).
- Push quick releases inwards and turn them to the „closed“ position (Fig. 9).
- Slide plug of battery cable in the slot of the battery box until it snaps in.
- Attach cable along the frame or luggage carrier strut.

Advice:

Last attachment point of the cable at the rear fork: approx. 8 cm away from the axle end.

Do not jam the cable between frame and rear hub and keep it away from the rotating hub shell.

- Slide plug in the slot on the hub until it snaps in.

Advice:

Closed elements such as brazed-on eye bolts are not suitable because plug will not pass through.

STORING BATTERY BOX

The battery box should be stored fully charged in a dry and cool place. Remove the plug of the battery cable from the box.

All batteries are shipped with an additional documentation about the last charging date within our SRAM facility. This documentation of battery charging also allows you to fill in the dates of additional charge actions that you would need to perform if the batteries stay in your warehouse over a longer period of time. You can identify the next necessary charge date at a glance (at least 3 months after last charge).

ASSEMBLY REMOTE CONTROL UNIT

- Slide remote control unit (1, Fig. 10) onto handlebar.
- Mount brake lever (2) and fixed grip (3).
- Adjust remote control unit on handlebar and tighten the bolt (4) with a torque of 1.5 Nm (13 in.lbs.).
- Slide plug of remote control cable in the slot (5) of the remote control unit until it snaps in.
- Attach cable along the frame.

Advice:

Last attachment point of the cable at the rear fork: approx. 8 cm away from the axle end.

Do not jam the cable between frame and rear hub.

Make a cable loop between plug and cable attachment point to avoid tensile load.

- Slide the plug straightly in the slot on the hub until it snaps in. Angular installation may damage the slot.

Check:

Switch remote control to „Speed“ position and rotate the rear wheel (Battery has to be fully charged). At least 1 green and the red LED must gleam. If not, assemble plugs again completely / right.

SPARC® MAINTENANCE

1

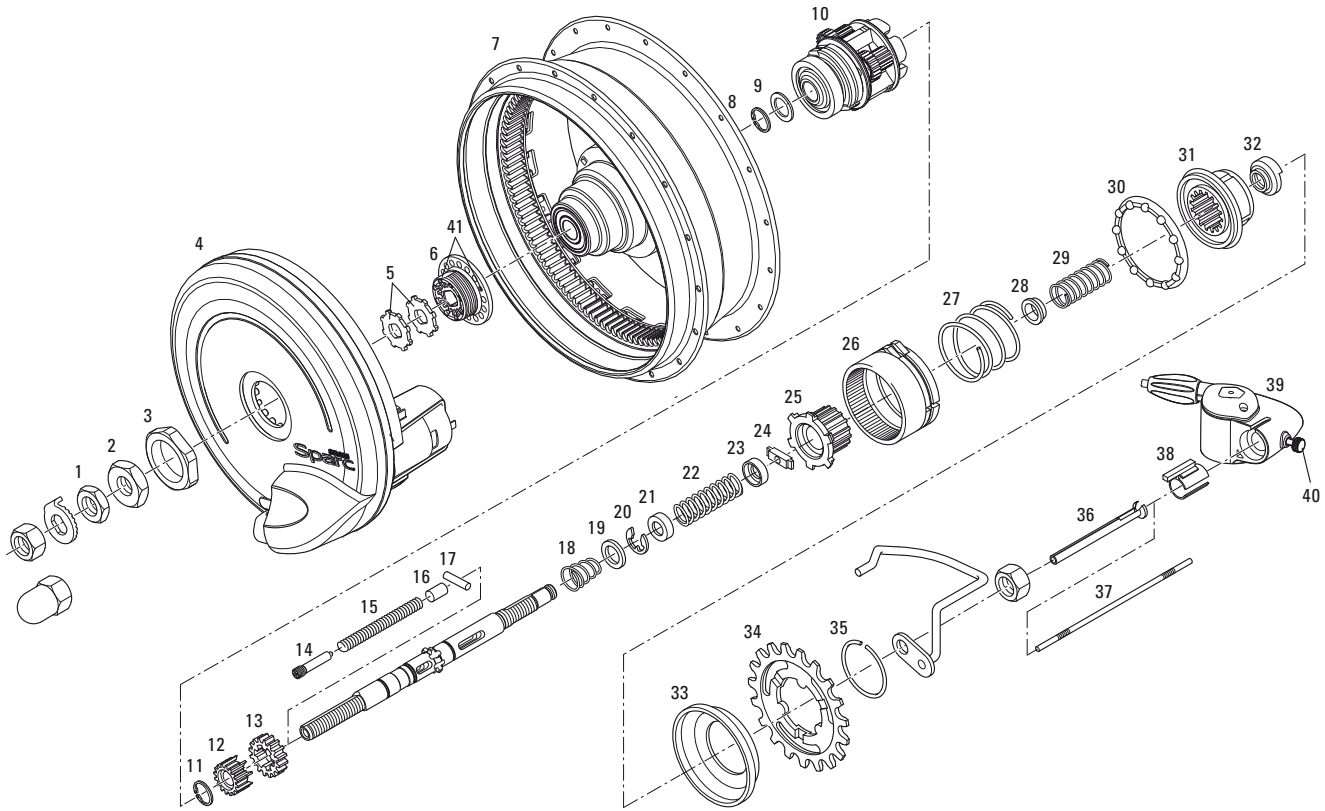

2

Sparc mounting aid
Part No. 65 3024 001 000

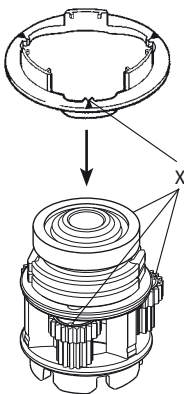

REMOVE WHEEL

- Pull the remote control cable plug off the hub.
- Apply fingertip pressure onto the tap and pull battery cable plug off the hub.
- Loosen the knurled screw (40, **Fig. 1**) and pull the Clickbox off the axle.
- Disengage the red locating sleeve (38) and pull it off. Remove shift rod (37) and shift tube (36) out of the axle bore.
- Remove wheel.

ELECTRIC DRIVE

Remove:

- Unscrew resin nut (3, **Fig. 1**).
- Remove electric drive (4).

Caution:

Do not disassemble and do not lubricate the electric drive.

Reassembly:

- Position electric drive onto hub.
- While rotating the electric drive push it inside until the two small inside pins engage in corresponding small holes (41). Check: The thread (6) must be visible at least 8 mm.
- Screw on resin nut (3) with a torque of 3 – 5 Nm (27 – 44 in.lbs.).

DISMANTLING GEAR HUB

see Fig. 1

- Remove circlip (35), sprocket (34) and dust cap (33).
- Clamp hub with the two axle flats sprocket side facing downwards.
- Remove electric drive (4) (see left column).
- Unscrew the locknuts (1+2).
- Remove plate (6) and 2 washers (5).
- Remove hub shell (7).
- Remove circlip (8) and washer (9).
- Remove planetary gear carrier (10) and circlip (11).
- Clamp other axle end.
- Unscrew fixed cone (32).
- Remove driver (31), compression spring (29), large compression spring (27) and ball retainer (30). – Withdraw gear ring (26) and coupling gear (25) and remove cover (28) from the coupling gear.
- Take out thrust block (24), (to do this compress the spring). Remove spring (22) and the two covers (23/21).
- Dismantle retaining washer (20), washer (19), conical compression spring (18), and-the large sun gear (13).
- Clamp other axle end.
- Unscrew grey grub screw (14) – dismantle spring (15), guide bolt (16) and thrust block (17).
- Remove small sun gear (12).



3

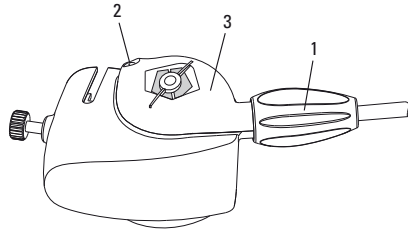

4

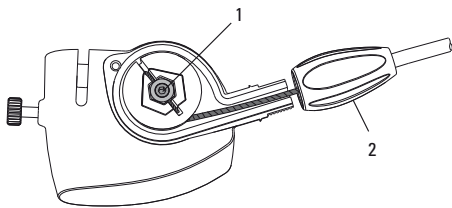

5

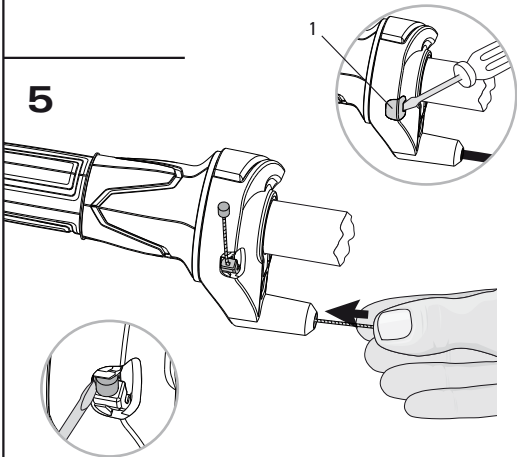

6

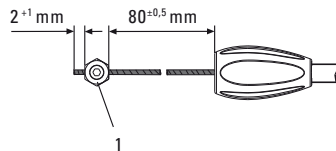

7

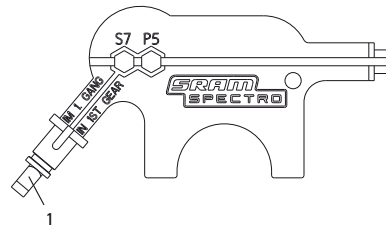

REASSEMBLY HUB

see Fig. 1

Lubrication see "LUBRICATION GEAR HUB", next page.

- Clamp axle with small internal thread upwards.
 - Position small sun gear (12) with crown gears to the front.
 - Position thrust block (17) in the slotted hole (is laterally guided when the sun gear-is mounted).
 - Locate bolt (16), then spring (15) in the axle-and screw in grey grub screw (14) until it-is-flush with the axle end.
 - Clamp other axle end. Fit large sun gear (13). Position conical compression spring (18), with the large diameter first. Compress spring and fit washer (19) and retaining washer (20).
 - Assemble cover (21), compression spring with 7 turns (22) and the second cover (23, insides to the spring).
 - Compress spring and position thrust block (24) (it is the same both sides) in the center of the slotted hole.
 - Position coupling gear (25) with carrier plate facing downwards.
 - Fit cover (28, inside to the spring) for compression spring.
 - Position gear ring (26) over the teeth of the-coupling gear.
 - Place ball retainer (30), with balls below on-the gear ring.
 - Position large compression spring (27) on-gear ring.
 - Mount compression spring with 13 turns (29) on the axle. (Is supported in the coupling wheel by the cover.)
 - Locate driver (31), press it down and screw on fixed cone (32). Tightening torque 20 Nm.
 - Clamp other axle end.
 - Push on thrust washer (11) and fit planetary gear carrier (10). In doing this: Position mounting aid (Fig. 2) on the planetary gear carrier so that the (X) markings on the three planetary gears match with the mounting aid.
 - Insert planetary gear carrier, place thrust-washer (9) and mount circlip (8) in recess.
- Remove the mounting aid.

Advice:

If the gears are not accurately installed the-hub may be tight to move. This could lead to-damage to the gear-wheels in operation.

- Mount hub shell (7), with a slight counterclockwise turn.
- Fit plate (6) and 2 washers (5).
- Screw on counternuts (2+1), tightening torque 15 – 20 Nm (133 – 177 in.lbs.).
- Reassemble electric drive.

CHANGING THE SHIFT CABLE

Advice:

Always use new, high-quality cables and compressionless cable housings with end caps.

- Turn the twist shifter to 1st gear.

Advice:

Do not remove the Clickbox from the axle end.

- Unscrew the barrel adjuster (1, Fig. 3) completely. Unscrew the cover screw (2), brush aside the barrel adjuster (1) and remove the cover (3).
 - Withdraw the shifter cable and clamping bolt (1, Fig. 4) upwards, loosen the clamp screw with a 2.5 mm Allen key and pull the clamping piece from the cable.
 - Remove and discard the old cable housing.
 - Remove the cap (1, Fig. 5) from the shifter.
 - Push or pull the old inner cable (Fig. 5) out of the shifter, e.g. using a small screwdriver.
 - Guide the new inner cable into the cable inlet, through the shifter and the new cable housing.
 - Insert the cap in the shifter.
 - Position clamping bolt (1, Fig. 6) at a distance of 80 mm.
- Advice:**
- For positioning the clamping bolt use adjust gauge (Fig. 7) (Part. No. 65 0324 107 000). Tighten the clamping screw with a 2.5 mm Allen key. Tightening torque 1.5 Nm (13 in.lbs.). Cut off the cable end to 2 – 3 mm.
 - Locate clamping bolt (1, Fig. 4) and place shifter cable around the carrier cylinder (counter-clockwise winding).
 - Position the cover (3, Fig. 3) and tighten up with the cover screw (2). Torque 0.35 – 0.45 Nm (3.1 – 4.0 in.lbs.). Screw in the barrel adjuster (1) completely.

Advice:

- If you want to remove the Clickbox from the axle end for changing the cable, do as follows:
 - Place shifter in gear position "1".
 - Loosen the knurled screw and pull the Clickbox off the axle.
 - Now it's essential to push the end (1, Fig. 7) of the adjust gauge completely into the Clickbox and tighten up the knurled bolt (so that you maintain the initial tension of the spring inside the Clickbox).
 - Change cable as per description above.
- If you remove the Clickbox from the axle and change the cable without using the end of the adjust gauge, then you will lose the initial tension of the spring inside the Clickbox. In this case you must assemble the cable by placing it around the carrier cylinder with an additional winding (Fig. 4).

ADJUSTMENT

- Be sure to reset rotational shifter from 4th to 3rd gear.
- Match up the marks in the Clickbox viewing window (Fig. 3) by turning the adjusting screw (1).

SPARC® MAINTENANCE

8 16.8 V NiMH-battery

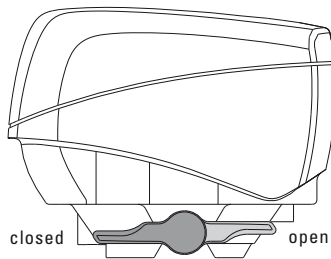

9 16.8 V NiMH-battery

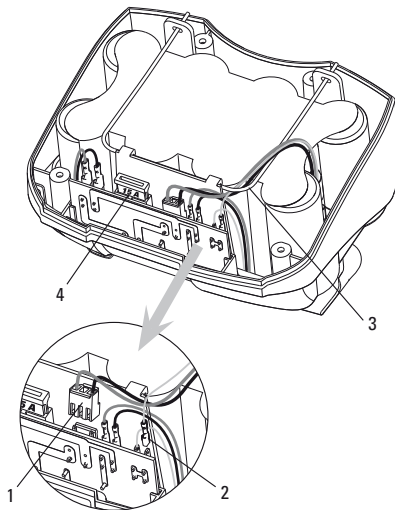

10 12 V lead battery

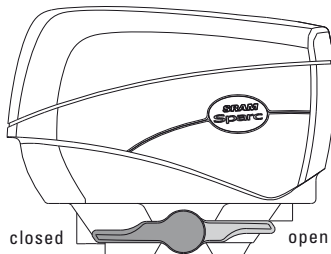

11 12 V lead battery

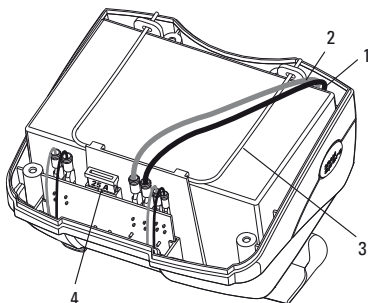

LUBRICATION GEAR HUB

Cleaning of parts:

- All parts – except for the planetary gear carrier – can be degreased in a cleaning bath.
- The planetary gear carrier only needs to be cleaned on the outside with a brush so as not to degrease the planetary gear bearing.

Lubrication of parts:

Use only SRAM special grease, part no. 0369 135 200 / ... 201.

Lubricate ball retainers and ball tracks only with SRAM Ball Bearing Grease. Part no. 0369.001.015.

- To lubricate the bearing points on the planetary gear sets, position the planetary gear carrier on its crown and apply 2 – 3 drops of oil to the bearing bolts – at the same time turning the planetary gears so that the bearing points are completely wet.
- Oil axle through the axle bore and axle slot, apply a thin coating of grease to the outside.
- Oil the inside of the sun gears, grease the outside teeth (fill the gaps in the teeth).
- Oil outside teeth and carrier plate on the bore-coupling gear and lightly grease the borehole from right and left.
- Do not apply grease to ring gear but just oil the pawl pockets.
- Regrease ball retainer, line ball bearing running tracks with grease.

Advice:

The rear wheel hub is not completely waterproof. However, do not use water under pressure (such as pressure washers or water jets) for cleaning to prevent malfunctions due to water penetration.

BATTERY CHANGE

16,8 V NiMH battery

(see Fig. 8 and 9)

Disassembly:

- Apply fingertip pressure onto the tap and pull battery cable plug off the battery box.
- Turn quick releases to the „open“ position (Fig. 8) and pull them outward.
- Take off battery box from luggage carrier.
- Unscrew the 4 bottom screws (slotted screwdriver / Torx T10) and take off battery box cover.
- Hang out stirrup (3, Fig. 9).
- Take out battery and pull off plug (1) and cable shoe (2) from card modul.

Reassembly:

- Connect plug and cable shoe of new battery to card modul:
 - white plug with red and black cable (1, Fig. 9)
 - cable shoe with yellow cable (2) and put battery inside.
- Assemble stirrup (3) (bulge downward). Pay attention of correct cable routing (Fig. 9).
- Mount battery box cover by the 4 screws.
- Pull both Quick Releases outward and turn them to the „open“ position (Fig. 8).
- Position battery box onto luggage carrier struts.
- Push Quick Releases inwards and turn them to the „closed“ position (Fig. 8).
- Slide plug of battery cable in the slot of the battery box until it snaps in.

Advice:

Use only batteries as specified by SRAM.

12 V lead battery

(see Fig. 10 and 11)

Disassembly:

- Apply fingertip pressure onto the tap and pull battery cable plug off the battery box.
- Turn quick releases to the „open“ position (Fig. 10) and pull them outward.
- Take off battery box from luggage carrier.
- Unscrew the 4 bottom screws (slotted screwdriver / Torx T10) and take off battery box cover.
- Hang out stirrup (3, Fig. 11).
- Take out battery and pull off plugs (1+2) from battery.

Advice:

Do not pull off any plug from card modul.

Reassembly:

- Connect plugs to new battery:
 - black cable: Negative Pole (1, Fig. 11)
 - red cable: Positive Pole (2) and put battery inside.
- Assemble stirrup (3) (bulge downward). Pay attention of correct cable routing (Fig. 11).
- Mount battery box cover by the 4 screws.
- Pull both Quick Releases outward and turn them to the „open“ position (Fig. 10).
- Position battery box onto luggage carrier struts.
- Push Quick Releases inwards and turn them to the „closed“ position (Fig. 10).
- Slide plug of battery cable in the slot of the battery box until it snaps in.

Advice:

Use only batteries as specified by SRAM.



CHARGING THE BATTERY

- Insert the plug of the charger into the socket of the battery box.
- Insert the charger into an electric mains socket.

The LED will glow red during charging, changing to green when the battery is fully recharged.

When not in use always withdraw the plugs from the socket and the battery box

Caution:

- **Recharge the battery at least every 3 months.**
- **The battery must only be charged in a temperature range of +5°C to +30°C.**
- **Only charge the battery in the operating position.**
- **Only use in dry internal areas.**
- **Do not use in rooms (garages) with an explosion risk.**
- **Do not dismantle the charging unit and battery box yourself.**
Incorrect assembly can lead to electric shock or fire.
- **The charging unit should not get into the hands of children.**
- **Charging should only be carried out in sufficiently well ventilated areas.**
- **When not in use always withdraw the plugs from the socket and the battery box (do not pull on the cables).**
- **Regularly check the cable and protect it from sharp edges. If it is damaged have it renewed immediately by a specialist workshop.**
- **Protect the unit from oil, grease, aggressive cleaning agents and paint thinners since they can destroy the housing.**
- **If it falls, from a bench for example, the unit must immediately be given a safety check by a specialist workshop. This is also necessary if contact pins become loose.**
- **The battery must never be burned. Risk of explosion!**
- **The battery must be disposed of according to the waste disposal regulations.**
- **Only ever use the right Sparc charging unit with the corresponding Sparc battery.**

STORING THE BATTERY

The battery box should be stored fully charged in a dry and cool place. Remove the plug of the battery cable from the box.

All batteries are shipped with an additional documentation about the last charging date within our SRAM facility. This documentation of battery charging also allows you to fill in the dates of additional charge actions that you would need to perform if the batteries stay in your warehouse over a longer period of time. You can identify the next necessary charge date at a glance (at least 3 months after last charge).

REMOTE CONTROL UNIT

Do not disassemble the remote control unit.

PROTECTION AGAINST OVERHEATING

At high thermal load all lights will start flashing prior to the eventually necessary protection shut-off of the drive unit. After cooling down the regular function of the system will be restored.

TROUBLESHOOTING

Problem	Cause	Remedy
Gear hub: Shifting difficulties	Damaged control cable	Replace control cable
	Incorrect gear setting	Adjust shifting system
	To much additional axle attachments between hub and axle nut	Beginning of axle thread must be visible in front of the axle nut
Pedals are carried forward when freewheeling	Bearings set too tight	Readjust bearings
	Loose lock nuts	Tighten lock nuts (15 – 20 Nm)
	Chain is overtensioned	Reduce chain tension
Electric system: Electric drive does not work	Remote control in position OFF	Switch to ECON or SPEED
	Remote control defect	Replace remote control
	Plugs not engaged	Slide all plugs completely in slots
	Cable defect	Replace defect cables
	Battery discharged	Charge battery
	Battery inside not connected	Connect battery inside box
	Battery defect	Replace battery
	Fuse blasted	Replace fuse (4, Fig. 9/11) in battery box: – 15 A for 16,8 V NiMH battery – 25 A for 12 V lead battery
	Electric drive defect	Replace electric drive
Electric drive emits unusual noise	Foreign body in electric drive	Take out foreign body
	Electric drive defect	Replace electric drive

BRAKE LEVER SRAM® BL 60

TECHNICAL DATA / ASSEMBLY REQUIREMENTS

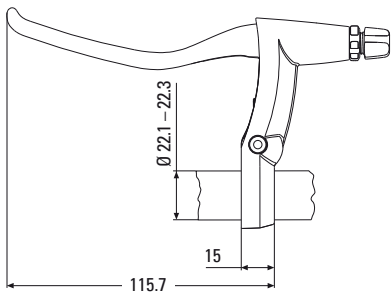

BRAKE LEVER

		SRAM BL 60	
Version		SRAM BL 60, left	SRAM BL 60, right
Mounting location		left side of handlebar	right side of handlebar
Clamping diameter		22.1 – 22.3 mm	←
Compatibility		Linear-Pull, Avid BB Disc	←
Ratio		2.32	←
Cable path		24 mm	←
Reach Adjust		Yes	←
Adjusting screw		Yes	←
Lever size		4-finger	4-finger
Weight		95 g	95 g
Housing		Cast aluminum	←
Lever		Aluminum, forged	←
Frame clamp		Aluminum	←
Finish		Mercury silver painted	←

CABLE AND CABLE HOUSING



Advice:

- Make sure that the cable housing length is sufficient to permit turning of the handlebar over its full range.
- » Also bear in mind the effect of adjustable handlebars and stems on the cable housing length.
- » Always use new, high-quality cables and compressionless cable housings with end caps.



Caution:

SRAM BL 60 brake levers are designed for use with Avid BB Disc Brakes and Linear-Pull compatible brakes. Do not use SRAM Brake Levers with conventional cantilever brakes (those with arms measuring less than 76 mm and utilizing a non-linear straddle cable). Use of SRAM Brake Levers with conventional cantilever brakesets, drum brakes or roller brakes will result in faulty braking performance.

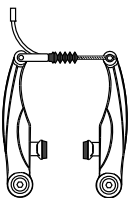

Designed for use with linear-pull brakes.

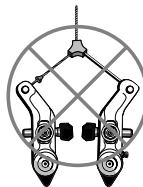

Do not use conventional cantilever brakes.

BRAKE LEVER SRAM® BL 60 ASSEMBLY / MAINTENANCE

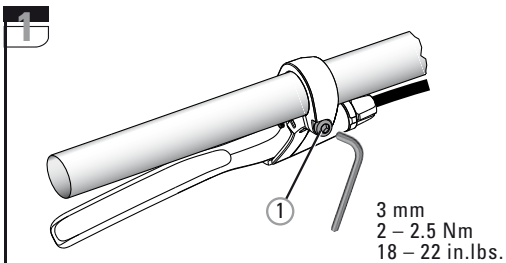

FITTING THE BRAKE LEVER

» Slide the brake lever onto the handlebar.

1 Tighten the clamping bolt.
3 mm Allen key, torque 2 – 2.5 Nm
(18 – 22 in.lbs.).

USE

Caution: Before riding, always check that all brake system components are functioning properly.

Advice: On your ride with your new bicycle, actuate the hand brake lever carefully to become familiar with the braking performance.

MAINTENANCE

Advice: Clean the brake lever using only water and mild soap.

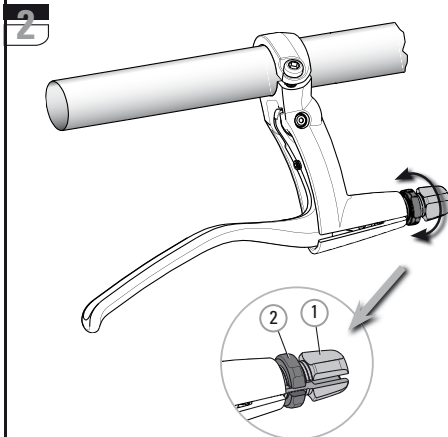

FITTING THE BRAKE CABLE

Caution: The SRAM BL 60 brake lever is only compatible with the following brakes: Avid BB Disc and Linear-Pull compatible brakes.

Advice: Make sure that the cable housing length is sufficient to permit turning of the handlebar over its full range.
» Also bear in mind the effect of adjustable handlebars and stems on the cable housing length.
» Always use new, high-quality cables and compressionless cable housings with end caps.

2 Turn the cable adjustment screw (1) and the counter nut (2) so that the cable slot is aligned with the slot on the bottom of the brake lever housing.

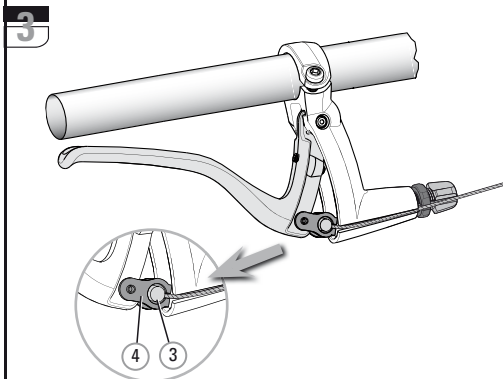

3 Pull the brake lever to the handlebar and guide the inner cable into the housing.
Hook the nipple (3) of the inner cable into the recess (4) in the brake lever.

» Follow the brake manufacturer's instructions when fitting the brake cable and adjusting the brakes.

Caution: Check that the brake is operating in a correct and trouble-free manner.

Reach adjust of the hand brake lever: so that you can operate the brake lever on the shifter comfortably, set the reach to match your hand size.

4 Use a 2 mm Allen key to set the distance between the brake lever and the handlebar.

Caution: Every time you adjust the reach, check and correct the brake cable tension to ensure good brake performance.

Advice: Read and observe the operating manual and technical documentation of the brake manufacturer.

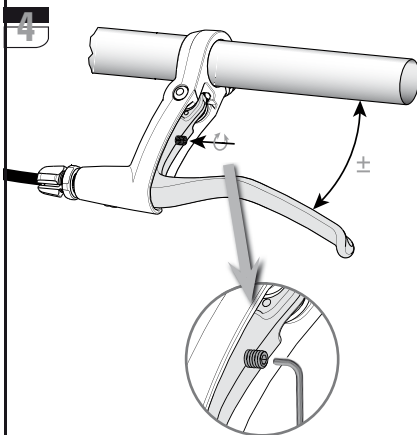

i-LIGHT™ - DYNAMO HUBS · D7-SERIES / D3-SERIES

TECHNICAL DATA / ASSEMBLY REQUIREMENTS

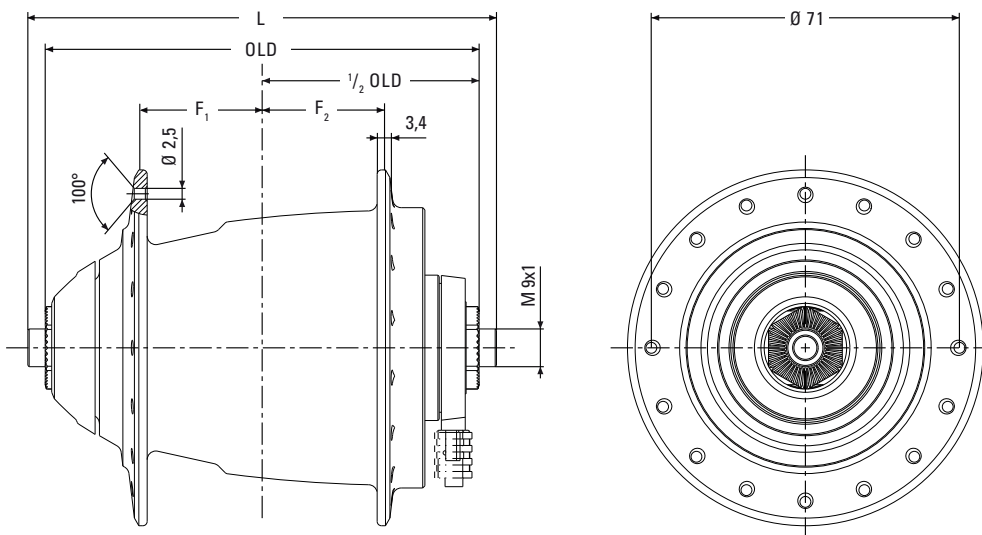

Caution: The dynamo hub generates an extremely high voltage. Never touch the connection terminal of the dynamo hub while riding or while the wheel is spinning. This may cause an electric shock.

D 7 2 4	Model	D724-N		D730-N		D724-D		D730-D		
	Version	Standard		→		Disc Brake compat. / 6 holes				
	Output	2.4 Watt		3.0 Watt		2.4 Watt		3.0 Watt		
	Voltage	6 V		←		6 V		←		
	Wheel ø	400 – 720 mm / 16" – 28"		←		400 – 720 mm / 16" – 28"		←		
	Over Locknut Dim., OLD	100 mm		←		100 mm		←		
	Axle	Length, L	140 mm	108 mm	140 mm	108 mm	140 mm	108 mm	140 mm	108 mm
		Type	Solid	Hollow ¹	Solid	Hollow ¹	Solid	Hollow ¹	Solid	Hollow ¹
		Material	Steel		←		Steel		←	
		Ends Diameter	M 9 x1	–	M 9 x1	–	M 9 x1	–	M 9 x1	–
Spoke	Holes	36 / 32		←		36 / 32		←		
	Hole Diameter	2.5 mm		←		2.5 mm		←		
	Hole Reference ø	71 mm		←		71 mm		←		
	Flange Width	3.4 mm		←		3.4 mm		←		
	Flange Distance, F₁/F₂	F ₁ = 28 mm / F ₂ = 28 mm		←		F ₁ = 18 mm / F ₂ = 31 mm		←		
	Offset	0 mm		←		6.5 mm		←		
	Bearing	Cartridge		←		Cartridge		←		
Sealing	Double Sealed		←		Double Sealed		←			
Homologation	KBA homologation for versions with 3.0 Watt (KBA = Kraftfahrtbundesamt Germany)									
Efficiency	70% at 15 km/h		←		70% at 15 km/h		←			
Weight	557 g	525 g	N/A	580 g	557 g	525 g	N/A	580 g		
Finish Hub Shell	Aluminum, silver or black anodized									

¹ Caution: Quick release braking load min. 10000 N (2250 lbs.)!

i-LIGHT™ – DYNAMO HUBS · D7-SERIES / D3-SERIES

TECHNICAL DATA / ASSEMBLY REQUIREMENTS



D
3
2
4

D
3
3
0

	D324-N		D330-N		D324-N-74		D330-N-74		
Model	D324-N		D330-N		D324-N-74		D330-N-74		
Version	Standard		←		Standard		←		
Output	2.4 Watt		3.0 Watt		2.4 Watt		3.0 Watt		
Voltage	6 V		←		6 V		←		
Wheel ø	400 – 720 mm / 16" – 28"		←		300 – 720 mm / 12" – 28"		←		
Over Locknut Dim., OLD	100 mm		←		74 mm		←		
Axle	Length, L	140 mm	108 mm	140 mm	108 mm	114 mm	82 mm	114 mm	82 mm
	Type	Solid	Hollow ¹	Solid	Hollow ¹	Solid	Hollow ¹	Solid	Hollow ¹
	Material	Steel		←		Steel		←	
	Ends Diameter	M 9 x1	–	M 9 x1	–	M 9 x1	–	M 9 x1	–
Holes	36		←		20		←		
Hole Diameter	2.5 mm		←		2.5 mm		←		
Spoke	Hole Reference ø	71 mm		←		71 mm		←	
	Flange Width	3.4 mm		←		3.4 mm		←	
	Flange Distance, F₁/F₂	F ₁ = 28 mm / F ₂ = 28 mm		←		F ₁ = 20.5 mm / F ₂ = 20.5 mm		←	
	Offset	6.5 mm		←		0 mm		←	
Bearing	Cartridge		←		Cartridge		←		
Sealing	Double Sealed		←		Double Sealed		←		
Homologation	KBA homologation for versions with 3.0 Watt (KBA = Kraftfahrtbundesamt Germany)								
Efficiency	65% at 15 km/h		←		65% at 15 km/h		←		
Weight	556 g	519 g	607 g	575 g	500 g	N/A	N/A	N/A	
Finish Hub Shell	Alum., silver or black painted				Aluminum, silver painted				

¹ Caution: Quick release braking load min. 10000 N (2250 lbs.)!

1

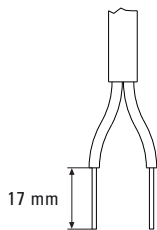

CABLE REQUIREMENTS

Recommended wire specifications:
 Inner wire size AWG 22 / Diameter approx. 0.8 mm.
 Wire insulation: 1.8 – 2 mm.
 Remove insulation by 17 mm (Fig. 1).

Advice:
 Cables with a minimum cross-section of 0.4 mm² and a cable resistance of ≤ 0.045 Ω/m shall be used for the electrical connection of lighting equipment and for electrical supply systems.

OVERVOLTAGE PROTECTION

Caution:
 To protect the bulbs against overvoltage, e.g. if one lamp breaks down, the lighting system must be designed so that at a load of 60 Ω are not exceeded.

If your system doesn't have an overvoltage protection we recommend the SRAM overvoltage protection cable (Part # 92.2015.003.000) (Fig. 2).

2

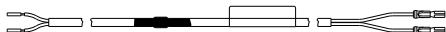

i-LIGHT™ - DYNAMO HUBS · D7-SERIES / D3-SERIES ASSEMBLY

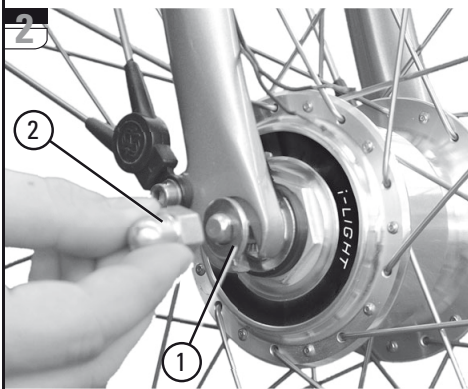
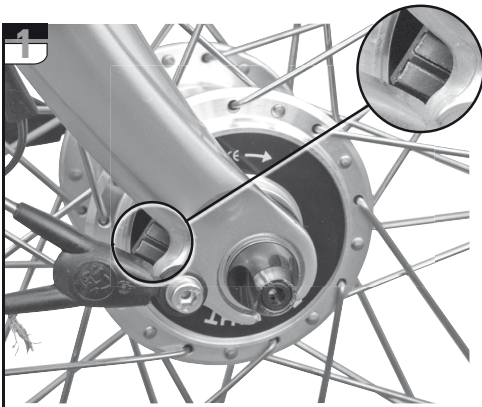

ASSEMBLING THE HUB

Caution:
The dropouts of the fork must be parallel.

- Lacing the hub as normal.

- Hub version for Disc Brake:
Advice:
Read and observe the corresponding technical documentation for assembling the disc of the disc brake.

Caution:
Plane faces and threaded holes of the hub must be clean and free from oily and greasy substances.

- Place the front wheel into the front fork.

Advice:
The connection terminal of the dynamo hub should be on the right side viewed from behind the rear of the bicycle. The connection terminal should tend upwards or backwards.

Fastening wheel / solid axle:

Place one retaining washer (1) on each axle end.

Fit the axle nuts (2).
– Tighten the axle nuts while alternating between sides, to course that the dynamo hub connection terminal do not turn away from the correct orientation.
– The recommended axle nut tightening torque is 20 Nm (177 in.lbs.).

Caution:
If the axle nuts are screwed on too tight, or if one or the other is screwed tighter or looser than the other, the hub axle may be forced to turn. Making the axle nuts looser or too tight, this could permanently damage the dynamo hub.

Fastening wheel / quick release:

- Only use quick release devices with the correct length.

- Position quick release opposite to the brake (Disc Brake version).

- Turn release lever outwards until it is at least at a right angle to the bike (position "OPEN").

- Tighten adjusting nut on the end of the skewer as much as possible by hand.

Turn release lever to the "closed" position (the word "CLOSE" is visible from the outside).

- After closure, the release lever should be parallel to the fork. If the release lever can be closed relatively easily, the tension force is inadequate. In this case, open release lever again, tighten adjusting nut slightly and close release lever again.

- If considerable force is required to close the lever, open the lever again, undo the adjusting nut slightly and close lever again.

Caution:
Do not tighten the wheel by turning the release lever clockwise.

- Only use hand force.
- By incorrectly mounting the skewer or the wheel in the dropout, or by wrongly adjusting the closing force, the wheel may come loose and fall off during the ride. This may lead to severe rider injury or death.

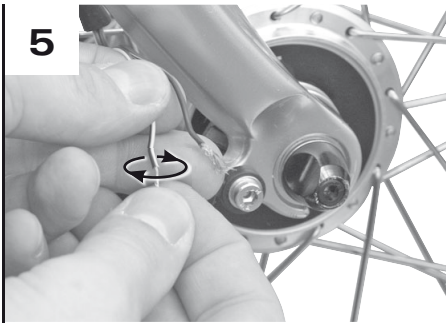

5

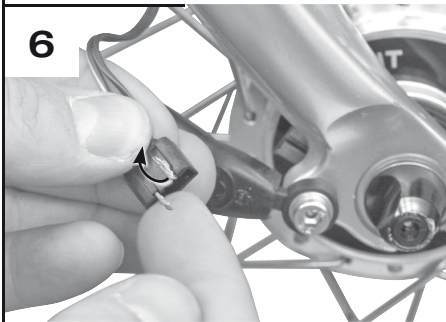

6

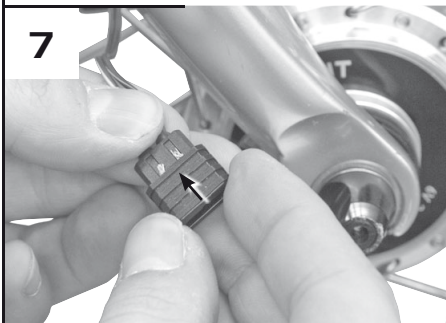

7

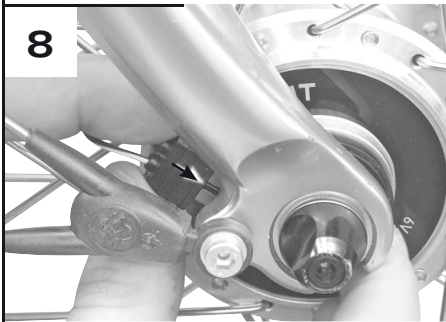

8

CONNECTING THE CABLES

- Strip the insulation off of the wire approximately 17 mm.

5 Twist the cable wires before connecting.

6 Stick the cables through the two holes of the inner connecting piece. Bend the cable wires and run them along the grooves.

7 Push the inner piece with cable wires into the outer piece.

Advice: When doing this, ensure that the flattened corner of the inner piece matches the corresponding shape in the outer piece.

8 Connect the cable with the dynamo hub. Push the connecting piece onto the connection terminal of the dynamo hub.

Caution: Make sure, that it is securely connected before using the dynamo hub.

Check: Rotate the front wheel and check the lamp illumination.

Caution: The dynamo hub generates an extremely high voltage. Never touch the connection terminal of the dynamo hub while riding or while the wheel is spinning. This may cause an electric shock.

Caution: Before setting out on any ride, always check the correct and trouble-free operation of the dynamo hub.

MAINTENANCE

- Do not disassemble the internal hub mechanism.

- The hub is provided with permanent lubrication.

Advice: Do not apply any lubricant to the inside of the hub, otherwise the grease will come out and it may cause problems with conductivity.

Caution: If the axle nuts are screwed on too tight, or if one or the other is screwed tighter or looser than the other, the hub axle may be forced to turn. Making the axle nuts looser or too tight, this could permanently damage the dynamo hub.

POWER CHAIN™

TECHNICAL DATA / ASSEMBLY REQUIREMENTS

POWER CHAIN

	PC 1 Saltshaker	PC 1 Ni	PC 1		
Application	Gear Hubs	Gear Hubs	Gear Hubs		
Max. No. of sprockets	1	1	1		
Compatibility Front	Single	Single	Single		
Compatibility Rear	Single	Single	Single		
Dimension	$\frac{1}{2}'' \times \frac{1}{8}''$	$\frac{1}{2}'' \times \frac{1}{8}''$	$\frac{1}{2}'' \times \frac{1}{8}''$		
Length	7.8 mm	7.8 mm	8,98 mm		
Riveting	Step	Step	V shape		
Chrome Hardened	No	No	No		
Push Power	800 N	800 N	800 N		
Min. Tensile Strength	8000 N	8000 N	8000 N		
Weight (114 links)	330 g	330 g	356 g		
External Pin Plate	Light Grey	Silver / Nickel Plated	Brown		
Internal Pin Plate	Light Grey	Silver / Nickel Plated	Brown		
Connecting Method	Snap Lock or Pin	Snap Lock, 3pcs Connection Link or Pin			

POWER CHAIN

	PC 10 Saltshaker	PC 10			
Application	Gear Hubs / MTB	Gear Hubs / MTB			
Max. No. of sprockets	max. 7	max. 7			
Compatibility Front	Single / HG®	Single / HG®			
Compatibility Rear	Single / HG®	Single / HG®			
Dimension	$\frac{1}{2}'' \times \frac{3}{32}''$	$\frac{1}{2}'' \times \frac{3}{32}''$			
Length	6.97 mm	6.97 mm			
Riveting	Step	Step			
Chrome Hardened	No	No			
Push Power	1000 N	1000 N			
Min. Tensile Strength	9000 N	9000 N			
Weight (114 links)	300 g	300 g			
External Pin Plate	Light Grey	Brown			
Internal Pin Plate	Light Grey	Brown			
Connecting Method	Power Link SS1 or Pin	Power Link 7SPD or Pin			

POWER CHAIN™

TECHNICAL DATA / ASSEMBLY REQUIREMENTS



POWER CHAIN

	PC 991	PC 991 Hollow Pin	PC 991 Cross Step	PC 971	PC 951
Application	MTB / Road	MTB / Road	MTB / Road	MTB / Road	MTB / Road
Max. No. of sprockets	9 only	9 only	9 only	9 only	9 only
Compatibility Front	Truvativ® / HG® / EXA-Drive®	Truvativ® / HG® / EXA-Drive®	Truvativ® / HG® / EXA-Drive®	Truvativ® / HG® / EXA-Drive®	Truvativ® / HG® / EXA-Drive®
Compatibility Rear	HG® / PG / EXA-Drive®	HG® / PG / EXA-Drive®	HG® / PG / EXA-Drive®	HG® / PG / EXA-Drive®	HG® / PG / EXA-Drive®
Dimension	$\frac{1}{2}'' \times \frac{11}{128}''$	$\frac{1}{2}'' \times \frac{11}{128}''$	$\frac{1}{2}'' \times \frac{11}{128}''$	$\frac{1}{2}'' \times \frac{11}{128}''$	$\frac{1}{2}'' \times \frac{11}{128}''$
Length	6.65 mm	6.35 mm	6.65 mm	6.65 mm	6.65 mm
Riveting	Step	Cylindrical	Cross Step	Step	Step
Chrome Hardened	Yes	Yes	Yes	Yes	Yes
Push Power	2000 N	2000 N	2500 N	2000 N	2000 N
Min. Tensile Strength	9000 N	9000 N	9000 N	9000 N	9000 N
Weight (114 links)	297 g	276 g	297 g	297 g	297 g
External Pin Plate	Silver / Nickel Plated	Silver / Nickel Plated	Silver / Nickel Plated	Silver / Nickel Plated	Grey / Polished
Internal Pin Plate	Silver / Nickel Plated	Silver / Nickel Plated	Silver / Nickel Plated	Grey / Polished	Grey / Polished
Connecting Method ¹	Power Link 9spd or Pin	Power Link 9spd only	Power Link 9spd only	Power Link 9spd or Pin	Power Link 9spd or Pin

¹ **Caution:** Hollow Pin and Cross Step chains connecting method: with Power Link only (no pin)!

POWER CHAIN

	PC 890	PC 870	PC 850	PC 830 Saltshaker	PC 830
Application	MTB / Road	MTB / Road	MTB / Road	MTB / Road	MTB / Road
Max. No. of sprockets	max. 8	max. 8	max. 8	max. 8	max. 8
Compatibility Front	HG® / IG® / PG / EXA-Drive®	HG® / IG® / PG / EXA-Drive®	HG® / IG® / PG / EXA-Drive®	HG® / IG® / PG / EXA-Drive®	HG® / IG® / PG / EXA-Drive®
Compatibility Rear	HG® / IG® / PGII / EXA-Drive®	HG® / IG® / PGII / EXA-Drive®	HG® / IG® / PGII / EXA-Drive®	HG® / IG® / PGII / EXA-Drive®	HG® / IG® / PGII / EXA-Drive®
Dimension	$\frac{1}{2}'' \times \frac{3}{32}''$	$\frac{1}{2}'' \times \frac{3}{32}''$	$\frac{1}{2}'' \times \frac{3}{32}''$	$\frac{1}{2}'' \times \frac{3}{32}''$	$\frac{1}{2}'' \times \frac{3}{32}''$
Length	6,92 mm	6,92 mm	6,92 mm	6,92 mm	6,92 mm
Riveting	Step	Step	Step	Step	Step
Chrome Hardened	Yes	Yes	Yes	No	No
Push Power	2000 N	2000 N	2000 N	1300 N	1500 N
Min. Tensile Strength	9000 N	9000 N	9000 N	9000 N	9000 N
Weight (114 links)	313 g	313 g	313 g	313 g	313 g
External Pin Plate	Silver / Nickel Plated	Silver / Nickel Plated	Grey / Polished	Light Grey	Grey / Polished
Internal Pin Plate	Silver / Nickel Plated	Grey / Polished	Grey / Polished	Light Grey	Grey / Polished
Connecting Method	Power Link 8SPD only	Power Link 8SPD or Pin	Power Link 8SPD or Pin	Power Link SS2 or Pin	Power Link 8SPD or Pin

POWER CHAIN™ ASSEMBLY

1

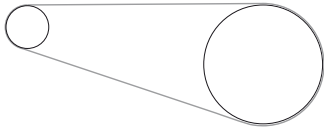

2

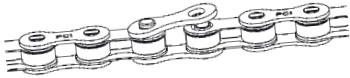

3

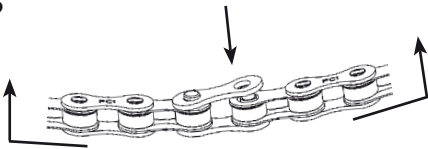

4

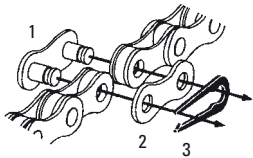

5

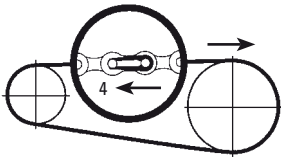

6

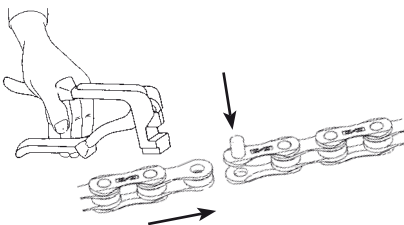

PC 1 (1/2" X 1/8")

Chain length:

(A chain tool will be required to shorten the chain.)

- Replacing a worn chain:
Measure the worn chain and shorten the new to the same length.
- Initial assembly:
Shorten the chain to the length specified by the drivetrain manufacturer.
SRAM components:
Place the chain over front chainwheel and rear sprocket (**Fig. 1**). For rear suspension frame, position the rear suspension for the greatest chain length required.

Closing chain with Snap Lock:

- Fit the shortened chain, bring the ends together and connect with the Snap Lock. Place the outer plate on one pin (**Fig. 2**).
- Gently flex the chain until the outside connector plate snaps into position over the second pin (**Fig. 3**).

Caution:

- **Make sure plate is fully seated in the pin channel and plates are parallel to each other.**
- **If movement of the connector plate is noticed a new Snap Lock must be used.**
- **Snap Lock is for one-time use only!**
- **Always use a new Snap Lock when fitting a new chain.**
- **Use Snap Lock only with SRAM chains!**
- **Failure to shorten the chain properly or to lock it exactly into place may cause damage to the chain and eventually total chain failure, material damage or the rider to fall off his bicycle resulting in injury.**
- **Worn sprockets should also be replaced when a new chain is fitted.**

Closing chain with 3pcs Connection Link:

- Fit the shortened chain, bring the two ends together and connect with the chain lock. The chain lock consists of an outer plate with pins (**1, Fig. 4**), an outer plate (**2**) and a retaining spring (**3**).
- Insert outer plate with pins (**1**) into the chain ends, attach outer plate (**2**) and press chain lock together (**1+2**).
- Attach retaining spring (**3**) with the closed end of the retaining ring pointing in the direction of chain travel (**Fig. 4**).
- Slide retaining spring in the direction of arrow (**4, Fig. 5**) to engage it in the grooves in the pins.

Closing standard version with clamping pin:

Fit chain, bring the two ends together and press pin (**Fig. 6**) through with assembly tool.

The pin must extend by the same amount at both outer plates. It must be possible to move the connecting link slightly.



7

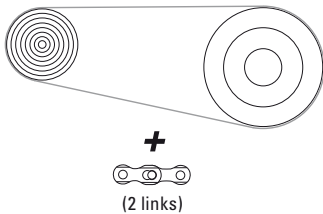

**PC 991 / PC 971 / PC 951 /
PC 890 / PC 870 / PC 850 /
PC 830 / PC 10**
(1/2" X 3/32" AND 1/2" X 11/128")

Chain length:

(A chain tool will be required to shorten the chain.)

- Replacing a worn chain: Measure the worn chain and shorten the new to the same length.

- Initial assembly: Shorten the chain to the length specified by the derailleur manufacturer.

SRAM derailleurs:

- Place the chain over largest front chainwheel and largest rear sprocket (Fig. 7). For rear suspension frame, position the rear suspension for the greatest chain length required.
- Add 2 links or 1 link + Power Link (Fig. 7).
- DualDrive II hub equipped bicycles: Add 4 links or 3 links + Power Link hinzufügen.

8

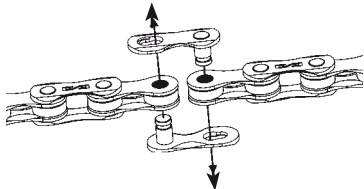

9

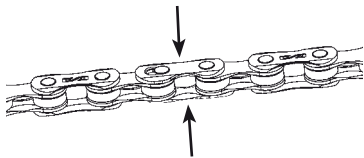

Closing chain with Power Link:

Caution:

- **Use Power Link only with SRAM chains!**
- **Use only Power Link to close Hollow Pin chains and Cross Step chains (no Pin)!**
- **Use only as specified, to avoid material damage or the rider to fall off his bicycle resulting in injury:**

Power Link 9SPD (gold coloured):
for PC 991 Hollow Pin, PC 991 Cross Step,
PC 991, PC 971, PC 951

Power Link 8SPD (silver coloured):
for PC 890, PC 870, PC 850, PC 830

Power Link SS2 (light grey coloured):
for PC 830 Saltshaker

Power Link SS1 (light grey coloured):
for PC 10 Saltshaker

Power Link 7SPD (grey coloured):
for PC 10

Power Link SS1 (light grey coloured):
for PC 10 Saltshaker

Power Link 7SPD (grey coloured):
for PC 10

Power Link 7SPD (grey coloured):
for PC 10

Power Link 7SPD (grey coloured):
for PC 10

Closing:

- Fit chain, bring the ends together and insert both halves of the Power Link into the chain ends. (Fig. 8)
- Press both halves of the Power Link together (Fig. 9) and lock in place by pulling the chain apart. (Fig. 10)

Opening:

Press both plates of the Power Link together (Fig. 9) while sliding the chain ends together (unlock). Remove the two halves of the link from the chain ends.

Caution:

- **Always use a new Power Link when fitting a new chain.**
- **Failure to shorten the chain properly or to lock it exactly into place may cause damage to the chain and eventually total chain failure, material damage or the rider to fall off his bicycle resulting in injury.**
- **Worn sprockets should also be replaced when a new chain is fitted.**

Closing standard version with clamping pin:

Fit chain, bring the two ends together and press pin through with assembly tool (Fig. 6). The pin must extend by the same amount at both outer plates. It must be possible to move the connecting link slightly.

10

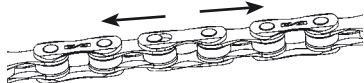

MAINTENANCE / CARE

- Clean dirty chains before oiling. Do not use any acidic agents. Let cleaner set for only a few minutes and rinse with water. Do not oil chain until completely dry.
- Regular lubrication will extend the chain's service life. Apply oil to the chain links rollers and allow to work in.

www.sram.com

world headquarters

SRAM LLC
1333 n. kingsbury st., 4th fl
chicago, il 60622
phone +1-312-664-8800
fax +1-312-664-8826

european headquarters

SRAM europe
basicweg 12-d
3821 br amersfoort
the netherlands
phone +31-33-450-6060
fax +31-33-457-0200

asian headquarters

SRAM taiwan
no. 1598-8 chung shan rd
shen kang hsiang, taichung
county 429 taiwan r.o.c.
phone +886-4-2561-3678
fax +886-4-2561-3686